

High Performance Centres for Turning and Grinding

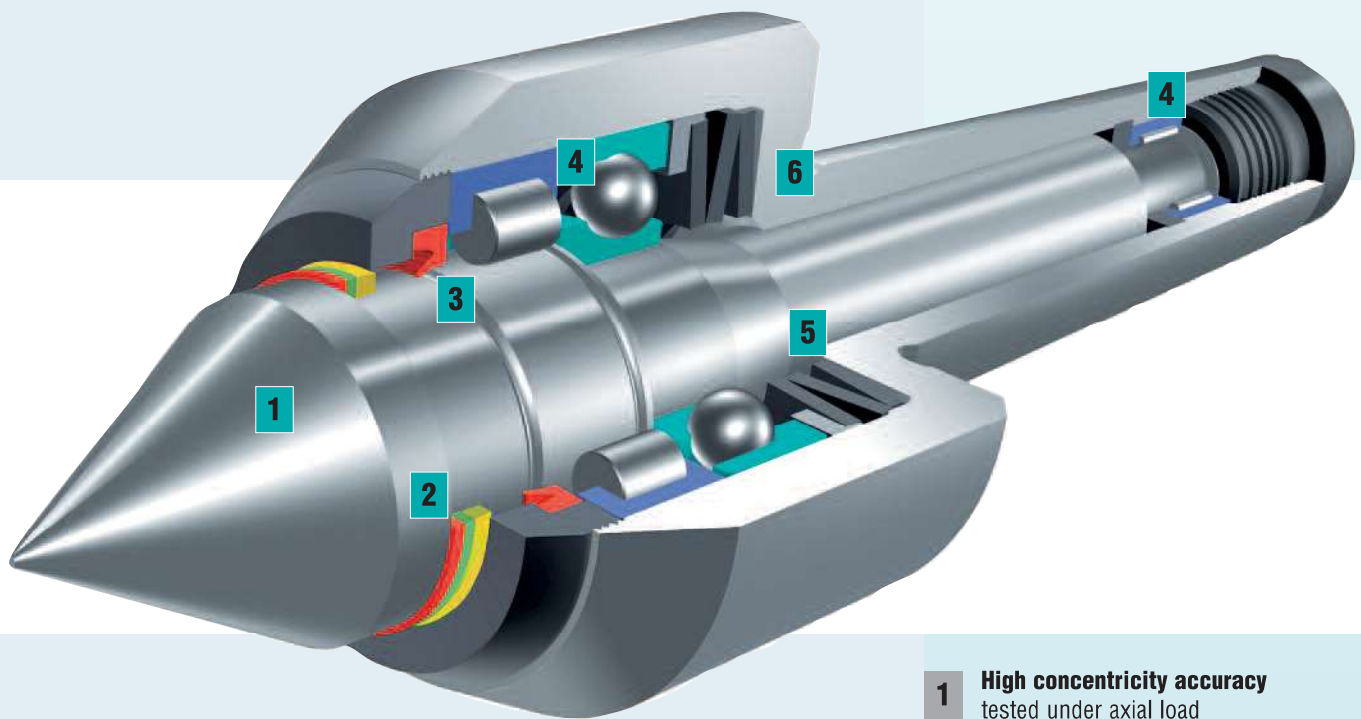

LR Series – simultaneous clamping and regulation

The spring loaded centrepoint with colour rings for pressure indication allows simple adjustment and reading of the axial pressure.

The spring loading compensates for workpiece thermal expansion and variation of workpiece length. LR series centres are essential for operations using face drivers or machine tools without pressure indication.

The ideal arrangement of the high precision roller bearings prove the strength of the LR types for higher speed.

- 1 High concentricity accuracy**
tested under axial load
guaranteed by test report
- 2 Spring loaded centrepoint**
of through-hardened alloy wear
resistant tool steel. With coloured
rings for pressure indication
- 3 Seal ring**
protects the bearings from dirt and
coolant
- 4 Precision bearings**
with precision ground bearing seats
of housing and on the centre spindle.
The bearing seats are matched to the
bearings. Maintenance-free
permanent lubrication
- 5 Spring loading**
- 6 Housing**
of high tensile tool steel.
Housing head and shank are case
hardened for protection from
damage

Produced according to BRUCKNER WORKS STANDARD (page 8)

Types LRS, LRSG

Centrepoint 60° spring loaded
Pressure indication by coloured rings

Runout

Type LRS max. 0.005 mm
 Type LRSG max. 0.003 mm
 with test report

Application

Turning, CNC turning with multi-spindle machines or CNC lathes with twin tool turrets.
 As a tailstock centre when using face drivers

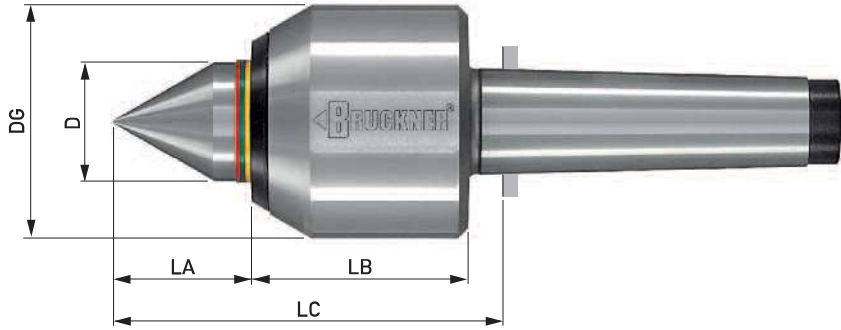

Type LRS	ID.No.	700S 055003	700S 068004	700S 092005	700S 127006
Type LRSG	ID.No.	701S 055003	701S 068004	701S 092005	701S 127006
Morse taper		3	4	5	6
D		25	35	50	70
DG		55	68	92	127
LA		28	40	57	74
LB		51	63	82	109
LC		84	108	145	190
Max. workpiece weight max daN*		420	1200	2000	4400
Spring travel		2.7	4.2	5.4	8.4
r.p.m. max.*		5000	4000	3500	2300
radial/axial load graph		RR1/AR1	RR2/AR2	RR3/AR3	RR4/AR4
Axial force per colour ring		page 28			

Available with draw-off thread and draw-off nut (design A)

*observe the load graphs

Radial and axial loads for a bearing life of 2,000 operating hours (calculation example on page 11)

Radial – Types LRS, LRSG

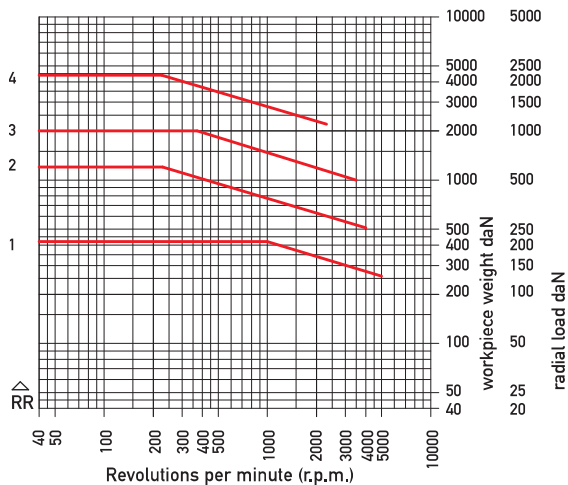

Axial – Types LRS, LRSG

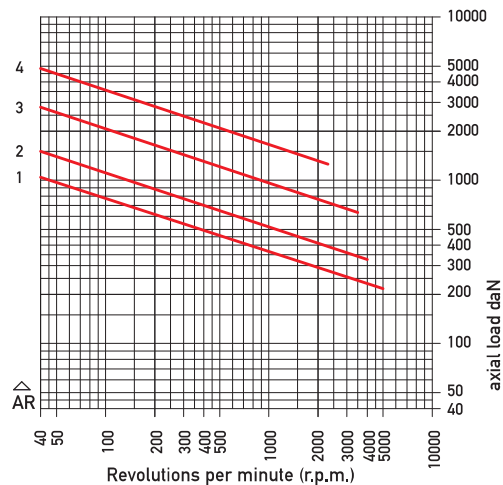

Type LRV

Centrepoint 60°/40° extended spring loaded with pressure indication by coloured rings

Runout

Max. 0.005 mm with test report
Max. 0.003 mm high-precision design on request

Application

Turning, CNC turning.
With multi-spindle machines or CNC lathes with twin tool turrets.
As a tailstock centre when using face drivers. The extended slim centrepoint allows improved access for cutting tools

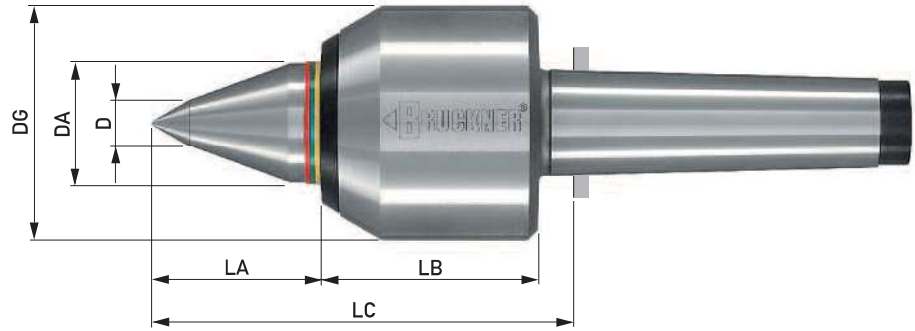

Type LRV	ID.No.	700V 055003	700V 068004	700V 092005
Morse taper		3	4	5
DA		25	35	50
D		12	14	18
DG		55	68	92
LA		37	49	69
LB		51	63	82
LC		93	117	157
Workpiece weight max. daN*		320	900	1400
Spring travel		2.7	4.2	5.4
r.p.m. max.*		5000	4000	3500
radial/axial load graph		RF1/AF1	RF2/AF2	RF3/AF3
Axial force per colour ring		page 28		

Available with draw-off thread and draw-off nut (design A)

*observe the load graphs

Radial and axial loads for a bearing life of 2,000 operating hours (calculation example on page 11)

Radial – Type LRV

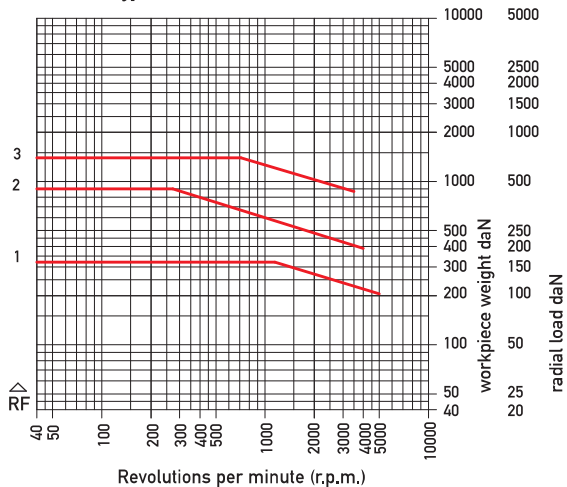

Axial – Type LRV

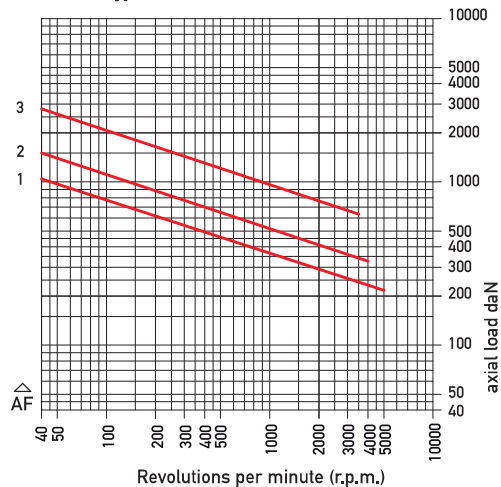

Type LRE

Spring loaded centrepoint with 1:7.5 internal taper for interchangeable inserts. Pressure indication by coloured rings

Runout

Max. 0.005 mm with test report
Max. 0.003 mm high-precision design on request

Application

Turning, CNC turning with multi-spindle machines or CNC lathes with twin tool turrets.
As a tailstock centre when using face drivers. The extended slim centrepoint allows improved access for cutting tools.

Advantages

As the centrepoint wears only the insert has to be changed and once again the high performance centre is ready for use. Flexibility in application is made possible by a choice of eight different insert styles (page 33).

Depending on the style the insert can be removed by its draw-off thread and draw-off nut or with spanners applied to the spanner flats.

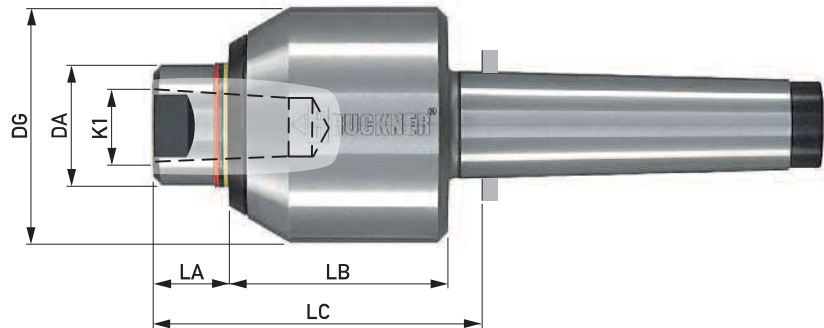

Type LRE	ID.No.	700E 055003	700E 068004	700E 092005
Morse taper		3	4	5
DA		25	35	50
K1		15	22	28
DG		55	68	92
LA		15	21	28
LB		51	63	82
LC		71	89	116
Spring travel		2.7	4.2	5.4
r.p.m. max. 1/min		5000	4000	3500
Suitable inserts		484..	487..	485..
Load	The radial load of type LRE is restricted by the interchangeable (page 33)			
Axial force per coloured ring	page 28			

Available with draw-off thread and draw-off nut (design A, page 28)
MT2 on request (700E 045002)

Interchangeable inserts

taper 1:7.5, in gauge accuracy

Form AO, 60°
draw-off thread

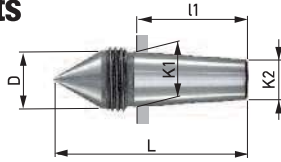

Form ASL, 60°
slim, extended
draw-off thread

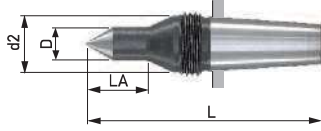

Form AKOP, 60°/40°
extended
draw-off thread

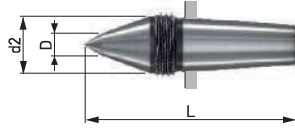

Form A, 60°
for hollow parts
spanner flat

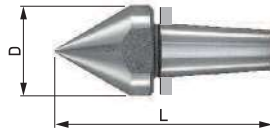

Form B, centre 60°
for centreless workpieces,
draw-off thread

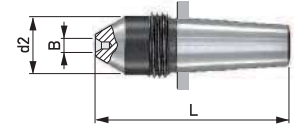

Form C, centre 60°
for centreless workpieces,
external angle 60° for hollow
parts, spanner flat

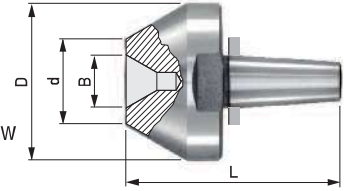

Form D, centre 60°
for centreless workpieces,
spanner flat

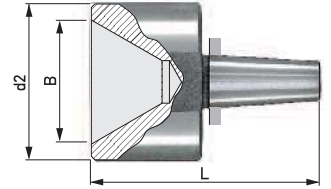

Form AOHM, 60°
with carbide insert
draw-off thread

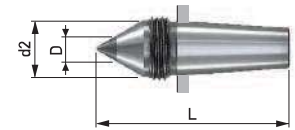

Basic body Type: LRE	Centering inserts	radial load max. daN	inserts dimensions						thread SW	taper dimensions		
			taper 1:7.5							K1	K2	l1
Bestell-Nr.	Bestell-Nr.		D	d2	B	d	L	LA				
700E 055003	484AO	160	15.7				53		M 18x1.5	15	11	30
	484ASL	100	9	15.7			65	17	M 18x1.5			
	484AKOP	160	6	15.7			58		M 18x1.5			
	484A	160	25				60		SW22			
	484B	110	15.7		4x2		53		M 18x1.5			
	484C	160	44		15x5	24	60		SW41			
	484D	160	44		35x12		64		SW41			
	484AOHM	60	7	15.7			53		M 18x1.5			
700E 068004	487AO	300	21.6				74		M 24x1.5	22	16.4	42
	487ASL	100	9	21.6			86	17	M 24x1.5			
	487AKOP	300	8	21.6			80		M 24x1.5			
	487A	300	32				82		SW27			
	487B	240	21.6		5x2.5		74		M 24x1.5			
	487C	300	55		20x6	30	82		SW50			
	487D	300	55		45x15		85		SW50			
	487AOHM	200	11	21.6			74		M 24x1.5			
700E 092005	485AO	500	27.7				93		M 30x1.5	28	21	52.5
	485ASL	180	13	27.7			110	27	M 30x1.5			
	485AKOP	500	8	27.7			105		M 30x1.5			
	485A	500	45				105		SW41			
	485B	500	27.7		7x3		93		M 30x1.5			
	485C	500	65		25x6	35	105		SW55			
	485D	500	65		55x20		105		SW55			
	485AOHM	500	18	27.7			93		M 30x1.5			

ID.No.	content
P 10	100 g

Installation paste

Makes insert change easier.
Apply thinly and evenly to the insert taper.

for hard turning



for vertical turning machines



with internal taper 1:7.5 for interchangeable inserts



with spring and coloured pressure indication



High Performance Bullnose Live Centres Special Designs

for mounting chucks



pointed design



with carbide cap and flange mounting



with carbide triple contact pads





from small to large



HSK40



with sealing air connection



ABS50



large centrepoint



Captor4



carbide spherical centre



live collet chuck



Karl Bruckner GmbH
Precision Tool Manufactures

P.O. Box 3146
D-71373 Weinstadt
Bruckwiesenstraße 13
D-71384 Weinstadt-Großheppach

Phone +49 (0) 7151 9671-0
Fax +49 (0) 7151 9671-23
info@karlbruckner.de
www.karlbruckner.de

> ...also in our programm

HS Face Drivers
with hydraulic compensation



SM Face Drivers
with mechanical compensation



Work Drivers

