

Universal Self-Centering Vice

UVP – Pneumatic drive

Pneumatically actuated 2-jaw self-centering vise in compact design with a high clamping force. The vises are available with standard stroke, long stroke and fixed jaw.

Advantages

- Precise wedge-hook mechanism allows machining accuracy
- High force drive for secure clamping
- Extended clamping range with long jaw guidance
- Optimum jaw guides (hardened, sturdy, low-backlash) allow high clamping forces at a long service life
- Low profile: Maximum use of the machine room and excellent rigidity of the system
- Lean outer contour for optimal accessibility of the machine spindle to the workpiece
- Cubic design: ideal for 6-sided machining
- Optimized lubrication system for consistently high clamping forces
- Base jaws with tongue and groove or fine serration as standard for high flexibility of top jaws
- All functional parts are hardened and ground to ensure a long service life

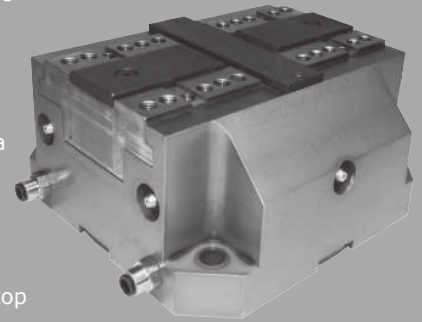

SPECIFICATIONS

Model	Stroke Per Jaw	Closing Force Per Jaw @ Max pressure	Total Closing Force @ Max pressure	Max Pressure	Repeat accuracy vise	Max Jaw height	Fluid consumption per double stroke	Closing/opening time	Weight
UVP 100	2 mm 0.08 in	9000 N 2023.2 lb	18000 N 4046.4 lb	9 bar 130.5 psi	± 0.01 mm ±0.0004 in	60 mm 2.36 in	1000 mm 61.00 in	0.2 s	5 Kg 11.00 lb
UVP 100 X	6 mm 0.24 in	3000 N 674.4 lb	6000 N 1348.8 lb	9 bar 130.5 psi	± 0.01 mm ±0.0004 in	150 mm 5.91 in	1000 mm 61.00 in	0.2 s	5 Kg 11.00 lb
UVP 160	3 mm 0.12 in	22500 N 5058 lb	45000 N 10116.0 lb	9 bar 130.5 psi	± 0.01 mm ±0.0004 in	60 mm 2.36 in	3400 mm 207.40 in	0.4 s	14 Kg 30.80 lb
UVP 160 X	8 mm 0.31 in	8400 N 1888.32 lb	16800 N 3777 lb	9 bar 130.5 psi	± 0.01 mm ±0.0004 in	200 mm 7.87 in	3400 mm 207.40 in	0.4 s	14 Kg 30.80 lb

* Recommended workpiece weight is calculated for force-fit clamping with a coefficient of static friction of 0.15 and a safety factor of 3 against workpiece slippage.

SECTIONAL DIAGRAM

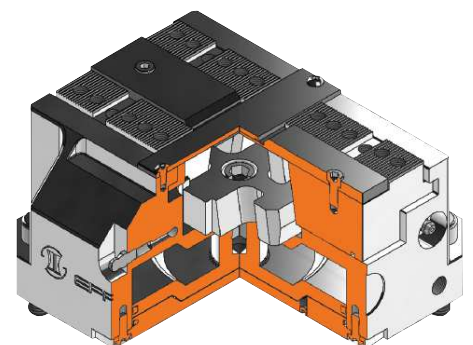
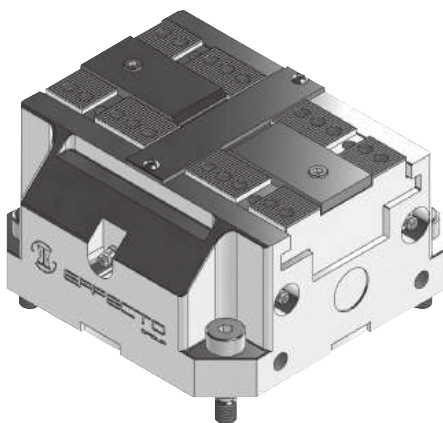

PRODUCT INFORMATION

UVP – Pneumatic drive

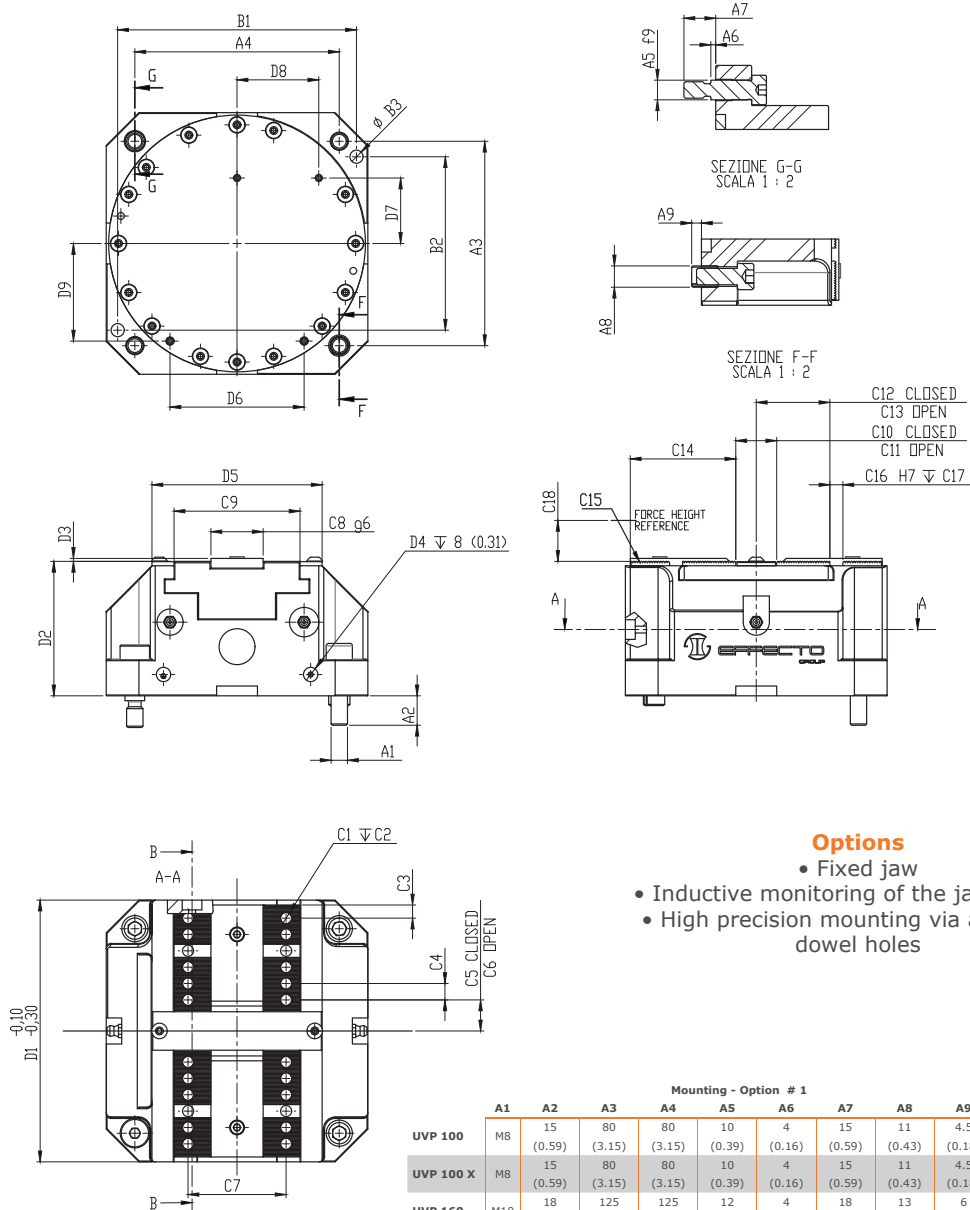

Options

- Fixed jaw
- Inductive monitoring of the jaw position
- High precision mounting via alignment dowel holes

		Mounting - Option # 1							Mounting - Option # 2				
		A1	A2	A3	A4	A5	A6	A7	A8	A9	B1	B2	B3
UVP 100	M8	15 (0.59)	80 (3.15)	80 (3.15)	10 (0.39)	4 (0.16)	15 (0.59)	11 (0.43)	4.5 (0.18)	90 (3.54)	64 (2.52)	6 (0.24)	
	M8	15 (0.59)	80 (3.15)	80 (3.15)	10 (0.39)	4 (0.16)	15 (0.59)	11 (0.43)	4.5 (0.18)	90 (3.54)	64 (2.52)	6 (0.24)	
UVP 160	M10	18 (0.71)	125 (4.92)	125 (4.92)	12 (0.47)	4 (0.16)	18 (0.71)	13 (0.51)	6 (0.24)	146 (5.75)	106 (4.17)	8 (0.31)	
	M10	18 (0.71)	125 (4.92)	125 (4.92)	12 (0.47)	4 (0.16)	18 (0.71)	13 (0.51)	6 (0.24)	146 (5.75)	106 (4.17)	8 (0.31)	

		Finger Application										Informational Dimensions																
		C1	C2	C3	C4	C5	C6	C7	C8	C9	C10	C11	C12	C13	C14	C15	C16	C17	C18	D1	D2	D3	D4	D5	D6	D7	D8	D9
UVP 100	M6	9 (0.35)	7.5 (0.30)	7 (0.28)	15 (0.59)	17 (0.67)	35 (1.38)	20 (0.79)	46 (1.81)	21 (0.83)	25 (0.98)	26 (1.02)	28 (1.10)	37.5 (1.48)	1.5 X 60°	6 (0.24)	2.7 (0.11)	16 (0.63)	100 (3.94)	69.2 (2.72)	1.8 (0.07)	G 1/8"	64 (2.52)	55 (2.17)	32 (1.26)	29.5 (1.16)	34.5 (1.36)	
	UVH 100 X	M6	9 (0.35)	7.5 (0.30)	7 (0.28)	14.5 (0.57)	20.5 (0.81)	35 (1.38)	20 (0.79)	46 (1.81)	19 (0.75)	31 (1.22)	25.5 (1.00)	31.5 (1.24)	1.5 X 60°	6 (0.24)	2.7 (0.11)	16 (0.63)	100 (3.94)	69.2 (2.72)	1.8 (0.07)	G 1/8"	64 (2.52)	55 (2.17)	32 (1.26)	29.5 (1.16)	34.5 (1.36)	
UVP 160	M8	12 (0.47)	8 (0.31)	10 (0.39)	19 (0.75)	22 (0.87)	60 (2.36)	32 (1.26)	77 (3.03)	25 (0.98)	31 (1.22)	45 (1.77)	48 (1.89)	64.5 (2.54)	1.5 X 60°	8 (0.31)	3.2 (0.13)	25 (0.98)	160 (6.30)	82.2 (3.24)	1.8 (0.07)	G 1/8"	104 (4.09)	82 (3.23)	40 (1.57)	50 (1.97)	59.7 (2.35)	
	UVP 160 X	M8	12 (0.47)	11.2 (0.44)	10 (0.39)	18.8 (0.74)	26.8 (1.06)	60 (2.36)	32 (1.26)	77 (3.03)	25 (0.98)	41 (1.61)	44.8 (1.76)	52.8 (2.08)	67.5 (2.66)	1.5 X 60°	8 (0.31)	3.2 (0.13)	25 (0.98)	160 (6.30)	82.2 (3.24)	1.8 (0.07)	G 1/8"	104 (4.09)	82 (3.23)	40 (1.57)	50 (1.97)	59.7 (2.35)

* Dimensions are in millimeters (inches).

** All dimensions are descriptive and subject to variation for technical upgrading. We reserve the right to make variations without prior notification



Applied Robotics
648 Saratoga Road
Glenville, NY 12302 USA
Tel. +1 518 384 1000 Fax +1.5183841200
info@appliedrobotics.com
www.appliedrobotics.com



EFFECTO GROUP S.p.A.
Via Roma, 141/143
28017 San Maurizio d'Opaglio (NO) - Italy
Tel. +39 0322 96142 Fax +39 0322 967453
info@effectogroup.com
www.effectogroup.com

