

INSTALLATION SHEET

SOLID FOLD

extang
AMERICA'S BEST
SELLING TONNEAUS

The SOLID FOLD top comes fully assembled. Note any damaged or missing components before installing.

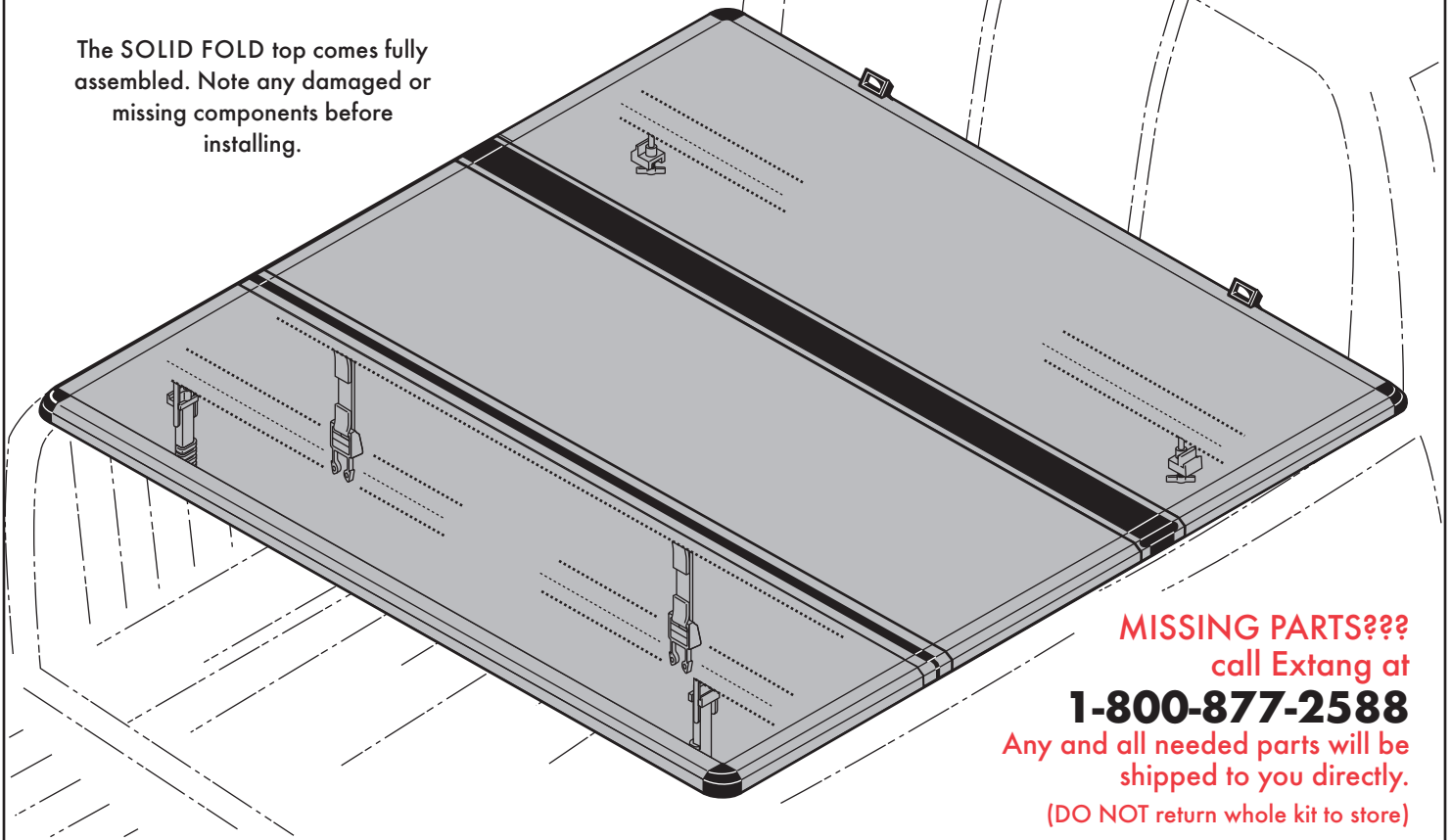

MISSING PARTS???
call Extang at
1-800-877-2588
Any and all needed parts will be
shipped to you directly.
(DO NOT return whole kit to store)

1



Wash truck bed.

2

Place assembled cover over
cab end of truck box.

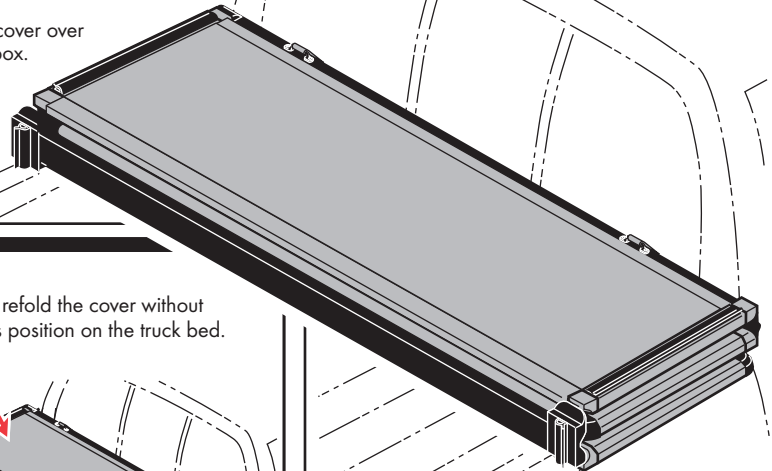

3

Unfold the cover fully and adjust
position over the truck bed for
proper cab/tail alignment.

Carefully refold the cover without
shifting its position on the truck bed.

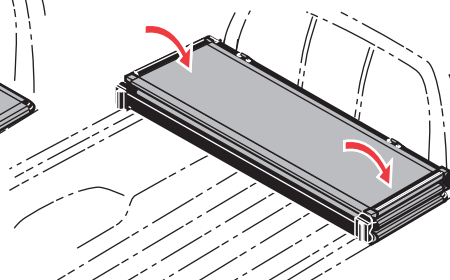
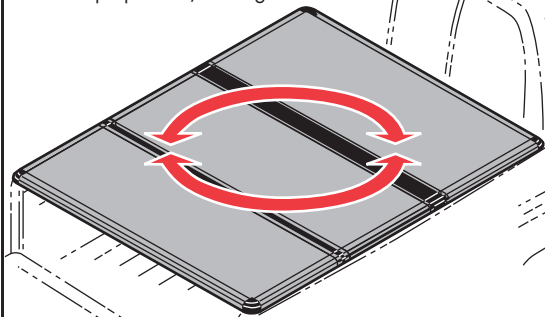

Extang Corporation
5400 S. State Road
Ann Arbor, MI 48108
734 677-0444, Fax: 734 677-8409

Register your warranty at:

extang.com

Item No. 0182-1402 RH Printed in U.S.A.

4

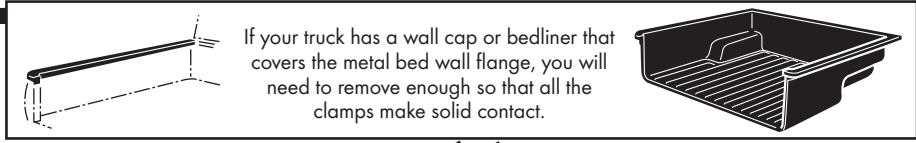

If your truck has a wall cap or bedliner that covers the metal bed wall flange, you will need to remove enough so that all the clamps make solid contact.

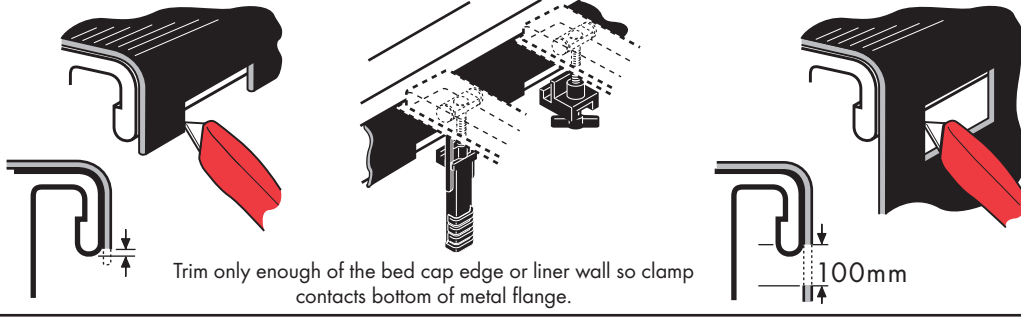

Trim only enough of the bed cap edge or liner wall so clamp contacts bottom of metal flange.

5

Ensure clamp is positioned under bed wall flange. Hand tighten until clamp contacts, then tighten an additional two turns.

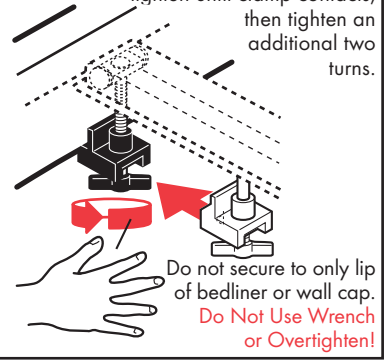

6

With tailgate open and front clamps secure, completely close the cover.

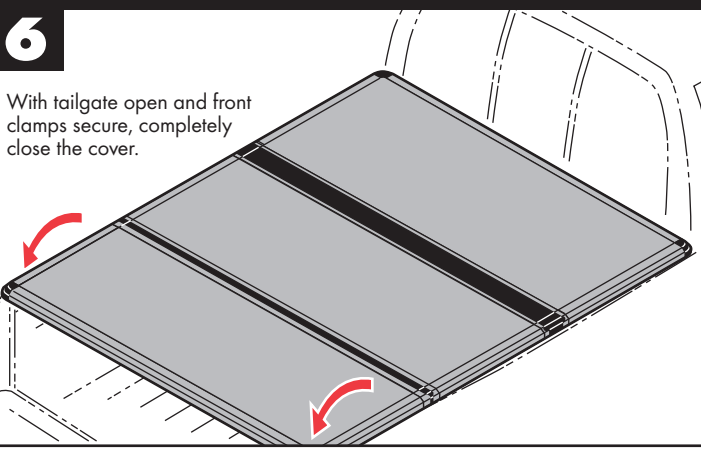

7

Slide rear clamp out to the bed wall.

Pull rear clamp down and hook under bottom edge of bed wall flange.

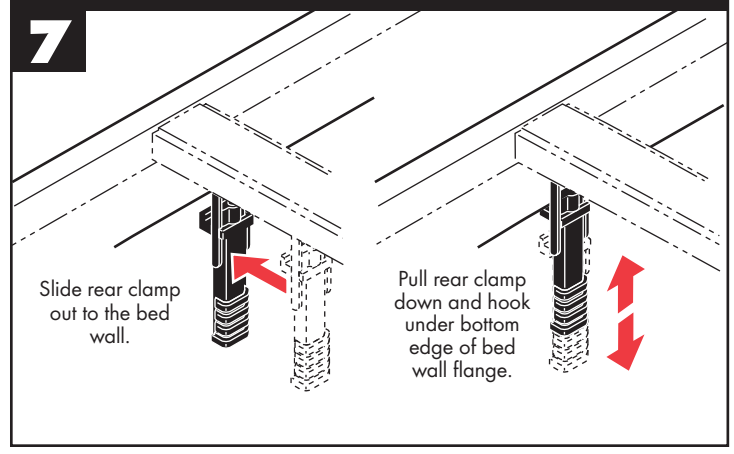

8

It is very convenient to drive with the SOLID FOLD cover open. Release the rear clamps and fold the cover forward.

Fold the cover forward and fasten the straps in the middle section to the front rail.

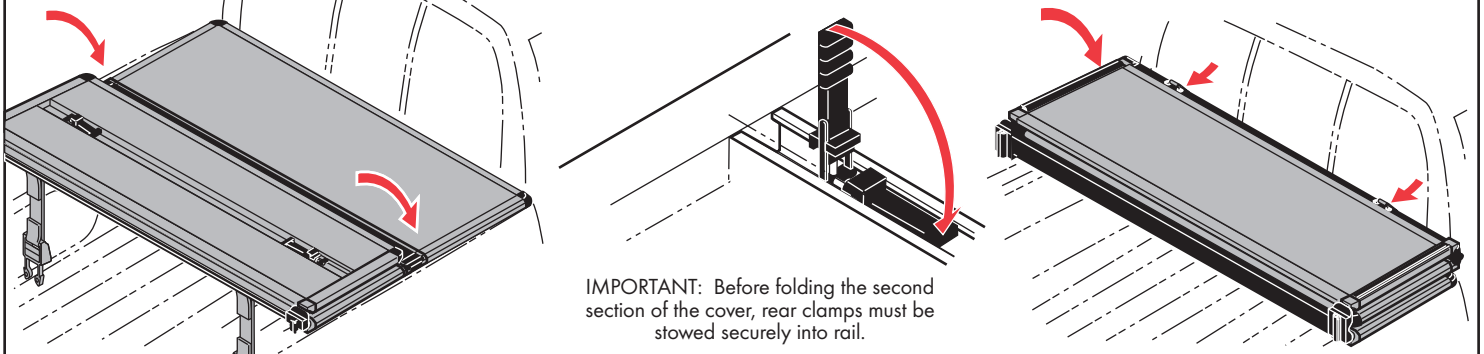

IMPORTANT: Before folding the second section of the cover, rear clamps must be stowed securely into rail.

Remove any snow or foreign matter before folding cover.

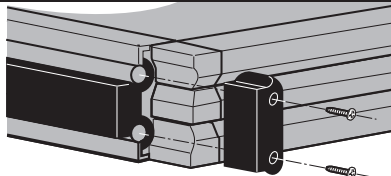

To remove foreign matter from panel hinges, remove one end cap and slide panels apart. Reassemble after cleaning.

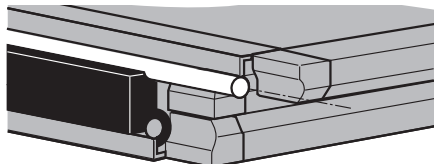

IMPORTANT NOTICE

While driving, cover must be completely flat and secure with all four clamps in the closed position or completely folded up (all panels) and secured at the cab. DO NOT DRIVE with cover in partially opened position.

