

# INSTALLATION SHEET

## EXTANG RT TONNO TOOLBOX

**extang**  
AMERICA'S BEST  
SELLING TONNEAUS

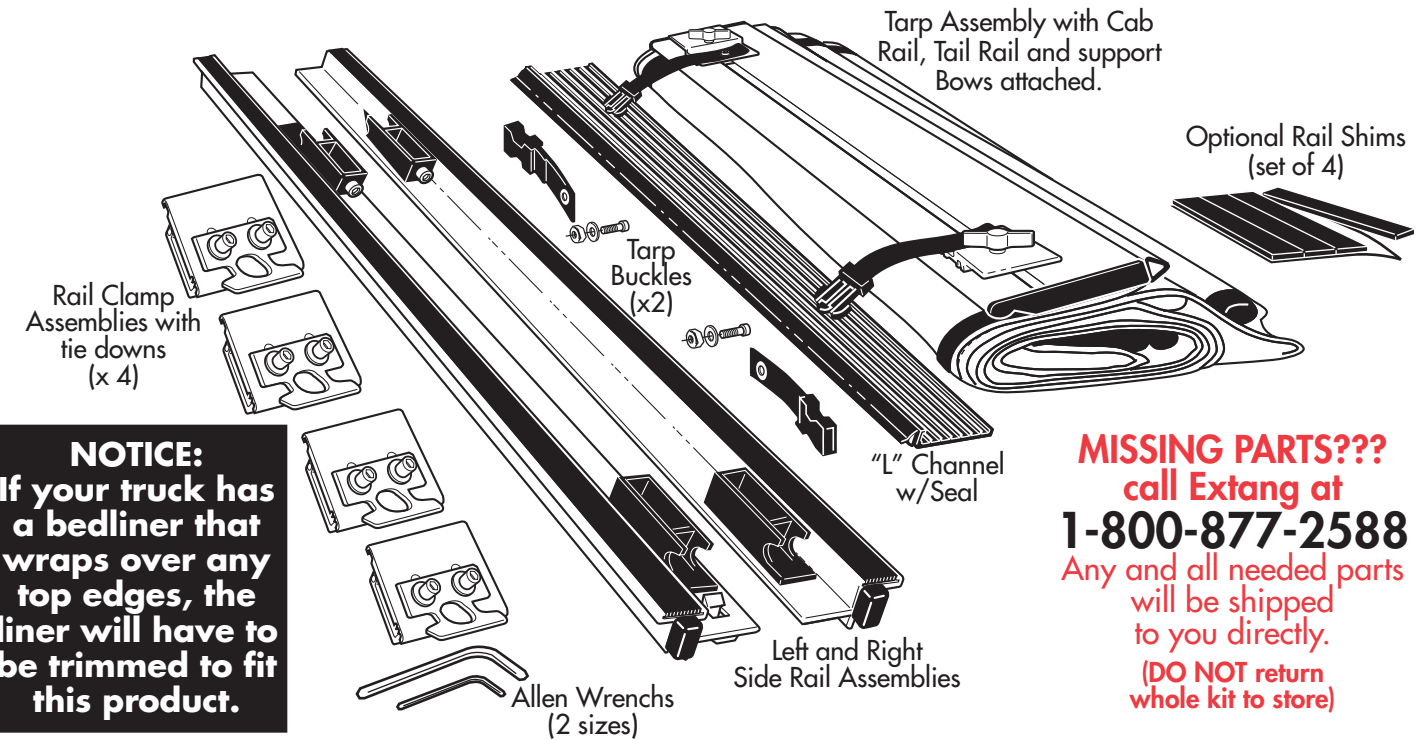

**NOTICE:**  
If your truck has a bedliner that wraps over any top edges, the liner will have to be trimmed to fit this product.

**MISSING PARTS???**  
call Extang at  
**1-800-877-2588**  
Any and all needed parts will be shipped to you directly.  
**(DO NOT return whole kit to store)**

PARTS INCLUDED IN YOUR KIT. You may want to lay them out in this manner for accessibility.

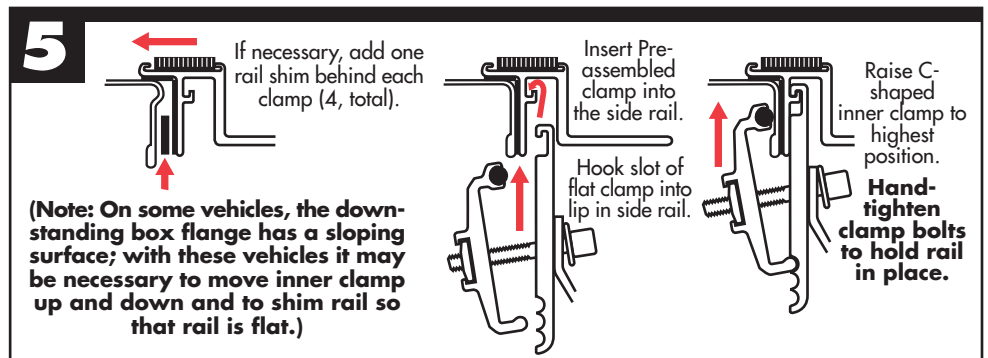
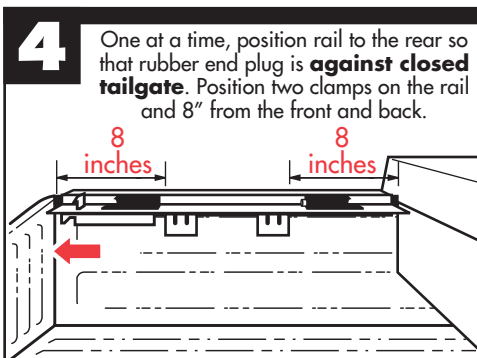
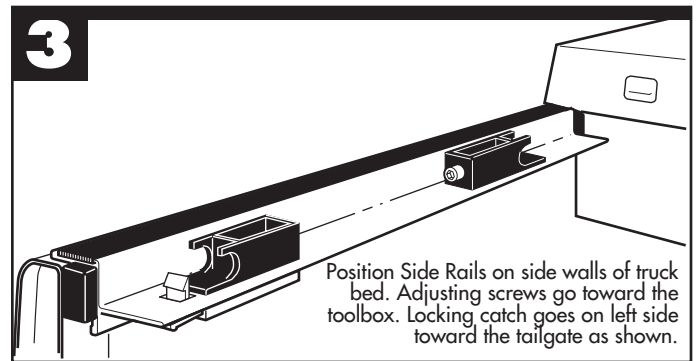
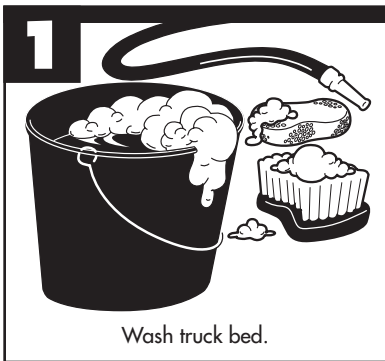

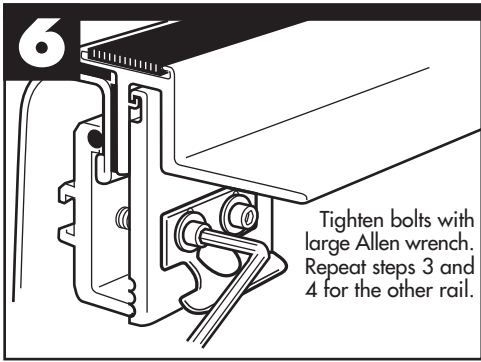

**6**

Tighten bolts with large Allen wrench. Repeat steps 3 and 4 for the other rail.

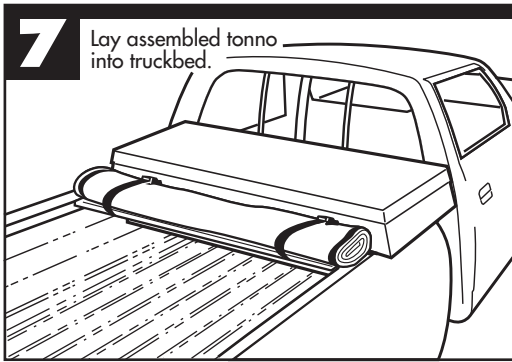

**7**

Lay assembled tonno into truckbed.

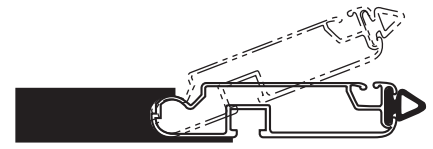

Engage the round edge of the cab rail to the spring blocks and rotate the rail down.

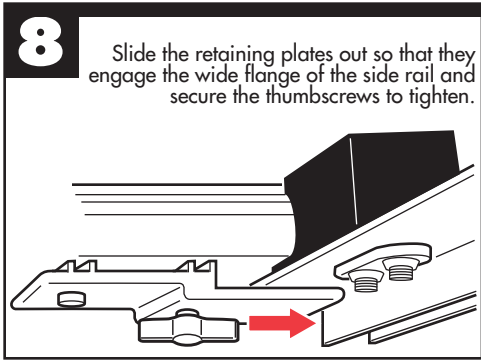

**8**

Slide the retaining plates out so that they engage the wide flange of the side rail and secure the thumbscrews to tighten.

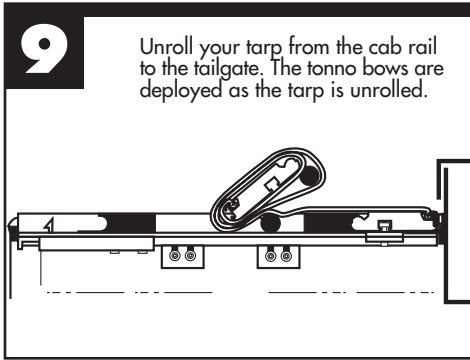

**9**

Unroll your tarp from the cab rail to the tailgate. The tonno bows are deployed as the tarp is unrolled.

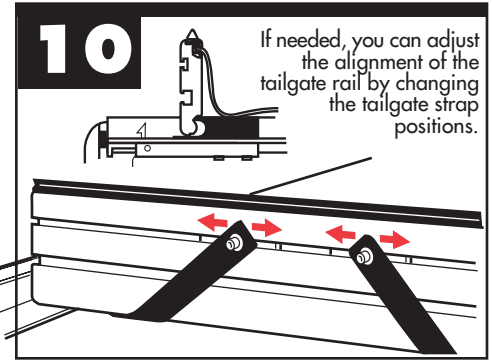

**10**

If needed, you can adjust the alignment of the tailgate rail by changing the tailgate strap positions.

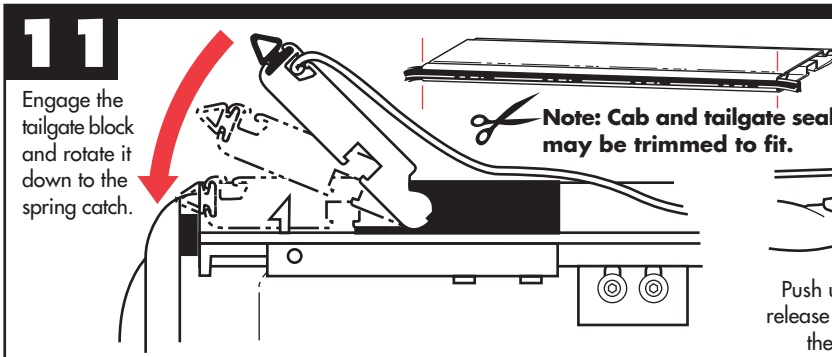

**11**

Engage the tailgate block and rotate it down to the spring catch.

**Note:** Cab and tailgate seal may be trimmed to fit.

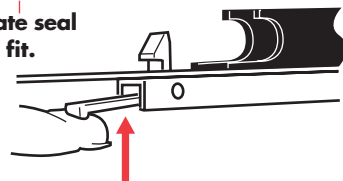

Push up on spring tab to release tonno catch and roll the tonno forward.

To adjust the tension of the tarp, rotate the screw using the large Allen Wrench.

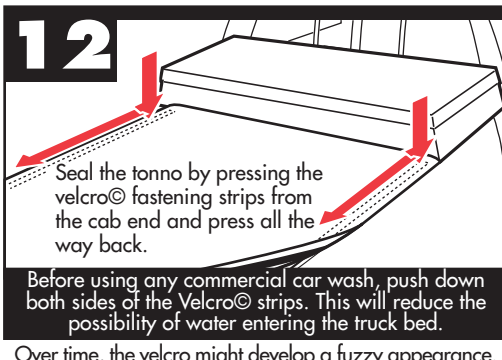
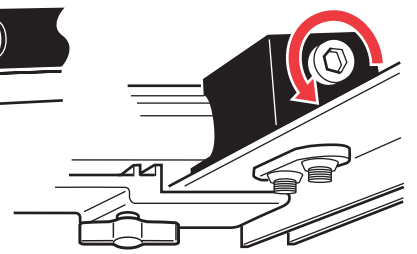

**12**

Seal the tonno by pressing the velcro® fastening strips from the cab end and press all the way back.

Before using any commercial car wash, push down both sides of the Velcro® strips. This will reduce the possibility of water entering the truck bed.

Over time, the velcro might develop a fuzzy appearance. This is normal and will increase the holding strength.

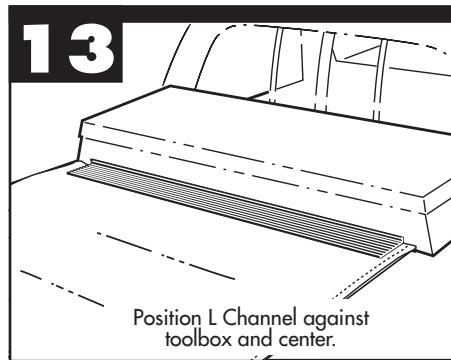

**13**

Position L Channel against toolbox and center.



**14**

Mark and Drill into Toolbox

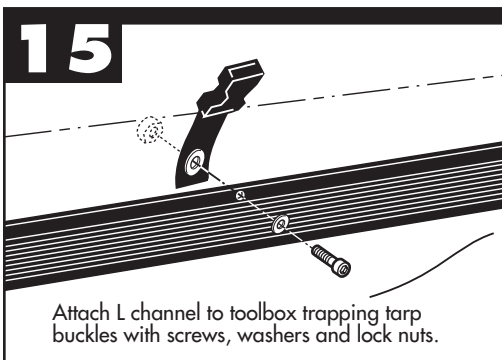

**15**

Attach L channel to toolbox trapping tarp buckles with screws, washers and lock nuts.

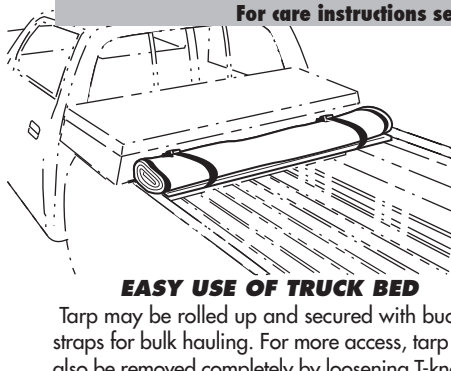

For care instructions see tag on underside of tarp

**EASY USE OF TRUCK BED**

Tarp may be rolled up and secured with buckle straps for bulk hauling. For more access, tarp can also be removed completely by loosening T-knobs.

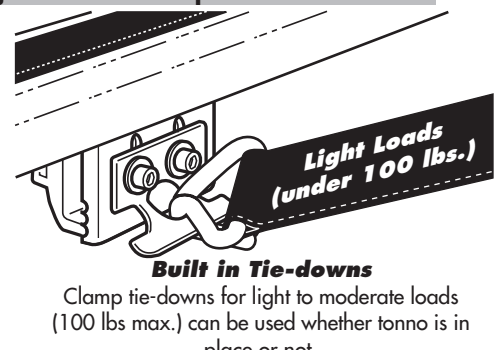

**Built in Tie-downs**

Clamp tie-downs for light to moderate loads (100 lbs max.) can be used whether tonno is in place or not.

**Light Loads (under 100 lbs.)**