

2017 VAN SHELVING



BUYERS' GUIDE

RANGERTM
DESIGN

Helping Mobile Technicians Work More Effectively by Providing Organized Storage Solutions

At Ranger Design, we believe more is possible.

We believe work vehicles and the technicians that drive them can become more organized, more efficient, more productive and more profitable. At Ranger Design we're committed to bringing you the products and services that make that possible.

More means helping you choose the right work van for your

application, as well as giving you engineering support and expert advice to help design the most efficient work space in your new vehicle.

More also means getting that new van outfitted and on the road faster, so you can start using it for the reason you bought it.

We're committed to bringing you more, because we believe more is possible.



MORE IS POSSIBLE



INSTALL TIMES

Install time is estimated based on the average time taken by an experienced Ranger Design installer.

UPDATED DATA

At the moment of publication, the data included in this directory was up-to-date.

Any corrections, modifications and discontinued product occurring after publication date are reflected in our Buyers' Guide available on our website.

The digital version of all our catalogs is always updated as modifications occur during the year.

TABLE OF CONTENTS

CHOOSE A PRODUCT LINE	P. 4
HOW TO BUY	P. 6
GETTING STARTED	P. 8
PLAN YOUR VAN OUTFIT – LAYOUT GUIDES	P. 10
SHELVING	P. 22

Choose A Product Line To Match Your Needs

Ranger Fleetline and Proline product groups ensure that fleets of any size have the best equipment to fit their budget, trade or fuel saving targets.



Ranger Fleetline shown



Ranger Proline shown

	MATERIAL	BENEFITS	PRODUCTS	WARRANTY
<p>WHY BUY RANGER FLEETLINE? You want better quality and price than other steel products on the market.</p>	Steel	Tough Low cost Quiet	Shelving, Partitions, Drawers, Accessories	3 years*
<p>WHY BUY RANGER PROLINE? You want the toughest, quietest product on the market. You need to optimize payload without sacrificing quality.</p>	Aluminum	Toughest Lightweight Quiet	Shelving, Partitions, Drawers, Accessories, Ladder Racks	10 years*

*Ranger Design Inc. van equipment is warranted to be free from defects in material and workmanship under normal use and service for the period indicated, from the date of the original retail purchase, when installed per Ranger Design instructions in the original vehicle. Please contact Customer Service for full warranty details. Email: cs@rangerdesign.com

Throughout the catalog **FLEETLINE** products are depicted with yellow and **PROLINE** products with black.

1-800-565-5321
7 A.M. – 8 P.M. EST

World Class Customer Service



Real people, ready to answer in 2 rings or less*

We are pleased to offer efficient, personalized service and to answer all questions regarding:

- › Pricing/Quoting
- › Product install
- › Order status
- › Consultation
- › Shipment status
- › New product availability
- › Product specifications
- › Warranty claims
- › Returns/Restocking
- › Vehicle specifications

*Call customer service and the phone will be answered in 2 rings or less. Yes, a real, live person working in one of our offices in North America is available to answer your questions. No automated attendant. No complicated phone tree and offshore service. Call us to experience the difference.

Over 350 Distributors Across the Continent

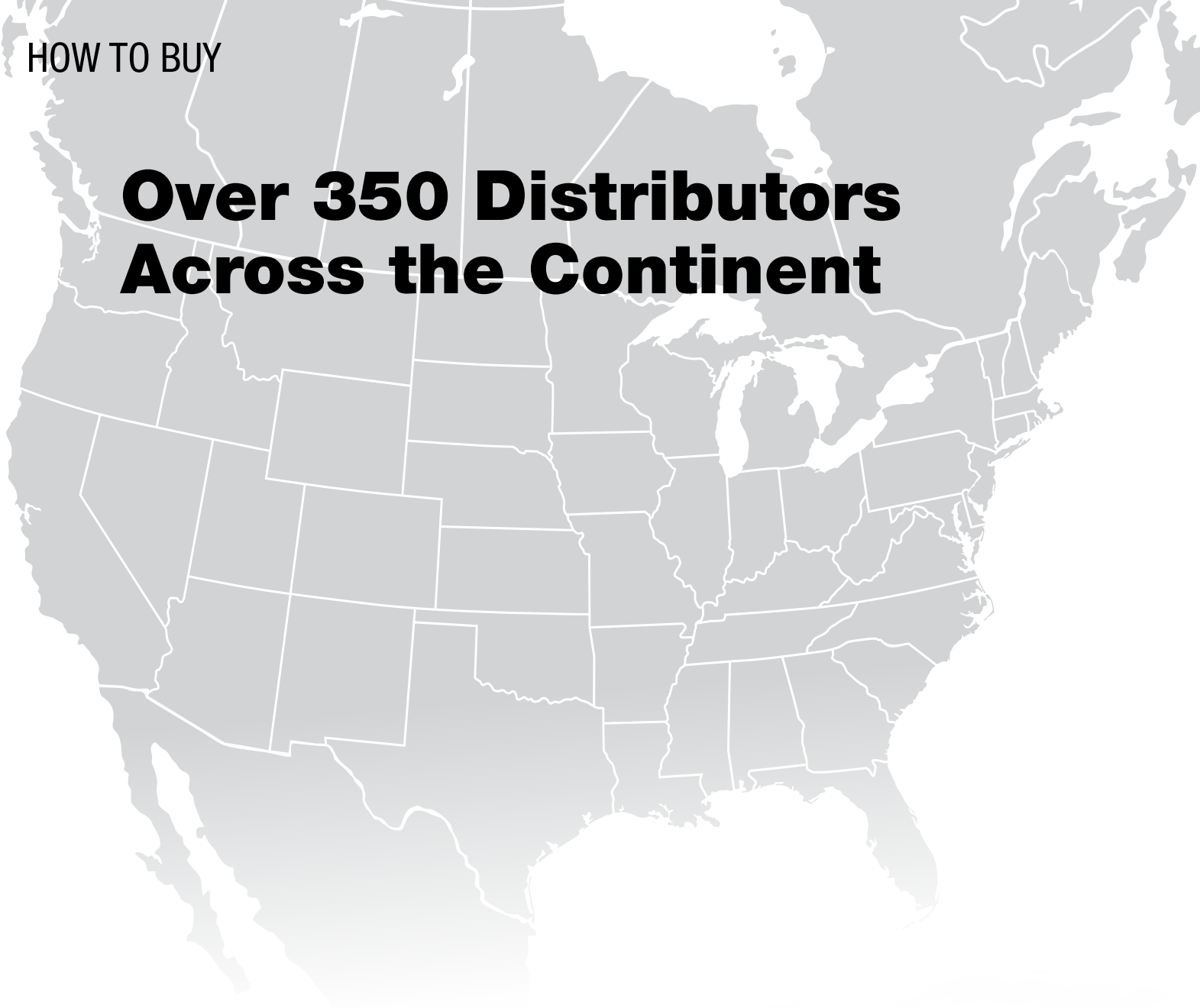

Regular Order

Quickship Order

Buy

Contact one of our 350 distributors
rangerdesign.com/find-dealer.

Ranger Quickship service is available
through your local distributor.

**Lead
Time**

Orders ship from our factory within
5 business days.

Orders placed with Ranger before 1PM EST will
ship from our factory in the next business day.



Throughout the catalog products and packages with this symbol
can be ordered through our Quickship service.

Turn-Key Fleet Services



Ship Through or Local Installation Across North America for all Types of Cargo Vans

We are pleased to offer efficient, personalized service and to answer all questions regarding:

1. Analysis

- › Cargo Needs Analysis
- › Custom 3D CAD Layouts
- › Hands-on Equipment Demo

2. Testing

- › Test Fitting
- › Pilot Build and Review
- › Optimize Package Based on Technician Feedback

3. Delivery

- › Delivery, Production and Installation Planning and Scheduling
- › Vehicle Status Tracking

4. Service

- › Dedicated Fleet Account Management Team
- › 300 Ranger Distributor Service Support Network
- › Live Customer Service

Take a few minutes to write down these simple steps

Plan your storage zones

For how long do you plan to use the vehicle? A year 2–5 years 10 years or more (see page 4)

Will payload capacity be an issue? Yes No Why? _____

What type of industry are you in? _____

What kind of partition do I need? (F zone)

Do I need to see my cargo or see out the side doors? Yes No

Do I need the ability to go from the cabin to the cargo area through the partition? Yes No

List the equipment/products you will need to store

Place the items that you need most often in the most accessible locations.

	How often will you use this?			Zone A-B-C-D-E
	Daily	Weekly	Monthly	
_____	<input type="checkbox"/>	<input type="checkbox"/>	<input type="checkbox"/>	_____
_____	<input type="checkbox"/>	<input type="checkbox"/>	<input type="checkbox"/>	_____
_____	<input type="checkbox"/>	<input type="checkbox"/>	<input type="checkbox"/>	_____
_____	<input type="checkbox"/>	<input type="checkbox"/>	<input type="checkbox"/>	_____
_____	<input type="checkbox"/>	<input type="checkbox"/>	<input type="checkbox"/>	_____

Will I need to carry larger objects Yes No

List the tools you will need to carry

Place heavy tools closest to the access doors.

	How often will you use this?			Zone A-B-C-D-E
	Daily	Weekly	Monthly	
_____	<input type="checkbox"/>	<input type="checkbox"/>	<input type="checkbox"/>	_____
_____	<input type="checkbox"/>	<input type="checkbox"/>	<input type="checkbox"/>	_____
_____	<input type="checkbox"/>	<input type="checkbox"/>	<input type="checkbox"/>	_____
_____	<input type="checkbox"/>	<input type="checkbox"/>	<input type="checkbox"/>	_____
_____	<input type="checkbox"/>	<input type="checkbox"/>	<input type="checkbox"/>	_____

What kind of ladder(s) will I be carrying? Step ladder Extension ladders
 Size _____ Size _____

Storage Zones

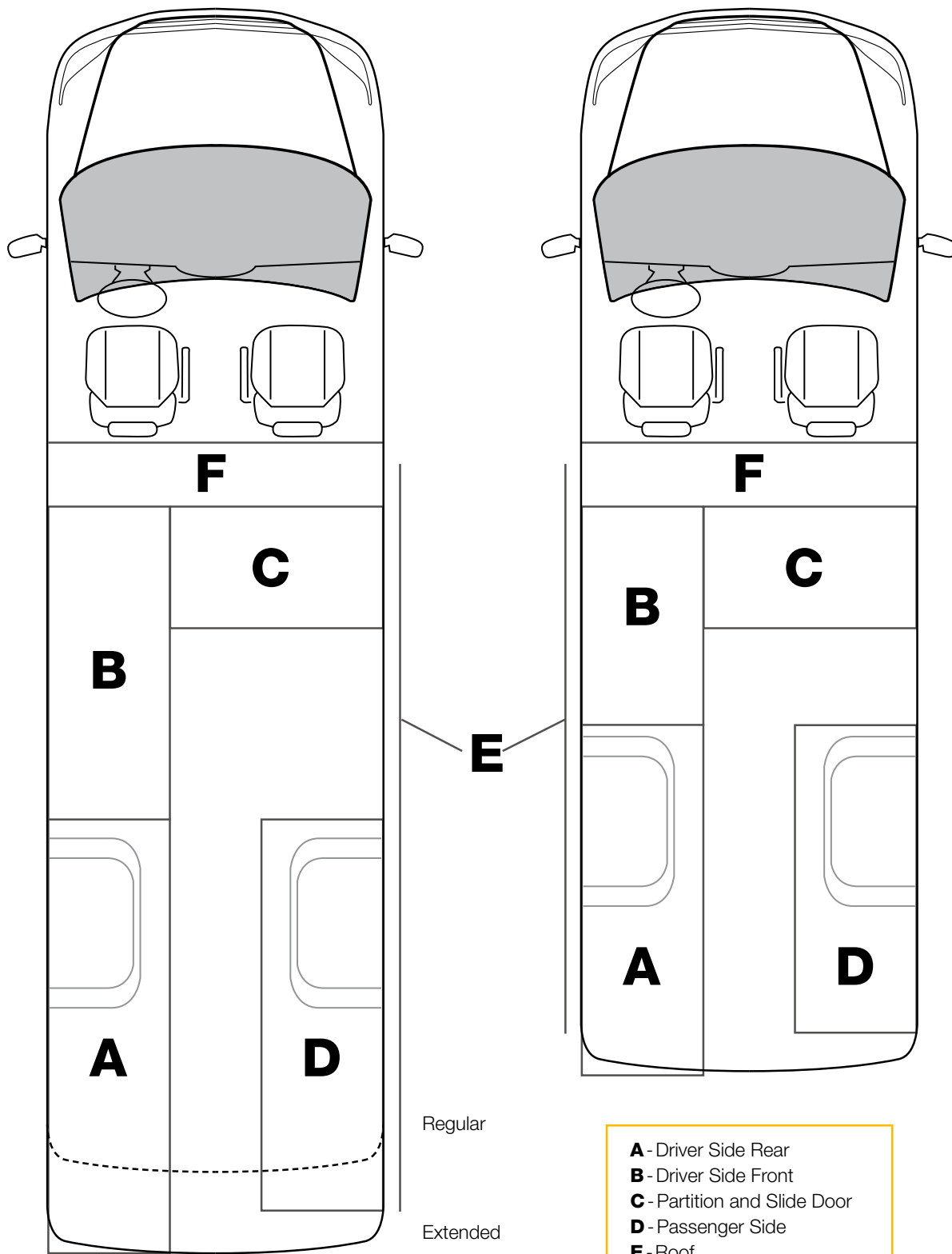

- A** - Driver Side Rear
- B** - Driver Side Front
- C** - Partition and Slide Door
- D** - Passenger Side
- E** - Roof
- F** - Partition

How to use the layout guide

INSIDE ROOF HEIGHT

To determine the maximum shelf height that can be used in the van.

PARTITION DEPTH

This indicates the space taken up by our partition for this vehicle. Please note that this measurement is determined by the partition that encroaches the most. Some partitions may take up less space. Take note that this measurement may not necessarily be on the floor.

DOOR OPENING

To determine where shelving will land in relation to the door opening. Use this measurement to determine the space available for drawer units.

DIMENSIONS IN RED

These dimensions indicate unique measurements for each wheelbase. Use red dimensions to determine the exact wheelbase of your van.

FLOOR SPACE

This area is usable floor space but due to curvature of the van there may not be the same available area at the roof. Please measure actual van for specific measurement at roof.

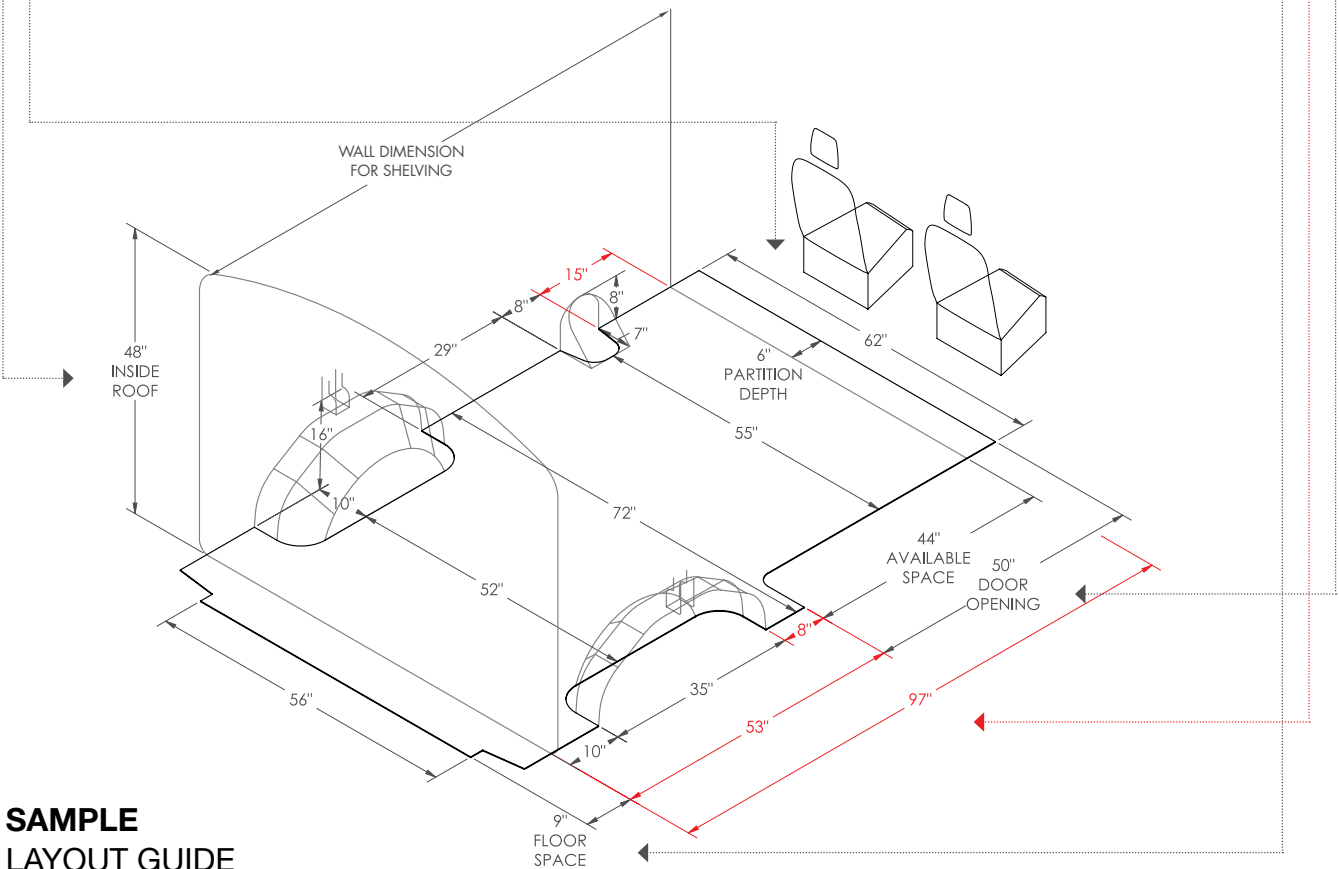

SAMPLE LAYOUT GUIDE

Wheelbase

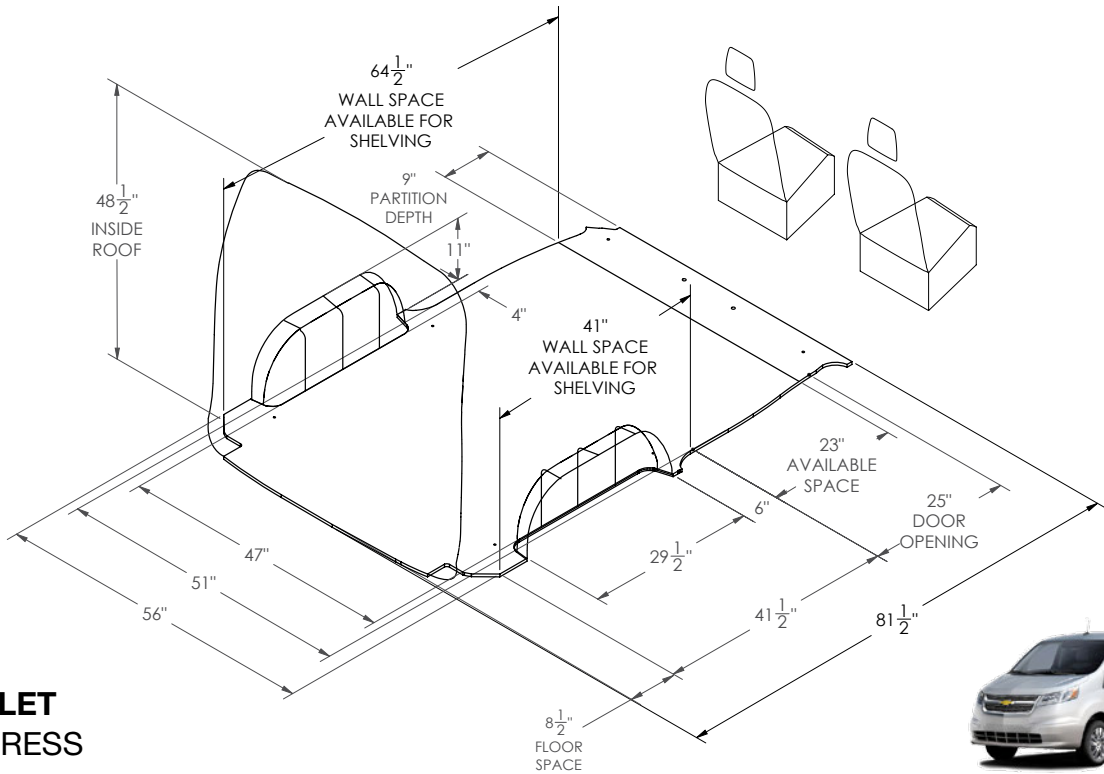

CHEVROLET CITY EXPRESS

Regular 115" Wheelbase

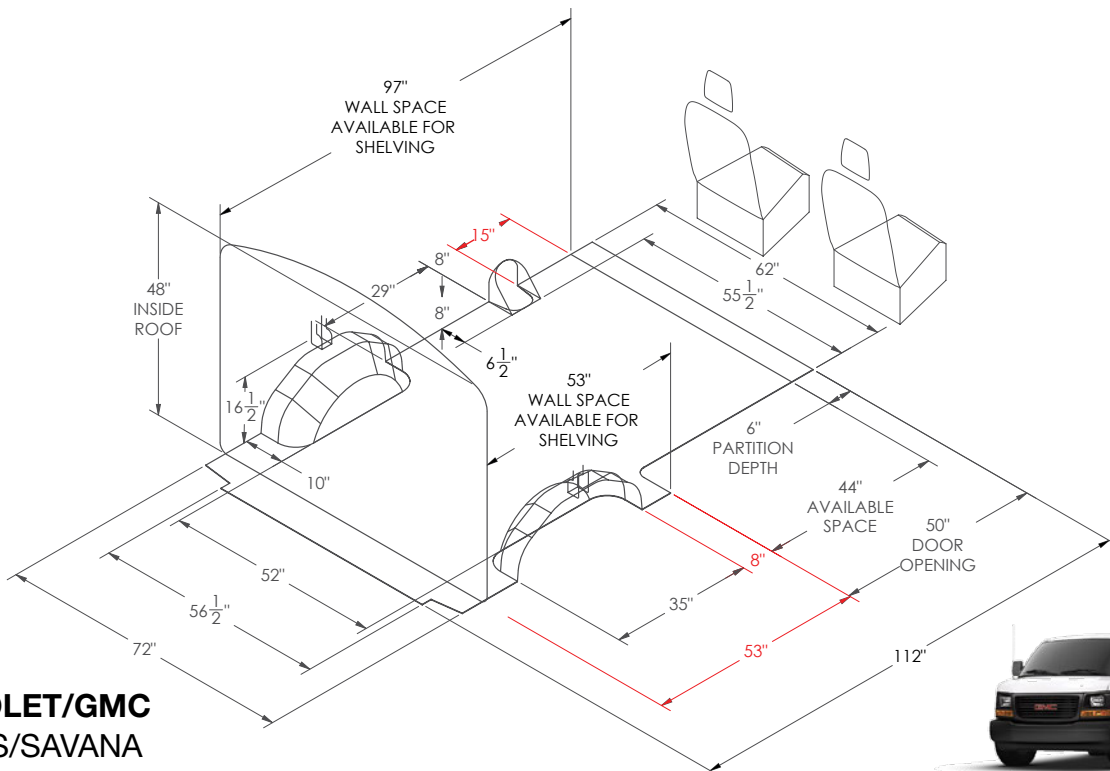

CHEVROLET/GMC EXPRESS/SAVANA

Regular 135" Wheelbase



LAYOUT GUIDES

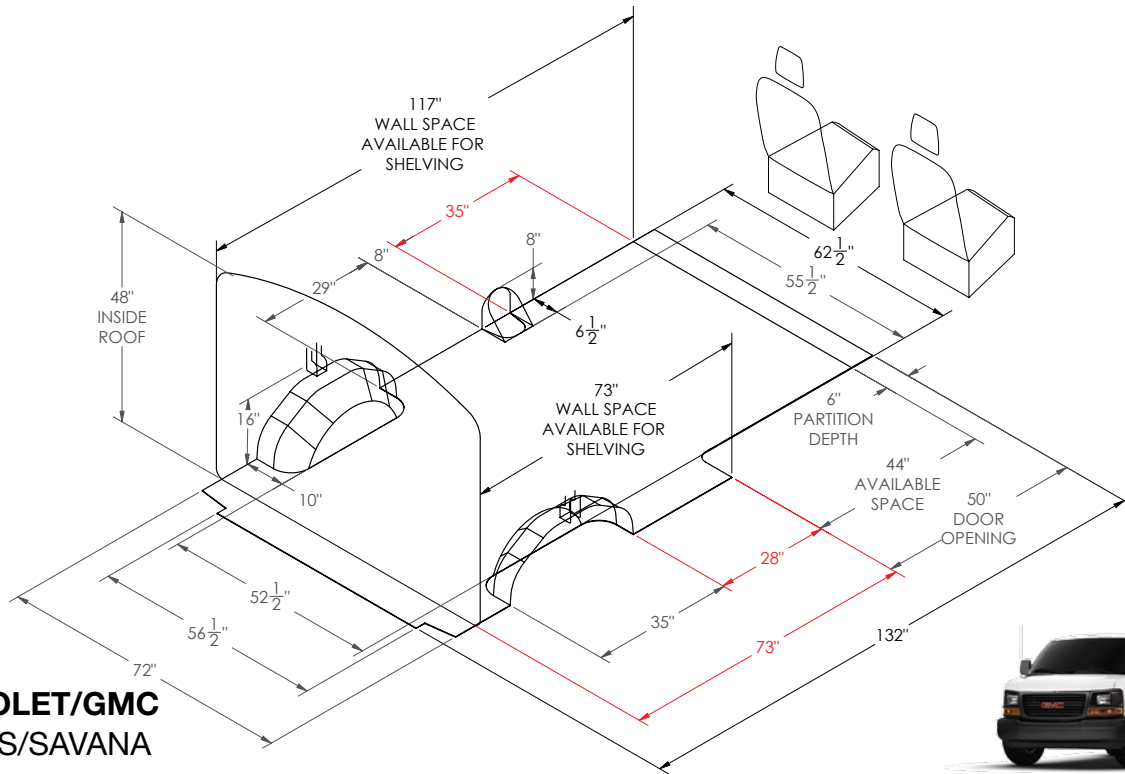

CHEVROLET/GMC EXPRESS/SAVANA

Extended 155" Wheelbase

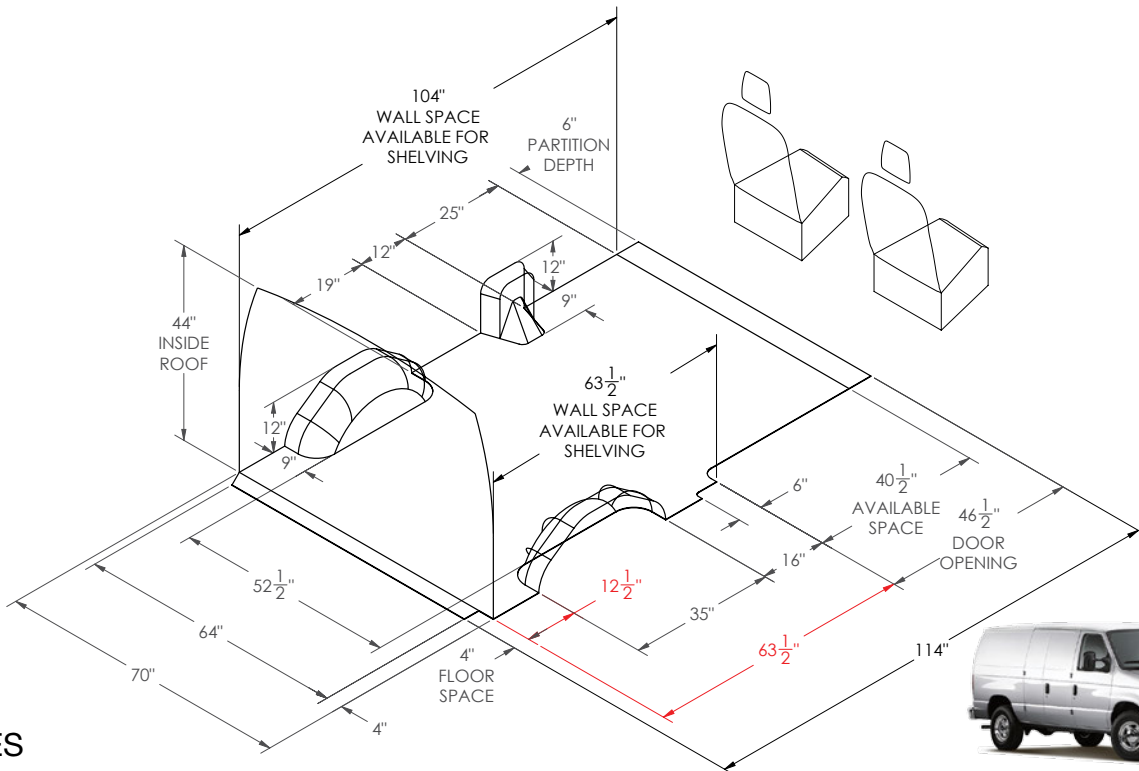

FORD E-SERIES

Regular 138" Wheelbase



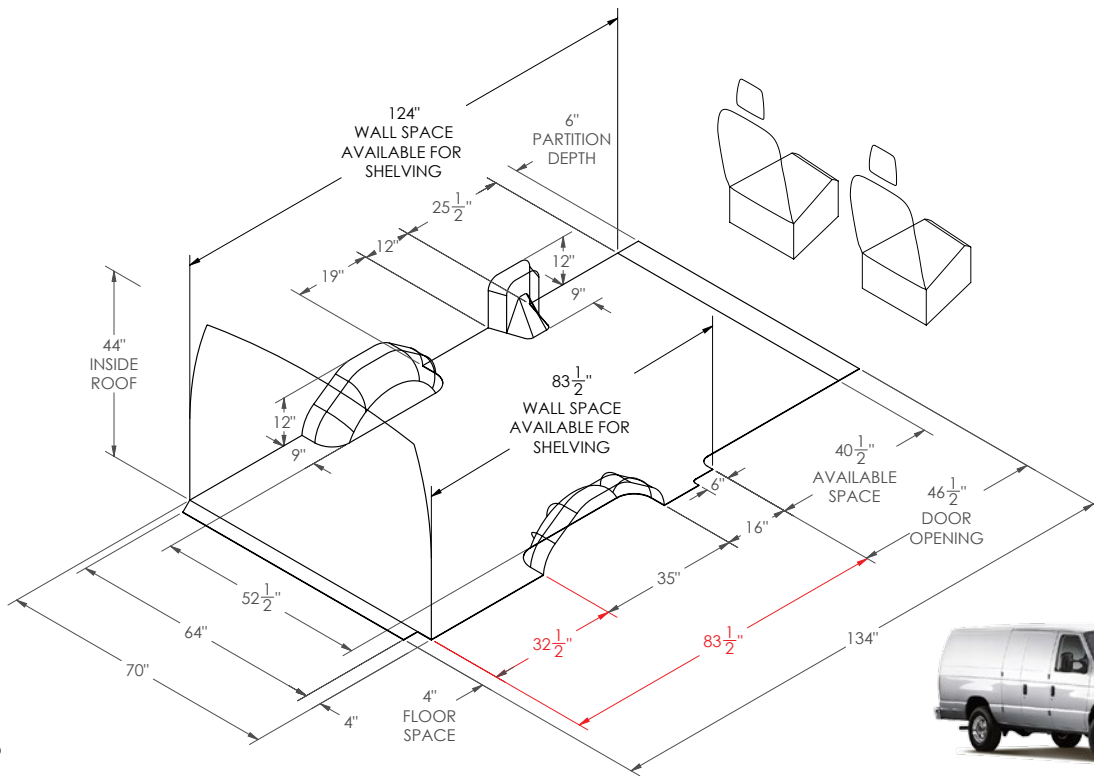

FORD E-SERIES

138" Wheelbase Extended

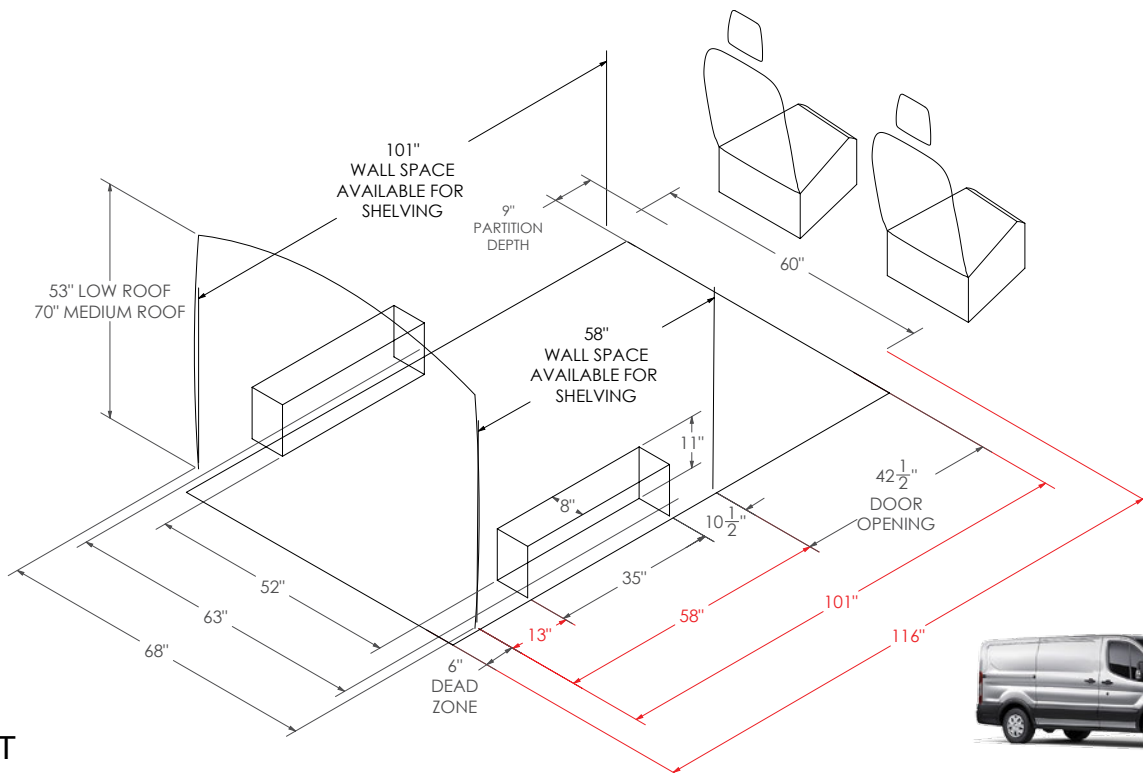

FORD TRANSIT

Regular 130" Wheelbase

LAYOUT GUIDES

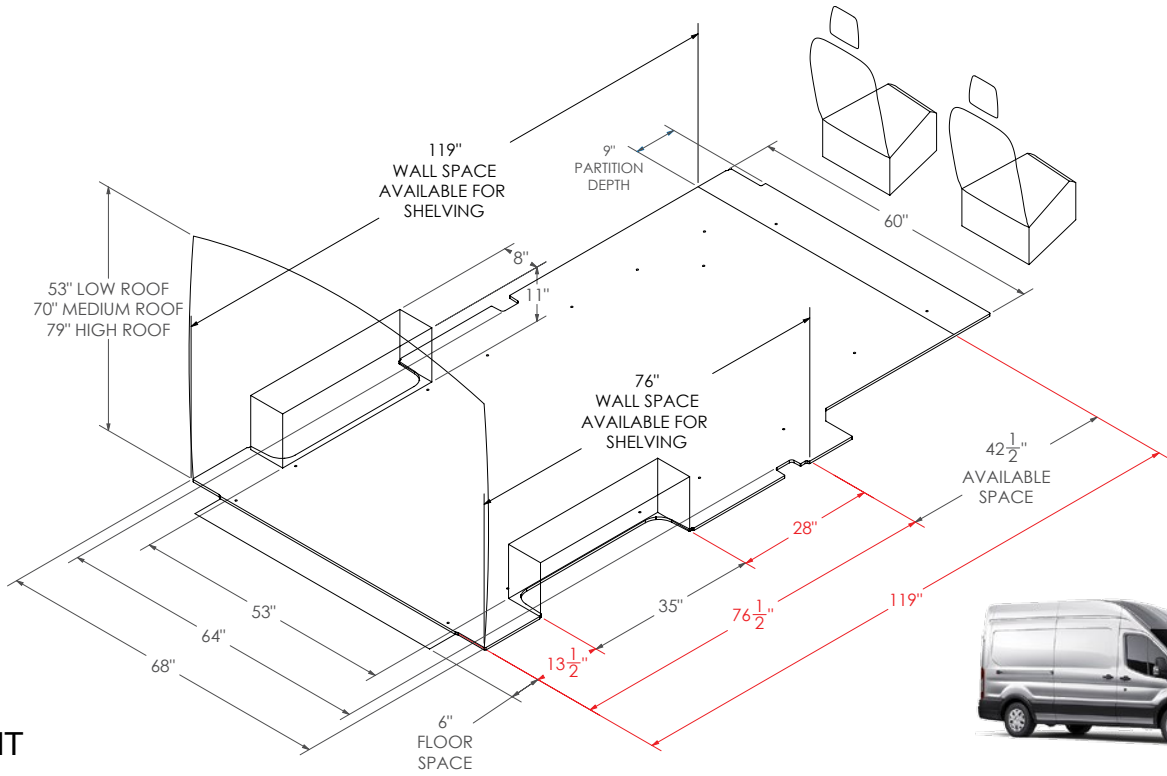

FORD TRANSIT

Long 148" Wheelbase

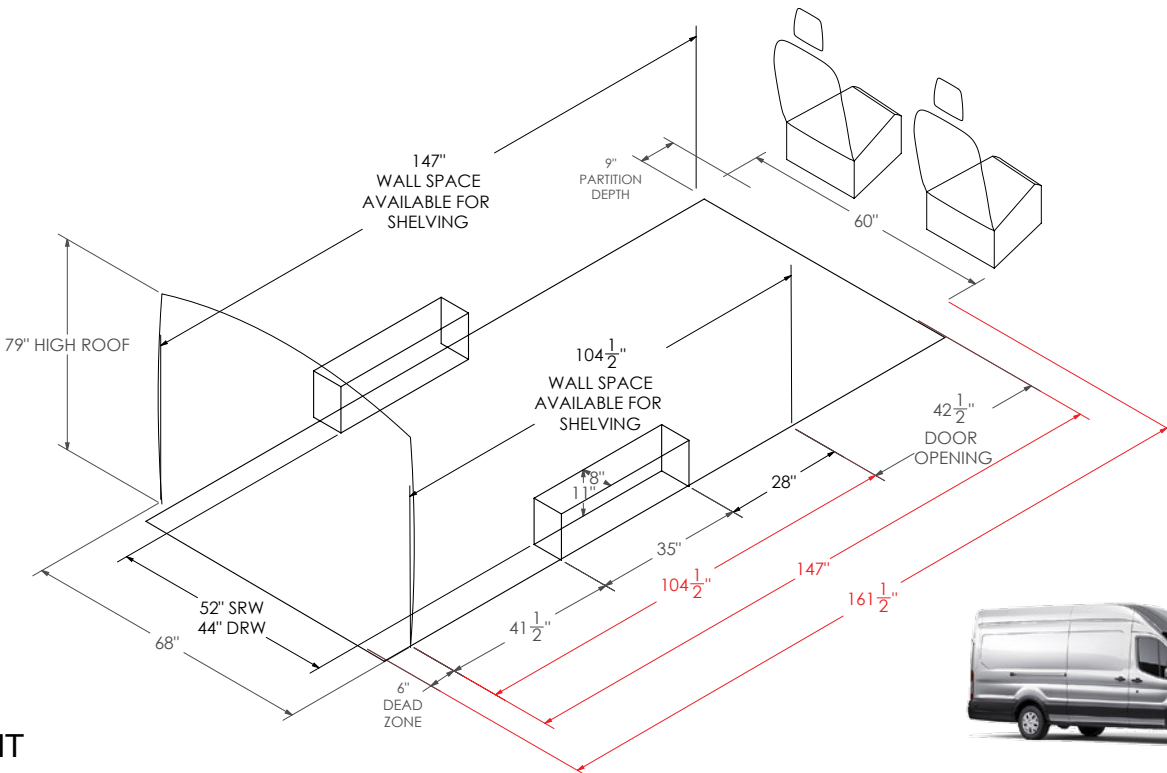

FORD TRANSIT

Long 148" Wheelbase Extended



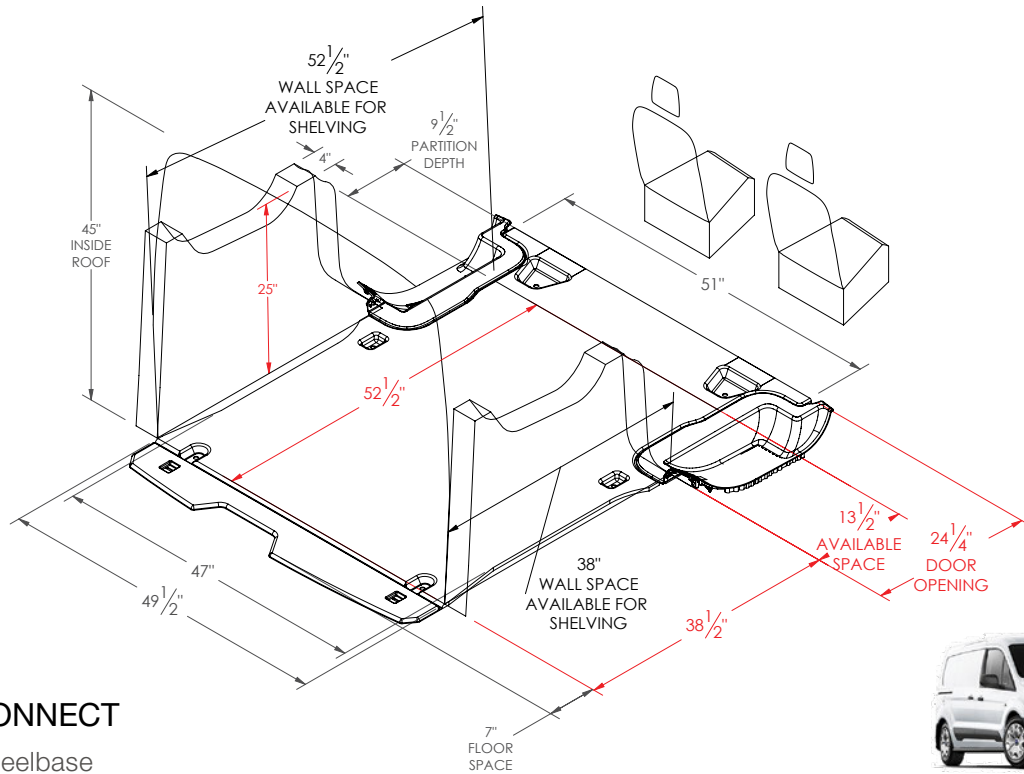

FORD TRANSIT CONNECT

Short 105" Wheelbase
Available in U.S. only

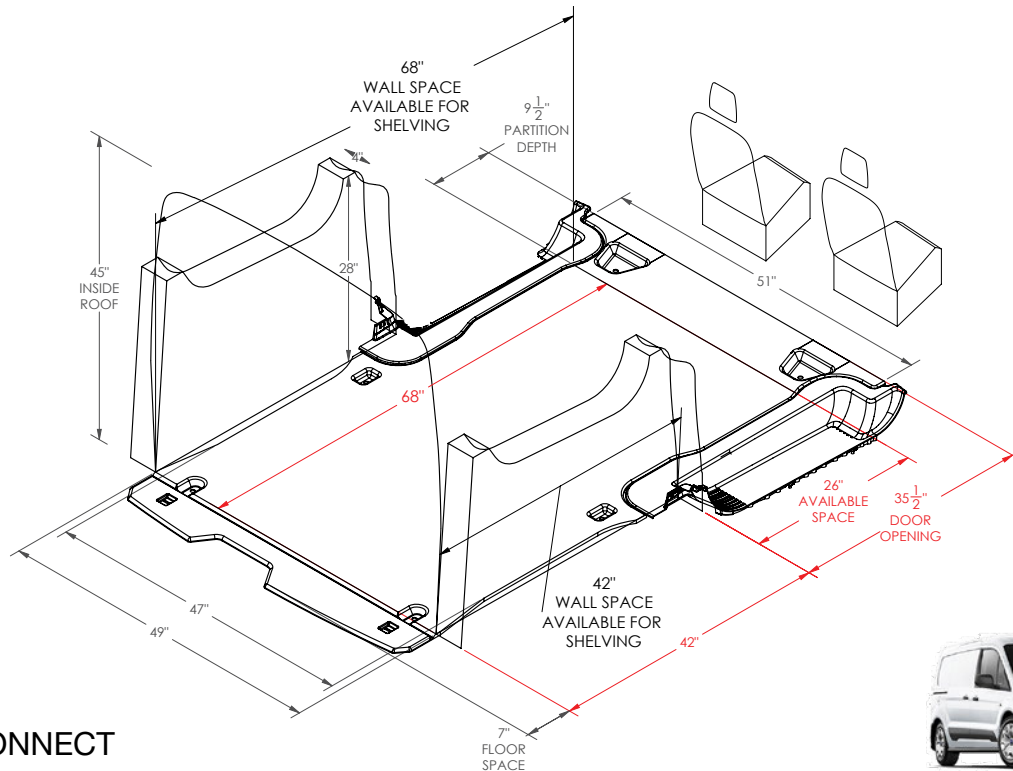

FORD TRANSIT CONNECT

Long 120.5" Wheelbase

LAYOUT GUIDES

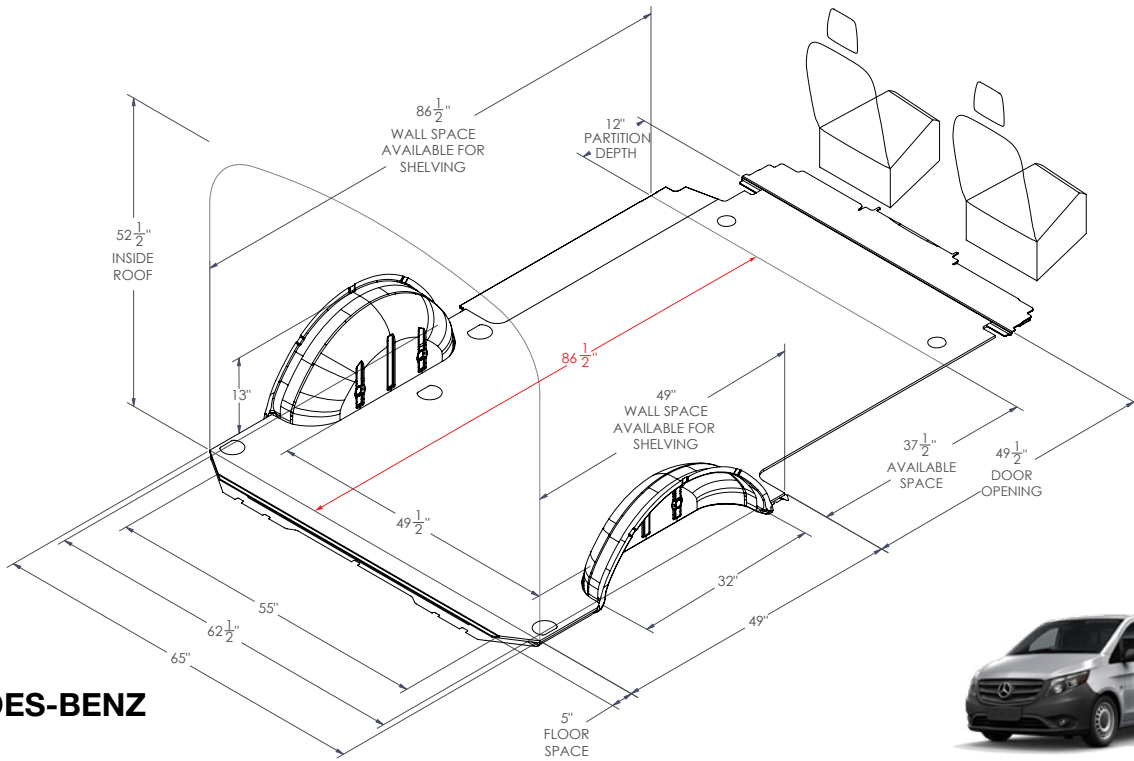

MERCEDES-BENZ METRIS

Regular 126" Wheelbase

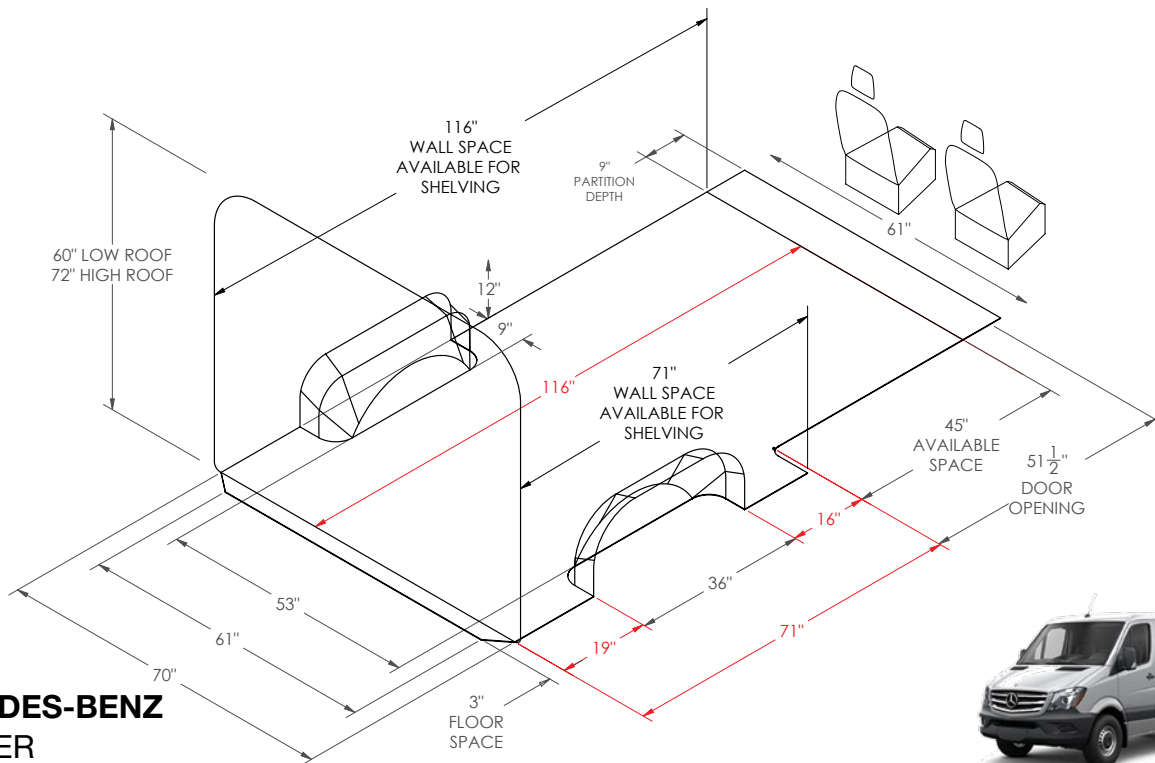

MERCEDES-BENZ SPRINTER

Regular 144" Wheelbase

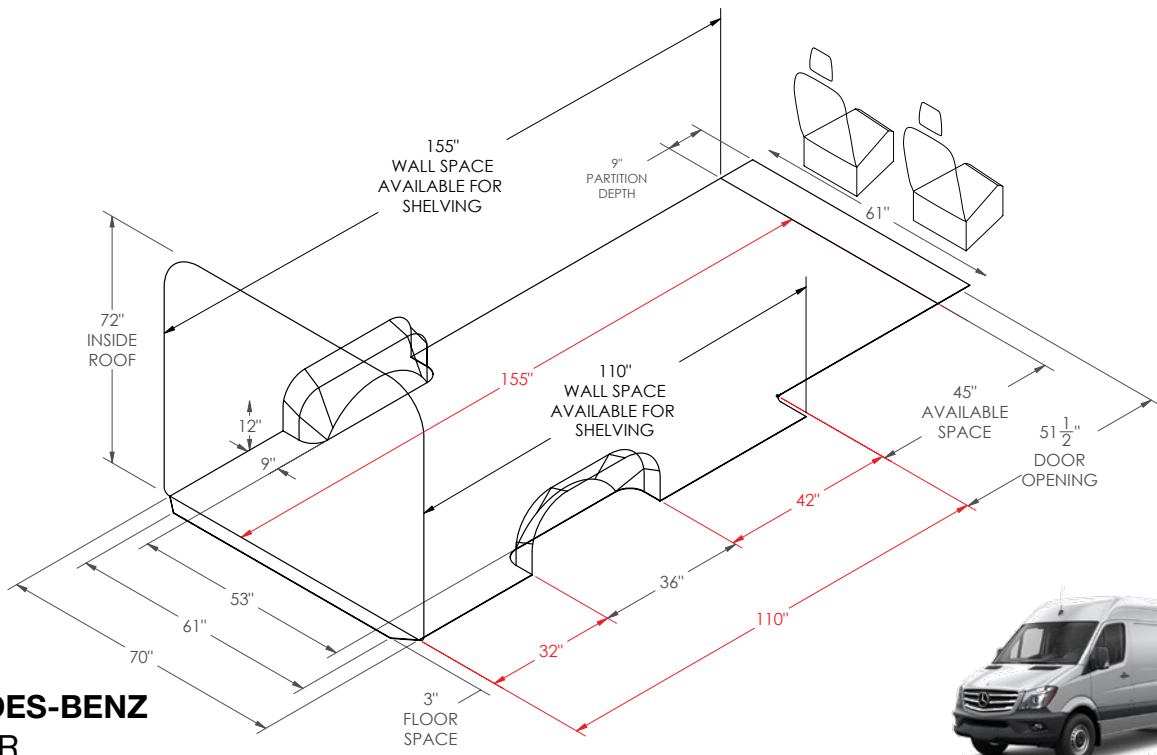

MERCEDES-BENZ SPRINTER

Long 170" Wheelbase

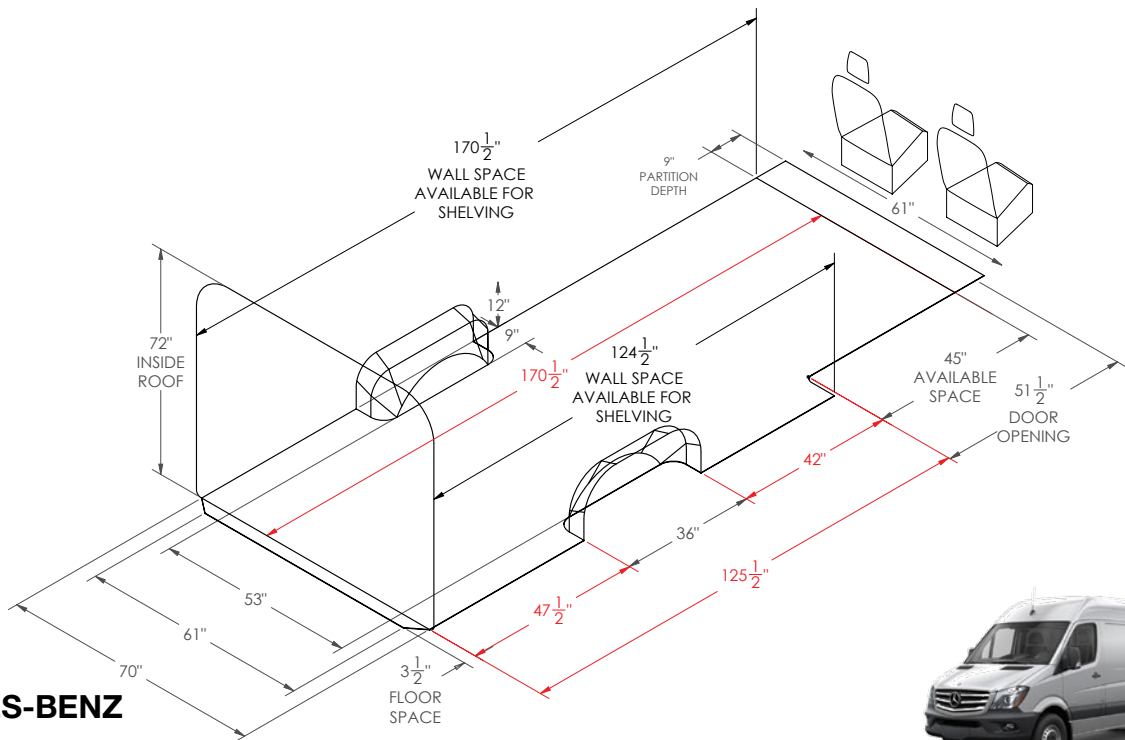

MERCEDES-BENZ SPRINTER

Extended 170" Wheelbase

LAYOUT GUIDES

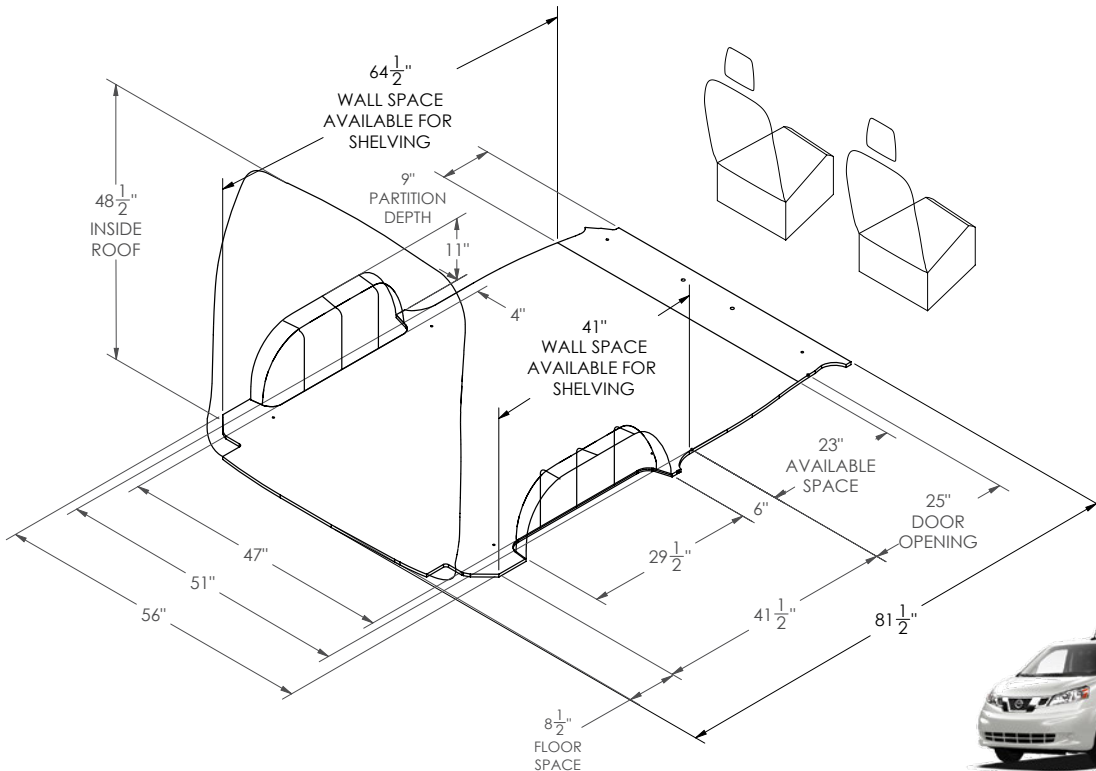
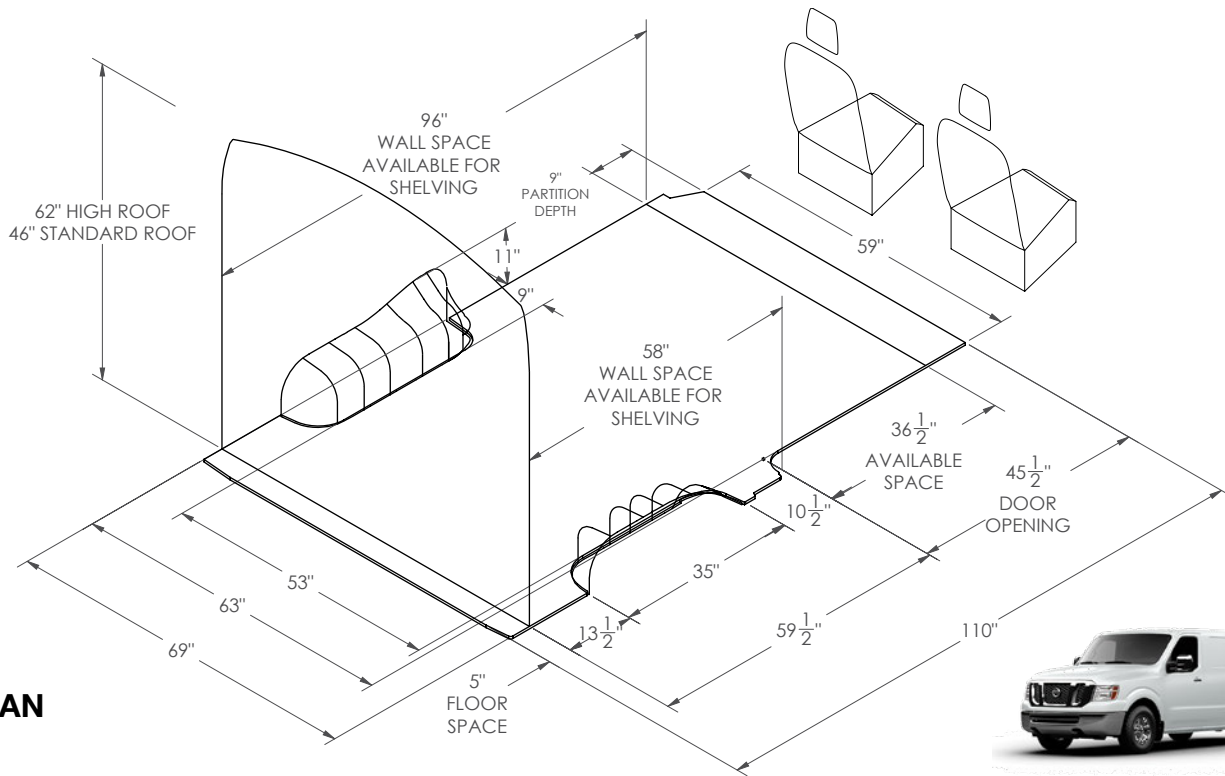

NISSAN NV200

Regular 115" Wheelbase

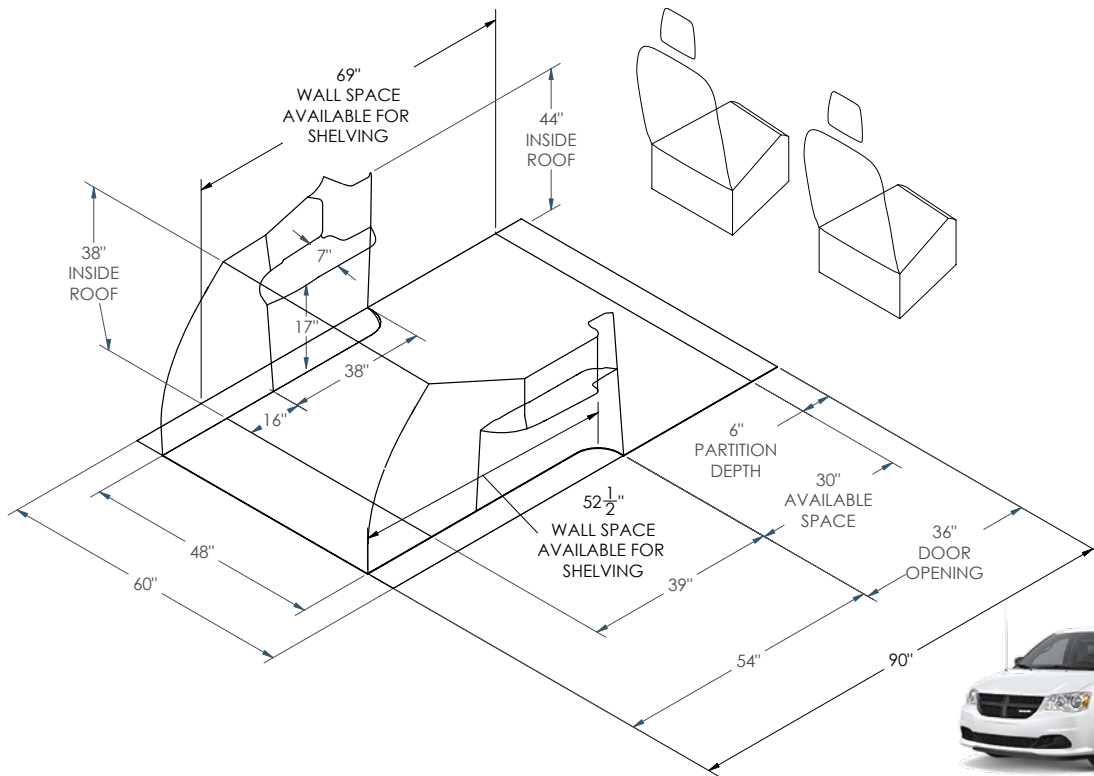

RAM C/V

Regular 121" Wheelbase

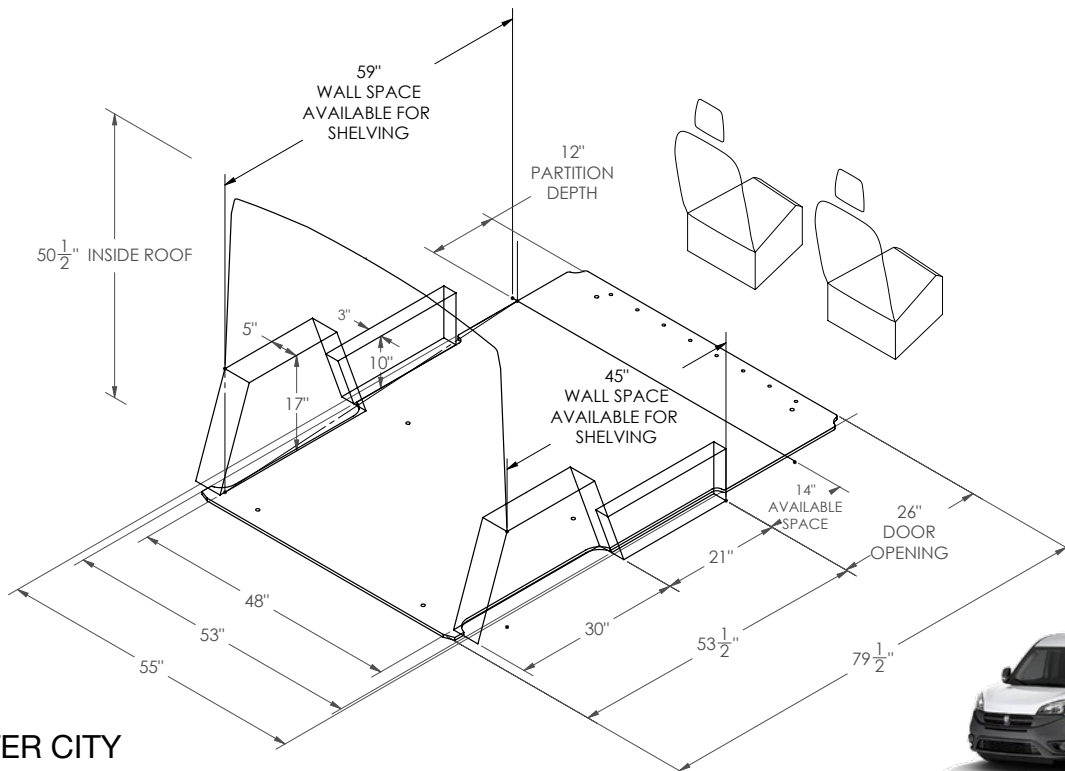

RAM PROMASTER CITY

Standard 122" Wheelbase

LAYOUT GUIDES

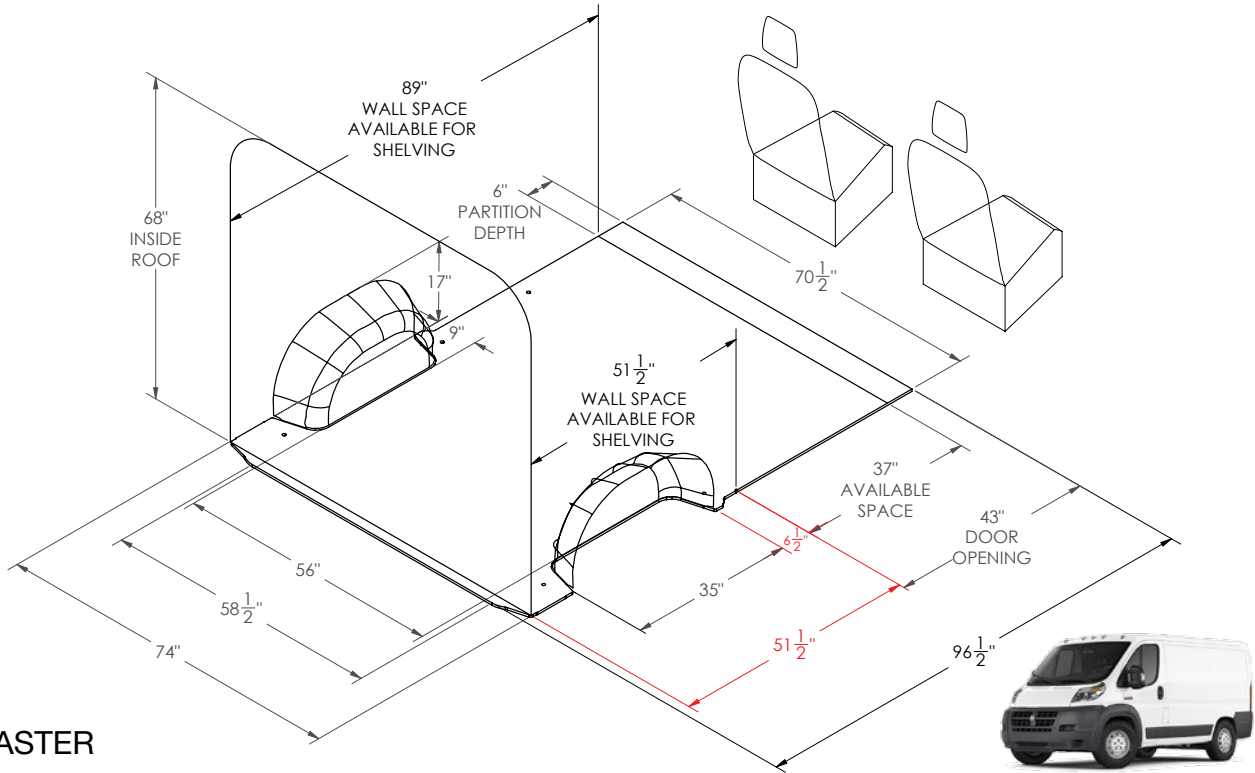

RAM PROMASTER

Short 118" Wheelbase

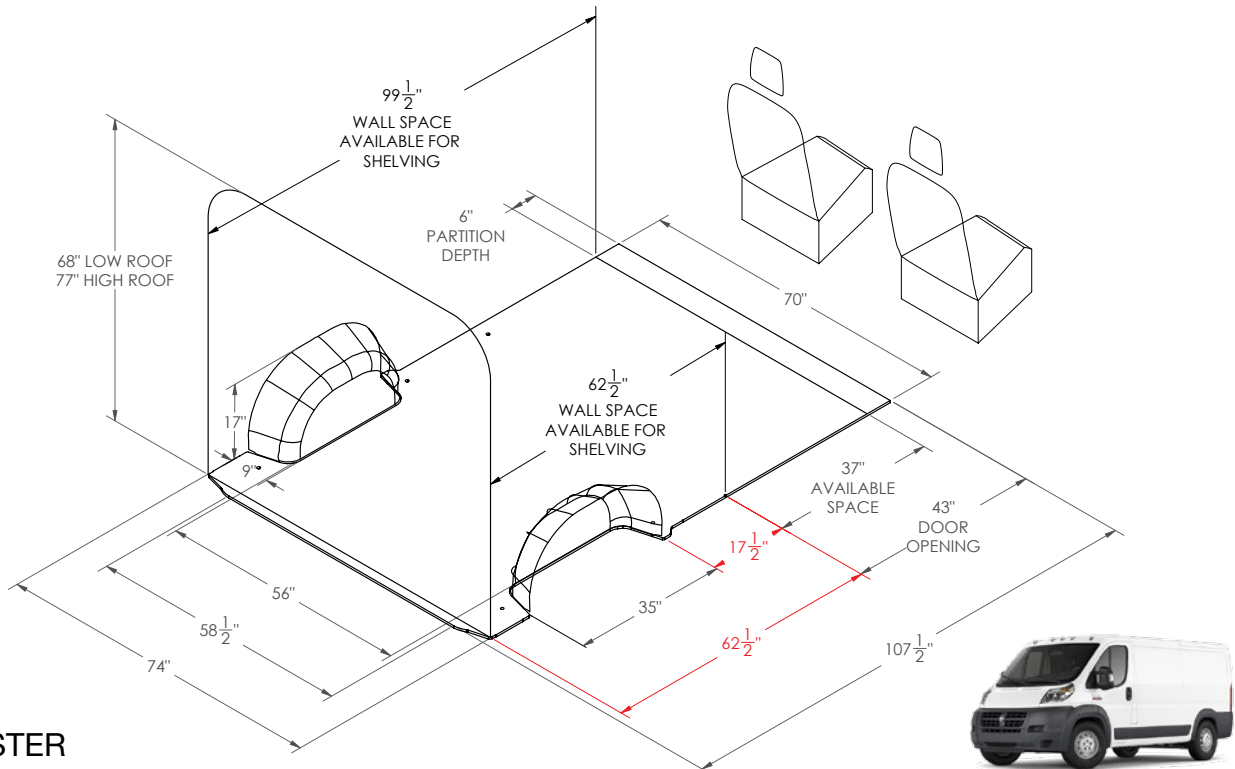

RAM PROMASTER

Medium 136" Wheelbase

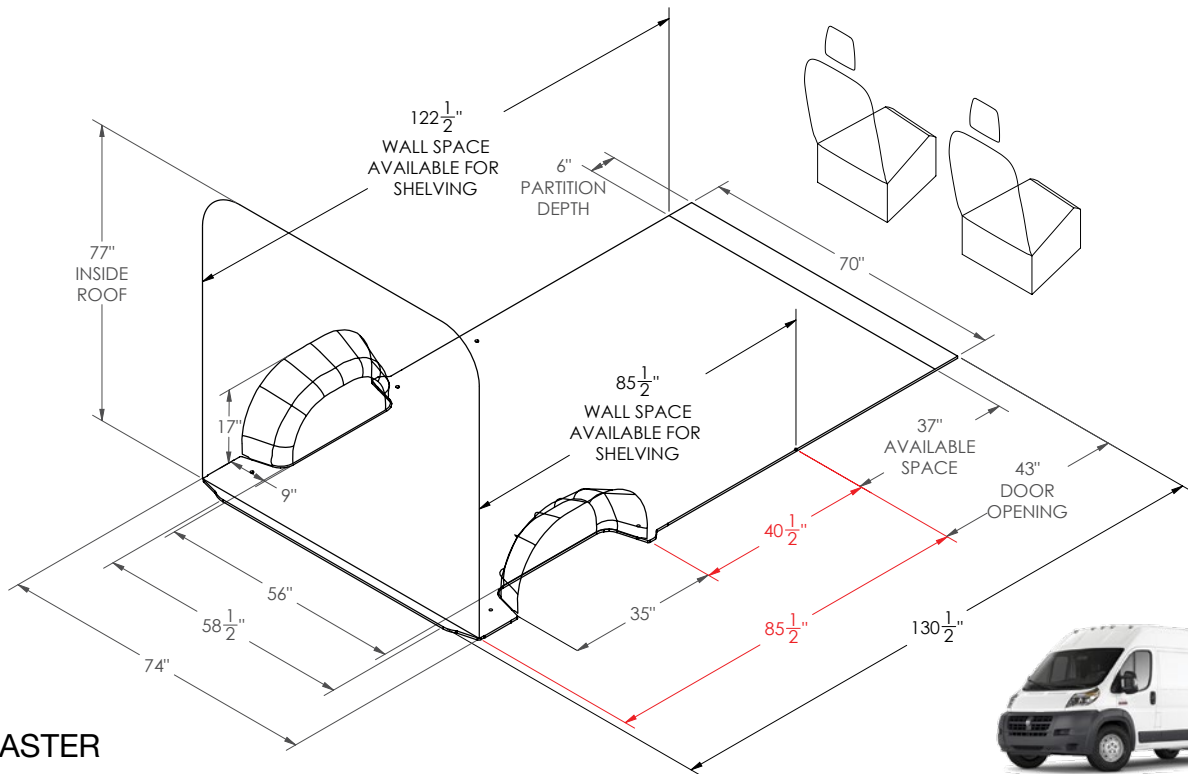

RAM PROMASTER
Long 159" Wheelbase

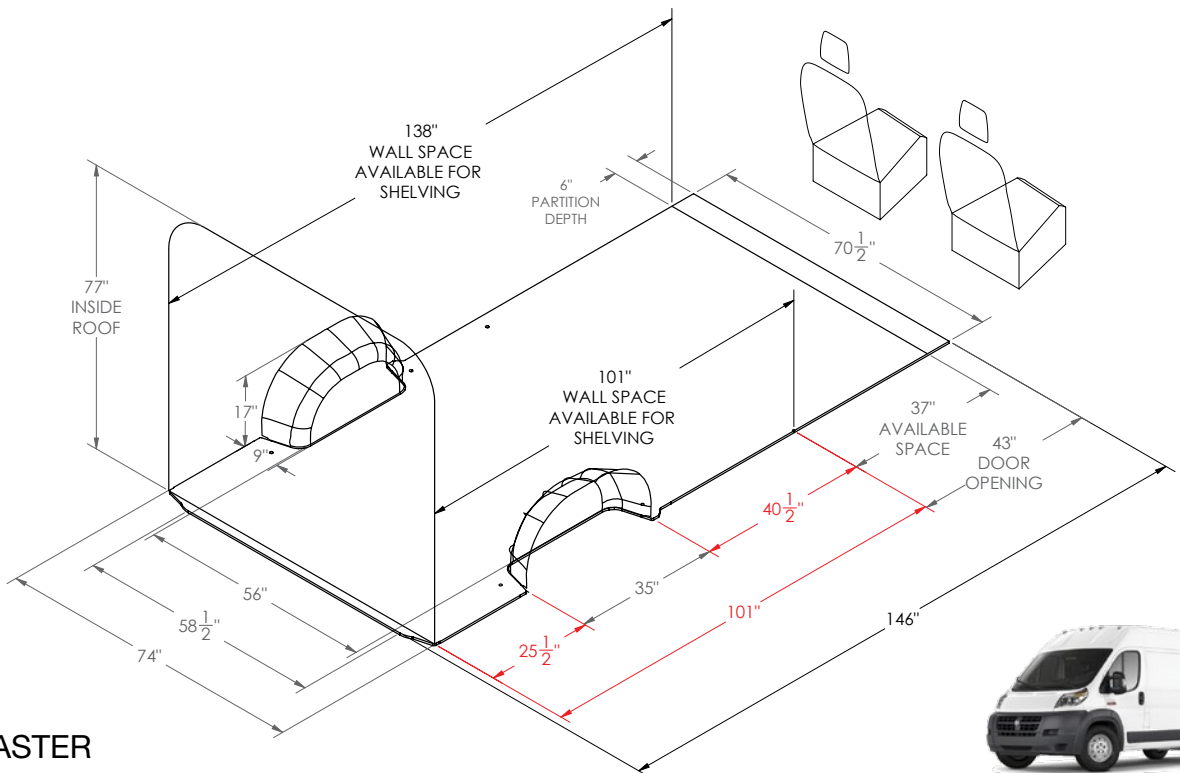

RAM PROMASTER
Extended 159" Wheelbase





SHELVING

Industry leading strength.
The perfect fit for the toughest jobs.



TOUGH
Extrusion builds durability into shelf.

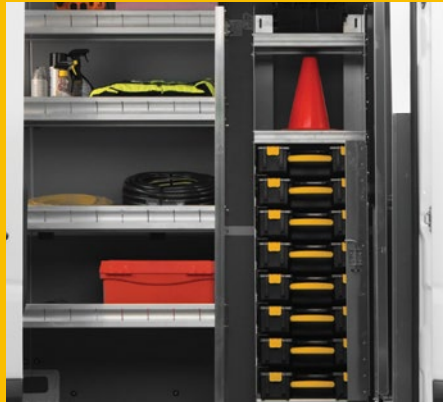

QUIET
Shelf tray, end panel and extrusion are engineered to be vibration free.



ORGANIZED
A well-Planned van outfit increases productivity.

SHELVING

BOOKSHELVES..... P. 26

CONTOURED UNITS

CONTOURED BIN SHELVING UNIT P. 26

CONTOURED REFRIGERANT BIN UNIT P. 31

CONTOURED SHELVING UNIT P. 33

CONTOURED SHELVING UNIT W/ DIVIDERS P. 35

DEEP SQUARE BACK UNITS

DEEP SQ. BACK BIN SHELVING UNIT P. 45

DEEP SQ. BACK SHELVING UNIT P. 45

DEEP SQ. BACK SHELVING UNIT W/ DIVIDERS . . P. 46

FOLD-AWAY SHELVING..... P. 47

SQUARE BACK UNITS

SQUARE BACK BIN SHELVING UNIT P. 49

SQUARE BACK SHELVING UNIT P. 51

SQUARE BACK SHELVING UNIT W/ DIVIDERS . . P. 53

DOORS P. 57

LOCKERS P. 58

WORKBENCHES..... P. 58











Ranger Design shelving is built strong and durable and often outlasts the vehicle. Designed to fit with maximum efficiency, Ranger shelving optimizes the space in a work van's cargo area.



Application Guide



Type	Material	Box Truck & Trailer	Chevrolet City Express	Chevrolet Express	Ford E-Series	Ford Transit Low Roof	Ford Transit Medium Roof	Ford Transit High Roof	Ford Transit Connect
Bookshelf	Aluminum	71 p. 26		71 p. 26	71 p. 26	71 p. 26	71 p. 26	71 p. 26	
Contoured Bin Shelving Unit	Aluminum		BD p. 28	52 p. 26 96 p. 27	52 p. 26 96 p. 27	BB p. 27	BC p. 28	BC p. 28	BE p. 28
Contoured Bin Shelving Unit	Steel		HW p. 31	HA p. 29	HA p. 29				HE p. 30 HF p. 30
Contoured Refrigerant Bin Unit	Aluminum		RD p. 32	54 p. 31	54 p. 31	RB p. 32	RC p. 32	RC p. 32	
Contoured Shelving Unit	Steel		LW p. 35	LA p. 33	LA p. 33				LE p. 34 LF p. 34
Contoured Shelving Unit with Dividers	Aluminum		SD p. 43	40 p. 35 95 p. 38	40 p. 35 95 p. 38	SB p. 41	SC p. 42	SC p. 42	SE p. 43 SF p. 43
Contoured Shelving Unit with Dividers	Steel		FW p. 40	FA p. 39	FA p. 39				FE p. 39 FF p. 40
Deep Square Back Bin Shelving Unit	Steel	HT p. 45					HT p. 45	HT p. 45	
Deep Square Back Shelving Unit	Steel	LT p. 45					LT p. 45	LT p. 45	
Deep Square Back Shelving Unit with Dividers	Steel	FT p. 46					FT p. 46	FT p. 46	
Fold-Away Shelf Tray with Gas Shocks and Hardware	Aluminum	84 p. 47	84 p. 47	84 p. 47	84 p. 47	84 p. 47	84 p. 47	84 p. 47	84 p. 47
Fold-Away Shelving	Aluminum	84 p. 47	83 p. 47	85 p. 48	85 p. 48	85 p. 48	84 p. 47	84 p. 47	83 p. 47
Mounting Bar Assembly for Fold-Away Shelving	Aluminum	84 p. 48	84 p. 48	84 p. 48	84 p. 48	84 p. 48	84 p. 48	84 p. 48	84 p. 48
Post Assembly for Fold-Away Shelving	Aluminum	84 p. 49	84 p. 49	84 p. 49	84 p. 49	84 p. 49	84 p. 49	84 p. 49	84 p. 49
Square Back Bin Shelving Unit	Aluminum	73 p. 49 78 p. 49 91 p. 50	78 p. 49	78 p. 49	78 p. 49	78 p. 49	78 p. 49	78 p. 49	78 p. 49
Square Back Bin Shelving Unit	Steel	HX p. 51				HR p. 50	HX p. 51	HX p. 51	
Square Back Shelving Unit	Steel	LX p. 52				LR p. 52	LX p. 52	LX p. 52	
Square Back Shelving Unit with Dividers	Aluminum	48 p. 53 90 p. 54							
Square Back Shelving Unit with Dividers	Steel	FX p. 56				FR p. 56	FX p. 56	FX p. 56	

										
GMC Savana	Mercedes-Benz Metris	Mercedes-Benz Sprinter Low Roof	Mercedes-Benz Sprinter High Roof	Nissan NV Low Roof	Nissan NV High Roof	Nissan NV200	Ram C/V	Ram ProMaster	Ram ProMaster High Roof	Ram ProMaster City
71 p. 26		71 p. 26	71 p. 26	71 p. 26	71 p. 26		71 p. 26	71 p. 26	71 p. 26	
52 p. 26 96 p. 27	BL p. 29	79 p. 26	79 p. 26 89 p. 27	BB p. 27	BC p. 28	BD p. 28		BC p. 28	BC p. 28	BH p. 29
HA p. 29	HL p. 30					HW p. 31				HH p. 30
54 p. 31	RL p. 33	57 p. 31	57 p. 31 87 p. 32	RB p. 32	RC p. 32	RD p. 32		RC p. 32	RC p. 32	RH p. 33
LA p. 33	LL					LW p. 35				LH p. 34
40 p. 35 95 p. 38	SL p. 44	41 p. 36	41 p. 36 88 p. 37	SB p. 41	SC p. 42	SD p. 43		SC p. 42	SC p. 42	SH p. 44
FA p. 39	FL p. 40					FW p. 40				FH p. 40
		HT p. 45	HT p. 45		HT p. 45			HT p. 45	HT p. 45	
		LT p. 45	LT p. 45		LT p. 45			LT p. 45	LT p. 45	
		FT p. 46	FT p. 46		FT p. 46			FT p. 46	FT p. 46	
84 p. 47	84 p. 47	84 p. 47	84 p. 47	84 p. 47	84 p. 47	84 p. 47	84 p. 47	84 p. 47	84 p. 47	84 p. 47
85 p. 48	86 p. 48	84 p. 47	84 p. 47	85 p. 48	84 p. 47	83 p. 47		84 p. 47	84 p. 47	83 p. 47
84 p. 48	84 p. 48	84 p. 48	84 p. 48	84 p. 48	84 p. 48	84 p. 48	84 p. 48	84 p. 48	84 p. 48	84 p. 48
84 p. 49	84 p. 49	84 p. 49	84 p. 49	84 p. 49	84 p. 49	84 p. 49	84 p. 49	84 p. 49	84 p. 49	84 p. 49
78 p. 49	78 p. 49	78 p. 49	78 p. 49	78 p. 49	78 p. 49	78 p. 49	51 p. 49 78 p. 49	78 p. 49	78 p. 49	78 p. 49
		HX p. 51	HX p. 51	HR p. 50	HX p. 51		HG p. 50	HX p. 51	HX p. 51	
		LX p. 52	LX p. 52	LR p. 52	LX p. 52		LG p. 51	LX p. 52	LX p. 52	
							43 p. 53 45 p. 53			
		FX p. 56	FX p. 56	FR p. 56	FX p. 56		FG p. 55	FX p. 56	FX p. 56	

SHELVING – BOOKSHELF

Bookshelf

Aluminum



Box Truck	Transit High Roof	Transit Medium Roof	Sprinter High Roof	Sprinter Low Roof	NV High Roof	ProMaster High Roof	ProMaster
7108	14" D x 9" W x 62.5" H	30 lbs	12.5"			0.5 hr	Yes



Bookshelf

Aluminum



Express	E-Series	Transit Low Roof	Savana	NV Low Roof			
7109	14" D x 9" W x 43" H	18 lbs	12.5"			0.4 hr	No



Contoured Bin Shelving Unit

Aluminum



Express	E-Series	Savana					
5236	12.5" D x 36" W x 43" H	49 lbs			18(sm), 18(md)	1 hr	No
5248	12.5" D x 48" W x 43" H	61 lbs			24(sm), 24(md)	1 hr	No
5260	12.5" D x 60" W x 43" H	75 lbs			30(sm), 30(md)	1 hr	No

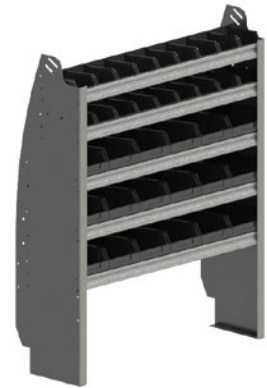

Contoured Bin Shelving Unit

Aluminum



Sprinter High Roof	Sprinter Low Roof						
7936	15.5" D x 36" W x 62.5" H	99 lbs			18(sm), 18(md), 8(lrg)	1.4 hrs	No
7948	15.5" D x 48" W x 62.5" H	123 lbs			24(sm), 24(md), 12(lrg)	1.4 hrs	Yes
7960	15.5" D x 60" W x 62.5" H	143 lbs			30(sm), 30(md), 14(lrg)	1.4 hrs	No



SHELVING – CONTOURED BIN SHELVING UNIT

Contoured Bin Shelving Unit

Aluminum



Sprinter
High Roof



8936-7	15.5" D x 36" W x 72" H	100 lbs			18(sm), 18(md), 8(lrg)	1.4 hrs	No
8948-7	15.5" D x 48" W x 72" H	124 lbs			24(sm), 24(md), 12(lrg)	1.4 hrs	No
8960-7	15.5" D x 60" W x 72" H	144 lbs			30(sm), 30(md), 14(lrg)	1.4 hrs	No

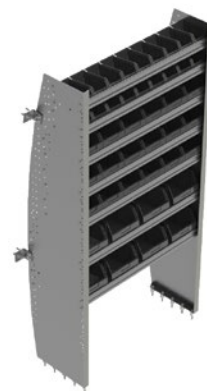

Contoured Bin Shelving Unit

Aluminum



Sprinter
High Roof



8936-8	15.5" D x 36" W x 72" H	112 lbs			18(sm), 18(md), 12(lrg)	1.4 hrs	No
8948-8	15.5" D x 48" W x 72" H	140 lbs			24(sm), 24(md), 18(lrg)	1.4 hrs	No
8960-8	15.5" D x 60" W x 72" H	164 lbs			30(sm), 30(md), 21(lrg)	1.4 hrs	No

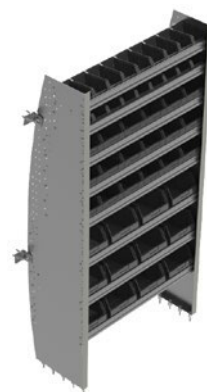

Contoured Bin Shelving Unit

Aluminum



Express



E-Series



Savana



9636	16.5" D x 36" W x 43" H	53 lbs			12(md), 8(lrg)	1 hr	No
9648	16.5" D x 48" W x 43" H	67 lbs			16(md), 12(lrg)	1 hr	Yes
9660	16.5" D x 60" W x 43" H	79 lbs			20(md), 14(lrg)	1 hr	No



Contoured Bin Shelving Unit

Aluminum



Transit
Low Roof



NV
Low Roof



BB36	15" D x 36" W x 46" H	63 lbs			6 (md), 12 (lrg)	1 hr	No
BB48	15" D x 48" W x 46" H	81 lbs			8 (md), 18 (lrg)	1 hr	Yes
BB60	15" D x 60" W x 46" H	96 lbs			10 (md), 21 (lrg)	1 hr	No



SHELVING – CONTOURED BIN SHELVING UNIT

Contoured Bin Shelving Unit

Aluminum



Transit High Roof

Transit Medium Roof

NV High Roof

ProMaster High Roof

ProMaster

Does not fit over wheel well in ProMaster.



BC36	15.5" D x 36" W x 62.5" H	82 lbs	6 Shelves (9", 9", 9", 13", 13", 13")	18 (md), 12 (lrg)	1.4 hrs	No
BC48	15.5" D x 48" W x 62.5" H	104 lbs	6 Shelves (9", 9", 9", 13", 13", 13")	24 (md), 18 (lrg)	1.4 hrs	Yes
BC60	15.5" D x 60" W x 62.5" H	123 lbs	6 Shelves (9", 9", 9", 13", 13", 13")	30 (md), 21 (lrg)	1.4 hrs	No



Contoured Bin Shelving Unit

Aluminum



Transit High Roof

Transit Medium Roof

NV High Roof

ProMaster High Roof

ProMaster



BC36-5	15.5" D x 36" W x 62.5" H	71 lbs	5 Shelves (9.5", 9.5", 9.5", 13", 13")	18 (md), 8 (lrg)	1.4 hrs	No
BC48-5	15.5" D x 48" W x 62.5" H	89 lbs	5 Shelves (9.5", 9.5", 9.5", 13", 13")	24 (md), 12 (lrg)	1.4 hrs	No
BC60-5	15.5" D x 60" W x 62.5" H	104 lbs	5 Shelves (9.5", 9.5", 9.5", 13", 13")	30 (md), 14 (lrg)	1.4 hrs	No



Contoured Bin Shelving Unit

Aluminum



City Express

NV200



BD36	14" D x 36" W x 40" H	49 lbs		18(sm), 18(md)	1 hr	Yes
-------------	-----------------------	--------	--	----------------	------	-----



Contoured Bin Shelving Unit

Aluminum



Transit Connect



BE36	12.5" D x 36" W x 44" H	49 lbs		27 (sm), 12 (md)	1 hr	Yes
-------------	-------------------------	--------	--	------------------	------	-----



SHELVING – CONTOURED BIN SHELVING UNIT

Contoured Bin Shelving Unit

Aluminum



ProMaster
City



	Dimensions	Weight	Shelf Opening	Dividers	Bins	Estimated Install Time	Quickship
BH36	15" D x 36" W x 45" H	64 lbs			18 (sm), 18 (md)	1 hr	Yes
BH48	15" D x 48" W x 45" H	81 lbs			24 (sm), 24 (md)	1 hr	No
BH60	15" D x 60" W x 45" H	97 lbs			30 (sm), 30 (md)	1 hr	No



Contoured Bin Shelving Unit

Aluminum



Metris



	Dimensions	Weight	Shelf Opening	Dividers	Bins	Estimated Install Time	Quickship
BL36	14" D x 36" W x 46" H	62 lbs			24 (md)	1 hr	Yes
BL48	14" D x 48" W x 46" H	76 lbs			32 (md)	1 hr	No
BL60	14" D x 60" W x 46" H	91 lbs			40 (md)	1 hr	No



Contoured Bin Shelving Unit

Steel



Express



E-Series



Savana



	Dimensions	Weight	Shelf Opening	Dividers	Bins	Estimated Install Time	Quickship
H38-A	15" D x 38" W x 46" H	63 lbs	3 Shelves (9", 12", 13")	6	6	1 hr	No
H42-A	15" D x 42" W x 46" H	68 lbs	3 Shelves (9", 12", 13")	6	7	1 hr	No
H56-A	15" D x 56" W x 46" H	81 lbs	3 Shelves (9", 12", 13")	8	9	1 hr	No
H70-A	15" D x 70" W x 46" H	95 lbs	3 Shelves (9", 12", 13")	8	11	1 hr	No

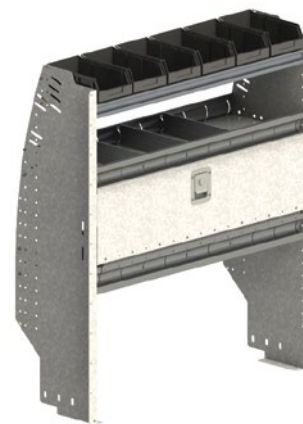

Contoured Bin Shelving Unit

Steel



Express



E-Series



Savana



	Dimensions	Weight	Shelf Opening	Dividers	Bins	Estimated Install Time	Quickship
H87-A	15" D x 87" W x 46" H	116 lbs	3 Shelves (9", 12", 13")	12	14	1 hr	No

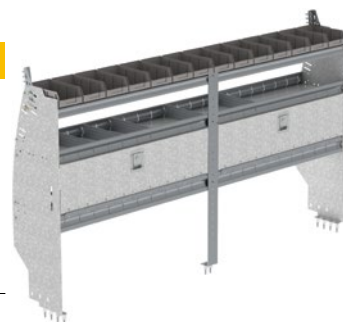

SHELVING – CONTOURED BIN SHELVING UNIT

Contoured Bin Shelving Unit

Steel



Transit
Connect



H36-E 12.5" D x 36" W x 44" H 60 lbs

1 hr Yes

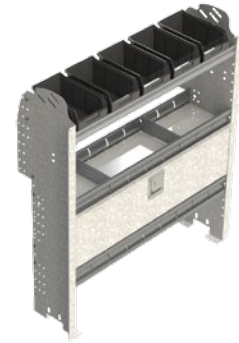

Contoured Bin Shelving Unit

Steel



Transit
Connect



H36-F 17.5" D x 36" W x 44" H 63 lbs

1 hr Yes

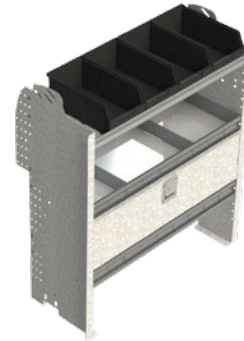

Contoured Bin Shelving Unit

Steel



ProMaster
City



H36-H 15" D x 36" W x 45" H 54 lbs

1 hr Yes



Contoured Bin Shelving Unit

Steel



Metris



H36-L 14" D x 36" W x 46" H 58 lbs

3 Shelves (11", 13", 13")

4

6 (md)

1 hr

No

H48-L 14" D x 48" W x 46" H 68 lbs

3 Shelves (11", 13", 13")

6

8 (md)

1 hr

No

H60-L 14" D x 60" W x 46" H 79 lbs

3 Shelves (11", 13", 13")

8

10 (md)

1 hr

No

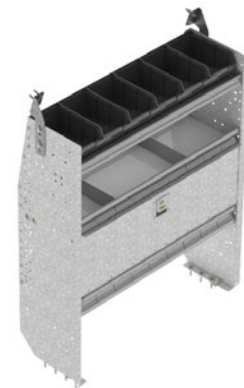

SHELVING – CONTOURED BIN SHELVING UNIT

Contoured Bin Shelving Unit

Steel



Metris



H72-L	14" D x 72" W x 46" H	91 lbs	3 Shelves (11", 13", 13")	12	12 (md)	1 hr	No
--------------	-----------------------	--------	---------------------------	----	---------	------	----



Contoured Bin Shelving Unit

Steel



City Express



NV200



H32-W	14" D x 32" W x 46" H	58 lbs	3 Shelves (9", 12", 13")	6	5 (md)	1 hr	Yes
--------------	-----------------------	--------	--------------------------	---	--------	------	-----



Contoured Refrigerant Bin Unit

Aluminum



Express



E-Series



Savana



5448	12.5" D x 48" W x 43" H	42 lbs		4	24(sm)	1 hr	No
-------------	-------------------------	--------	--	---	--------	------	----

5460	12.5" D x 60" W x 43" H	50 lbs		5	30(sm)	1 hr	No
-------------	-------------------------	--------	--	---	--------	------	----



Contoured Refrigerant Bin Unit

Aluminum



Sprinter High Roof



Sprinter Low Roof



5748	16" D x 48" W x 62.5" H	106 lbs		4	24(sm), 24(md)	1.2 hrs	No
-------------	-------------------------	---------	--	---	----------------	---------	----

5760	16" D x 60" W x 62.5" H	120 lbs		5	30(sm), 30(md)	1.2 hrs	No
-------------	-------------------------	---------	--	---	----------------	---------	----



SHELVING – CONTOURED REFRIGERANT BIN UNIT

Contoured Refrigerant Bin Unit

Aluminum



Sprinter
High Roof



8748	15.5" D x 48" W x 72" H	107 lbs		4	24(sm), 24(md)	1.4 hrs	No
8760	15.5" D x 60" W x 72" H	121 lbs		5	30(sm), 30(md)	1.4 hrs	No



Contoured Refrigerant Bin Unit

Aluminum



Transit
Low Roof



NV
Low Roof



RB48	15" D x 48" W x 46" H	38 lbs	2 Shelves (9", 13.5")	4	8(md)	1 hr	Yes
RB60	15" D x 60" W x 46" H	45 lbs	2 Shelves (9", 13.5")	5	10(md)	1 hr	No



Contoured Refrigerant Bin Unit

Aluminum



Transit
High Roof



Transit
Medium
Roof



NV
High Roof



ProMaster
High Roof



ProMaster



RC48	15.5" D x 48" W x 62.5" H	106 lbs	4 Shelves (9", 9", 9", 12.5")	4	24(md)	1.2 hrs	Yes
RC60	15.5" D x 60" W x 62.5" H	120 lbs	4 Shelves (9", 9", 9", 12.5")	5	30(md)	1.2 hrs	Yes



Contoured Refrigerant Bin Unit

Aluminum



City Express



NV200



RD36	13.75" D x 36" W x 40" H	28 lbs		3	18(sm)	1.3 hrs	No
-------------	--------------------------	--------	--	---	--------	---------	----



SHELVING

SHELVING – CONTOURED REFRIGERANT BIN UNIT

Contoured Refrigerant Bin Unit

Aluminum



ProMaster
City



	Dimensions	Weight	Shelf Opening	Dividers	Bins	Estimated Install Time	Quickship
RH36	15" D x 36" W x 45" H	43 lbs			9(sm), 6(lrg)	1 hr	Yes
RH48	15" D x 48" W x 45" H	52 lbs			12(sm), 8(lrg)	1 hr	No
RH60	15" D x 60" W x 45" H	62 lbs			15(sm), 10(lrg)	1 hr	No



Contoured Refrigerant Bin Unit

Aluminum



Metris



	Dimensions	Weight	Shelf Opening	Dividers	Bins	Estimated Install Time	Quickship
RL36	14" D x 36" W x 46" H	38 lbs			6 (md)	1 hr	Yes



Contoured Shelving Unit

Steel



Express



E-Series



Savana



	Dimensions	Weight	Shelf Opening	Dividers	Bins	Estimated Install Time	Quickship
L38-A	14" D x 38" W x 46" H	61 lbs		4 Shelves (9", 12", 13", 13")		1 hr	No
L42-A	14" D x 42" W x 46" H	65 lbs		4 Shelves (9", 12", 13", 13")		1 hr	No
L56-A	14" D x 56" W x 46" H	78 lbs		4 Shelves (9", 12", 13", 13")		1 hr	No
L70-A	14" D x 70" W x 46" H	91 lbs		4 Shelves (9", 12", 13", 13")		1 hr	No



Contoured Shelving Unit

Steel



Express



E-Series



Savana



	Dimensions	Weight	Shelf Opening	Dividers	Bins	Estimated Install Time	Quickship
L87-A	14" D x 87" W x 46" H	113 lbs		4 Shelves (9", 12", 13", 13")		1 hr	No



SHELVING – CONTOURED SHELVING UNIT

Contoured Shelving Unit

Steel



Transit
Connect



L36-E	15" D × 36" W × 44" H	60 lbs				1 hr	Yes
--------------	-----------------------	--------	--	--	--	------	-----



Contoured Shelving Unit

Steel



Transit
Connect



L36-F	15" D × 36" W × 44" H	62 lbs				1 hr	Yes
--------------	-----------------------	--------	--	--	--	------	-----

L60-F	15" D × 60" W × 44" H	83 lbs				1 hr	Yes
--------------	-----------------------	--------	--	--	--	------	-----



Contoured Shelving Unit

Steel



ProMaster
City



L36-H	15" D × 36" W × 45" H	48 lbs				1 hr	No
--------------	-----------------------	--------	--	--	--	------	----

L60-H	15" D × 60" W × 45" H	64 lbs				1 hr	No
--------------	-----------------------	--------	--	--	--	------	----



Contoured Shelving Unit

Steel



Metris



L36-L	14" D × 36" W × 46" H	51 lbs	4 Shelves (11", 12", 13", 13")			1 hr	No
--------------	-----------------------	--------	--------------------------------	--	--	------	----

L48-L	14" D × 48" W × 46" H	59 lbs	4 Shelves (11", 12", 13", 13")			1 hr	No
--------------	-----------------------	--------	--------------------------------	--	--	------	----

L60-L	14" D × 60" W × 46" H	66 lbs	4 Shelves (11", 12", 13", 13")			1 hr	No
--------------	-----------------------	--------	--------------------------------	--	--	------	----

L72-L	14" D × 72" W × 46" H	76 lbs	4 Shelves (11", 12", 13", 13")			1 hr	No
--------------	-----------------------	--------	--------------------------------	--	--	------	----



SHELVING – CONTOURED SHELVING UNIT

Contoured Shelving Unit

Steel



City Express



NV200



L32-W	14" D x 32" W x 46" H	55 lbs	4 Shelves (9", 12", 13", 13")			1 hr	Yes
L56-W	14" D x 56" W x 46" H	78 lbs	4 Shelves (9", 12", 13", 13")			1 hr	Yes



Contoured Shelving Unit with Dividers

Aluminum



Express



E-Series



Savana



4036-3	14" D x 36" W x 43" H	36 lbs	3 Shelves (8", 11", 12")	18	7723	0.8 hr	No
4048-3	14" D x 48" W x 43" H	44 lbs	3 Shelves (8", 11", 12")	18	7720	0.8 hr	No
4060-3	14" D x 60" W x 43" H	52 lbs	3 Shelves (8", 11", 12")	24	7722	0.8 hr	No



Contoured Shelving Unit with Dividers

Aluminum



Express



E-Series



Savana



4036-4	14" D x 36" W x 43" H	45 lbs	4 Shelves (8", 10", 11", 12")	24	N/A	0.8 hr	No
4048-4	14" D x 48" W x 43" H	54 lbs	4 Shelves (8", 10", 11", 12")	24	N/A	0.8 hr	No
4060-4	14" D x 60" W x 43" H	64 lbs	4 Shelves (8", 10", 11", 12")	32	N/A	0.8 hr	No



Contoured Shelving Unit with Dividers

Aluminum



Express



E-Series



Savana



4072-3	14" D x 72" W x 43" H	60 lbs	3 Shelves (8", 11", 12")	30	7723	1 hr	No
4084-3	14" D x 84" W x 43" H	68 lbs	3 Shelves (8", 11", 12")	30	N/A	1 hr	No
4096-3	14" D x 96" W x 43" H	78 lbs	3 Shelves (8", 11", 12")	36	7720	1 hr	Yes



SHELVING – CONTOURED SHELVING UNIT WITH DIVIDERS

Contoured Shelving Unit with Dividers

Aluminum



Express

E-Series

Savana



4072-4	14" D x 72" W x 43" H	74 lbs	4 Shelves (8", 10", 11", 12")	40	N/A	1 hr	No
4084-4	14" D x 84" W x 43" H	85 lbs	4 Shelves (8", 10", 11", 12")	40	N/A	1 hr	No
4096-4	14" D x 96" W x 43" H	97 lbs	4 Shelves (8", 10", 11", 12")	48	N/A	1 hr	No



Contoured Shelving Unit with Dividers

Aluminum



Sprinter High Roof

Sprinter Low Roof



4136-4	16" D x 36" W x 62.5" H	46 lbs	4 Shelves (10", 11", 13", 13")	24	7733	1.2 hrs	No
4148-4	16" D x 48" W x 62.5" H	56 lbs	4 Shelves (10", 11", 13", 13")	24	7730	1.2 hrs	No
4160-4	16" D x 60" W x 62.5" H	66 lbs	4 Shelves (10", 11", 13", 13")	32	7732	1.2 hrs	No



Contoured Shelving Unit with Dividers

Aluminum



Sprinter High Roof

Sprinter Low Roof



4136-5	16" D x 36" W x 62.5" H	53 lbs	5 Shelves (10", 11", 13", 13", 13")	30	7728	1.2 hrs	No
4148-5	16" D x 48" W x 62.5" H	65 lbs	5 Shelves (10", 11", 13", 13", 13")	30	7725	1.2 hrs	No
4160-5	16" D x 60" W x 62.5" H	78 lbs	5 Shelves (10", 11", 13", 13", 13")	40	7727	1.2 hrs	No



Contoured Shelving Unit with Dividers

Aluminum



Sprinter High Roof

Sprinter Low Roof



4172-4	16" D x 72" W x 62.5" H	76 lbs	4 Shelves (10", 11", 13", 13")	40	7733	1.4 hrs	No
4184-4	16" D x 84" W x 62.5" H	88 lbs	4 Shelves (10", 11", 13", 13")	40	N/A	1.4 hrs	Yes
4196-4	16" D x 96" W x 62.5" H	98 lbs	4 Shelves (10", 11", 13", 13")	48	7730	1.4 hrs	No



SHELVING – CONTOURED SHELVING UNIT WITH DIVIDERS

Contoured Shelving Unit with Dividers

Aluminum

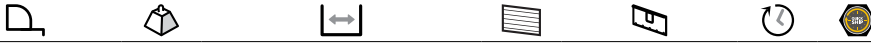

4172-5	16" D x 72" W x 62.5" H	90 lbs	5 Shelves (10", 11", 13", 13", 13")	50	7728	1.4 hrs	No
4184-5	16" D x 84" W x 62.5" H	102 lbs	5 Shelves (10", 11", 13", 13", 13")	50	N/A	1.4 hrs	No
4196-5	16" D x 96" W x 62.5" H	118 lbs	5 Shelves (10", 11", 13", 13", 13")	60	7725	1.4 hrs	No



Contoured Shelving Unit with Dividers

Aluminum



8848-5	15.5" D x 48" W x 72" H	66 lbs	5 Shelves (8", 11", 12", 13", 13")	30	7725	1.3 hrs	No
8860-5	15.5" D x 60" W x 72" H	79 lbs	5 Shelves (8", 11", 12", 13", 13")	40	7727 or 7732	1.3 hrs	No



Contoured Shelving Unit with Dividers

Aluminum



8848-6	15.5" D x 48" W x 72" H	75 lbs	6 Shelves (8", 11", 12", 13", 13", 13")	36	7720	1.3 hrs	No
8860-6	15.5" D x 60" W x 72" H	91 lbs	6 Shelves (8", 11", 12", 13", 13", 13")	48	7722	1.3 hrs	No



Contoured Shelving Unit with Dividers

Aluminum



8872-5	15.5" D x 72" W x 72" H	91 lbs	5 Shelves (8", 11", 12", 13", 13")	40	7728	1.3 hrs	No
8884-5	15.5" D x 84" W x 72" H	103 lbs	5 Shelves (8", 11", 12", 13", 13")	50	N/A	1.3 hrs	No
8896-5	15.5" D x 96" W x 72" H	119 lbs	5 Shelves (8", 11", 12", 13", 13")	60	7725	1.3 hrs	No



SHELVING – CONTOURED SHELVING UNIT WITH DIVIDERS

Contoured Shelving Unit with Dividers

Aluminum



Sprinter
High Roof



8872-6	15.5" D x 72" W x 72" H	105 lbs	6 Shelves (8", 11", 12", 13", 13", 13")	48	7723	1.3 hrs	No
8884-6	15.5" D x 84" W x 72" H	117 lbs	6 Shelves (8", 11", 12", 13", 13", 13")	60	N/A	1.3 hrs	No
8896-6	15.5" D x 96" W x 72" H	139 lbs	6 Shelves (8", 11", 12", 13", 13", 13")	72	7720	1.3 hrs	No



Contoured Shelving Unit with Dividers

Aluminum



Express



E-Series



Savana



9536-3	16.5" D x 36" W x 43" H	44 lbs	3 Shelves (11", 14", 15")	12	7728	1 hr	No
9548-3	16.5" D x 48" W x 43" H	53 lbs	3 Shelves (11", 14", 15")	18	7725	1 hr	No
9560-3	16.5" D x 60" W x 43" H	63 lbs	3 Shelves (11", 14", 15")	24	7727	1 hr	No



Contoured Shelving Unit with Dividers

Aluminum



Express



E-Series



Savana



9536-4	16.5" D x 36" W x 43" H	53 lbs	4 Shelves (11", 13", 14", 15")	16	N/A	1 hr	No
9548-4	16.5" D x 48" W x 43" H	66 lbs	4 Shelves (11", 13", 14", 15")	24	7720	1 hr	No
9560-4	16.5" D x 60" W x 43" H	79 lbs	4 Shelves (11", 13", 14", 15")	32	7722	1 hr	No

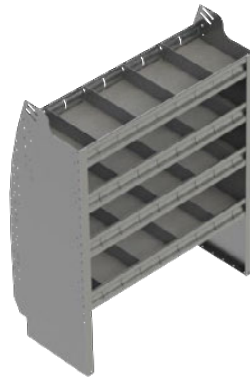

Contoured Shelving Unit with Dividers

Aluminum



Express



E-Series



Savana



9572-3	16.5" D x 72" W x 43" H	76 lbs	3 Shelves (11", 14", 15")	24	7728	1 hr	No
9584-3	16.5" D x 84" W x 43" H	86 lbs	3 Shelves (11", 14", 15")	30	N/A	1 hr	No
9596-3	16.5" D x 96" W x 43" H	95 lbs	3 Shelves (11", 14", 15")	36	7725	1 hr	No



SHELVING – CONTOURED SHELVING UNIT WITH DIVIDERS

Contoured Shelving Unit with Dividers

Aluminum



Express

E-Series

Savana



9572-4	16.5" D x 72" W x 43" H	94 lbs	4 Shelves (11", 13", 14", 15")	32	N/A	1 hr	No
9584-4	16.5" D x 84" W x 43" H	108 lbs	4 Shelves (11", 13", 14", 15")	40	N/A	1 hr	No
9596-4	16.5" D x 96" W x 43" H	120 lbs	4 Shelves (11", 13", 14", 15")	48	7720 x2	1 hr	No

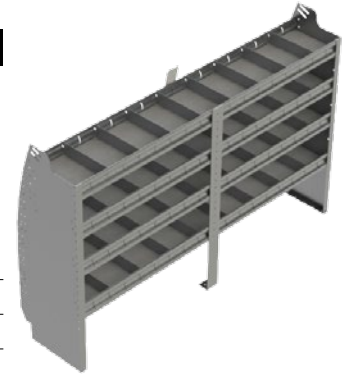

Contoured Shelving Unit with Dividers

Steel



Express

E-Series

Savana



F38-A	15" D x 38" W x 46" H	53 lbs	3 Shelves (9", 12", 13")	6	Y12-D	1 hr	No
F42-A	15" D x 42" W x 46" H	56 lbs	3 Shelves (9", 12", 13")	6	Y12-F	1 hr	Yes
F56-A	15" D x 56" W x 46" H	66 lbs	3 Shelves (9", 12", 13")	8	Y12-J	1 hr	No
F70-A	15" D x 70" W x 46" H	77 lbs	3 Shelves (9", 12", 13")	8	Y12-C	1 hr	No



Contoured Shelving Unit with Dividers

Steel



Express

E-Series

Savana



F87-A	15" D x 87" W x 46" H	95 lbs	3 Shelves (9", 12", 13")	12	Y12-F	1 hr	Yes
--------------	-----------------------	--------	--------------------------	----	-------	------	-----



Contoured Shelving Unit with Dividers

Steel



Transit
Connect



F36-E	12.5" D x 36" W x 44" H	52 lbs	3 Shelves (10", 8", 8")	4	Y11-E	1 hr	Yes
--------------	-------------------------	--------	-------------------------	---	-------	------	-----



SHELVING – CONTOURED SHELVING UNIT WITH DIVIDERS

Contoured Shelving Unit with Dividers

Steel



Transit
Connect



F36-F	17.5" D × 36" W × 44" H	55 lbs	3 Shelves (13", 13", 15")	4	Y11-E	1 hr	Yes
F60-F	17.5" D × 60" W × 44" H	74 lbs	3 Shelves (13", 13", 15")	8	Y12-E	1 hr	Yes



Contoured Shelving Unit with Dividers

Steel



ProMaster
City



F36-H	15" D × 36" W × 45" H	41 lbs	3 Shelves (8", 12", 13")	4	Y11-E	1 hr	Yes
F60-H	15" D × 60" W × 45" H	53 lbs	3 Shelves (8", 12", 13")	8		1 hr	Yes



Contoured Shelving Unit with Dividers

Steel



Metris



F36-L	14" D × 36" W × 46" H	46 lbs	3 Shelves (11", 13", 13")	4	Y10-D	1 hr	Yes
F48-L	14" D × 48" W × 46" H	52 lbs	3 Shelves (11", 13", 13")	6	Y10-H	1 hr	No
F60-L	14" D × 60" W × 46" H	59 lbs	3 Shelves (11", 13", 13")	8	Y10-L	1 hr	No
F72-L	14" D × 72" W × 46" H	67 lbs	3 Shelves (11", 13", 13")	10	Y10-D	1 hr	Yes



Contoured Shelving Unit with Dividers

Steel



City Express



NV200



F32-W	14" D × 32" W × 46" H	48 lbs	3 Shelves (9", 12", 13")	6	Y11-M	1 hr	Yes
F56-W	14" D × 56" W × 46" H	66 lbs	3 Shelves (9", 12", 13")	8	Y11-J	1 hr	Yes



SHELVING – CONTOURED SHELVING UNIT WITH DIVIDERS

Contoured Shelving Unit with Dividers

Aluminum



Transit
Low Roof

NV
Low Roof



SB36-3	15.5" D x 36" W x 46" H	39 lbs	3 Shelves (13", 13", 13")	12	7728	0.8 hr	No
SB48-3	15.5" D x 48" W x 46" H	48 lbs	3 Shelves (13", 13", 13")	18	7725	0.8 hr	Yes
SB60-3	15.5" D x 60" W x 46" H	58 lbs	3 Shelves (13", 13", 13")	21	7727	0.8 hr	Yes



Contoured Shelving Unit with Dividers

Aluminum



Transit
Low Roof

NV
Low Roof



SB36-4	15.5" D x 36" W x 46" H	49 lbs	4 Shelves (13", 13", 13", 13")	16	7723	0.8 hr	No
SB48-4	15.5" D x 48" W x 46" H	62 lbs	4 Shelves (13", 13", 13", 13")	24	7720	0.8 hr	No
SB60-4	15.5" D x 60" W x 46" H	75 lbs	4 Shelves (13", 13", 13", 13")	28	7722	0.8 hr	No



Contoured Shelving Unit with Dividers

Aluminum



Transit
Low Roof

NV
Low Roof



SB72-3	15.5" D x 72" W x 46" H	68 lbs	3 Shelves (13", 13", 13")	24	7728	1 hr	Yes
SB84-3	15.5" D x 84" W x 46" H	78 lbs	3 Shelves (13", 13", 13")	30	N/A	1 hr	No
SB96-3	15.5" D x 96" W x 46" H	87 lbs	3 Shelves (13", 13", 13")	36	7725	1 hr	Yes



Contoured Shelving Unit with Dividers

Aluminum



Transit
Low Roof

NV
Low Roof



SB72-4	15.5" D x 72" W x 46" H	88 lbs	4 Shelves (13", 13", 13", 13")	32	7723	1 hr	No
SB84-4	15.5" D x 84" W x 46" H	101 lbs	4 Shelves (13", 13", 13", 13")	40	N/A	1 hr	No
SB96-4	15.5" D x 96" W x 46" H	114 lbs	4 Shelves (13", 13", 13", 13")	48	7720	1 hr	No



SHELVING – CONTOURED SHELVING UNIT WITH DIVIDERS

Contoured Shelving Unit with Dividers

Aluminum



Transit High Roof Transit Medium Roof NV High Roof ProMaster High Roof ProMaster



SC36-4	15.5" D x 36" W x 62.5" H	46 lbs	4 Shelves (11", 12", 13", 13")	16	7733	1.2 hrs	Yes
SC48-4	15.5" D x 48" W x 62.5" H	56 lbs	4 Shelves (11", 12", 13", 13")	24	7730	1.2 hrs	Yes
SC60-4	15.5" D x 60" W x 62.5" H	66 lbs	4 Shelves (11", 12", 13", 13")	28	7732	1.2 hrs	Yes



Contoured Shelving Unit with Dividers

Aluminum



Transit High Roof Transit Medium Roof NV High Roof ProMaster High Roof ProMaster

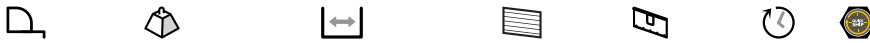

SC36-5	15.5" D x 36" W x 62.5" H	53 lbs	5 Shelves (11", 11", 13", 13", 13")	20	7723	1.2 hrs	No
SC48-5	15.5" D x 48" W x 62.5" H	65 lbs	5 Shelves (11", 11", 13", 13", 13")	30	7720	1.2 hrs	No
SC60-5	15.5" D x 60" W x 62.5" H	78 lbs	5 Shelves (11", 11", 13", 13", 13")	35	7722	1.2 hrs	No



Contoured Shelving Unit with Dividers

Aluminum



Transit High Roof Transit Medium Roof NV High Roof ProMaster High Roof ProMaster



SC72-4	15.5" D x 72" W x 62.5" H	76 lbs	4 Shelves (11", 12", 13", 13")	32	7733	1.4 hrs	Yes
SC84-4	15.5" D x 84" W x 62.5" H	88 lbs	4 Shelves (11", 12", 13", 13")	40	N/A	1.4 hrs	No
SC96-4	15.5" D x 96" W x 62.5" H	98 lbs	4 Shelves (11", 12", 13", 13")	48	7730	1.4 hrs	Yes



SHELVING – CONTOURED SHELVING UNIT WITH DIVIDERS

Contoured Shelving Unit with Dividers

Aluminum



Transit High Roof Transit Medium Roof NV High Roof ProMaster High Roof ProMaster



SC72-5	15.5" D × 72" W × 62.5" H	90 lbs	5 Shelves (11", 11", 13", 13", 13")	40	7723	1.4 hrs	Yes
SC84-5	15.5" D × 84" W × 62.5" H	102 lbs	5 Shelves (11", 11", 13", 13", 13")	50	N/A	1.4 hrs	No
SC96-5	15.5" D × 96" W × 62.5" H	118 lbs	5 Shelves (11", 11", 13", 13", 13")	60	7720	1.4 hrs	No



Contoured Shelving Unit with Dividers

Aluminum



City Express NV200



SD36-3	14" D × 36" W × 40" H	36 lbs	3 Shelves (10", 11", 12")	12	7723	0.8 hr	Yes
SD60-3	14" D × 60" W × 40" H	52 lbs	3 Shelves (10", 11", 12")	24	7727	0.8 hr	Yes



Contoured Shelving Unit with Dividers

Aluminum



Transit Connect



SE36-3	12.5" D × 36" W × 44" H	36 lbs	3 Shelves (8", 11", 10")	12	7728	1 hr	Yes
---------------	-------------------------	--------	--------------------------	----	------	------	-----



Contoured Shelving Unit with Dividers

Aluminum



Transit Connect



SF36-3	17.5" D × 36" W × 44" H	36 lbs	3 Shelves (13", 16", 15")	12	7733	1 hr	Yes
SF60-3	17.5" D × 60" W × 44" H	52 lbs	3 Shelves (13", 16", 15")	21	7732	1 hr	Yes



SHELVING – CONTOURED SHELVING UNIT WITH DIVIDERS

Contoured Shelving Unit with Dividers

Aluminum



ProMaster
City



SH36-3	15" D x 36" W x 45" H	41 lbs	3 shelves (13", 12", 8")	12	7728	1 hr	Yes
SH48-3	15" D x 48" W x 45" H	49 lbs	3 shelves (13", 12", 8")	18	7725	1 hr	No
SH60-3	15" D x 60" W x 45" H	58 lbs	3 shelves (13", 12", 8")	21	7727	1 hr	Yes



Contoured Shelving Unit with Dividers

Aluminum



ProMaster
City



SH36-4	15" D x 36" W x 45" H	50 lbs	4 shelves (13", 13", 12", 8")	16	7723	1 hr	No
SH48-4	15" D x 48" W x 45" H	62 lbs	4 shelves (13", 13", 12", 8")	16	7720	1 hr	No
SH60-4	15" D x 60" W x 45" H	74 lbs	4 shelves (13", 13", 12", 8")	28	7722	1 hr	No



Contoured Shelving Unit with Dividers

Aluminum



Metris

















SL36-3	14" D x 36" W x 46" H	44 lbs	3 shelves (11", 13", 13")	12	7723	1 hr	Yes
SL48-3	14" D x 48" W x 46" H	53 lbs	3 shelves (11", 13", 13")	18	7720	1 hr	No
SL60-3	14" D x 60" W x 46" H	62 lbs	3 shelves (11", 13", 13")	21	7722	1 hr	Yes
SL72-3	14" D x 72" W x 46" H	73 lbs	3 shelves (11", 13", 13")	27	7723	1 hr	Yes



SHELVING – DEEP SQUARE BACK BIN SHELVING UNIT

Deep Square Back Bin Shelving Unit





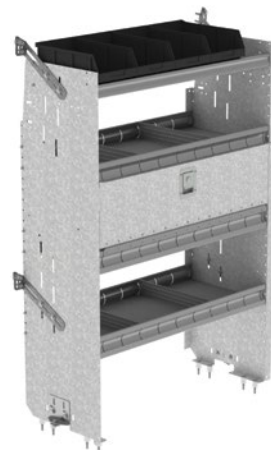









Steel

								
	Box Truck	Transit High Roof	Transit Medium Roof	Sprinter High Roof	Sprinter Low Roof	NV High Roof	ProMaster High Roof	ProMaster
								
H38-T	17" D x 38" W x 58" H	93 lbs	4 Shelves (13", 16", 16", 16")	6	Y11-D	1 hr	No	
H42-T	17" D x 42" W x 58" H	100 lbs	4 Shelves (13", 16", 16", 16")	9	Y11-F	1 hr	No	
H56-T	17" D x 56" W x 58" H	120 lbs	4 Shelves (13", 16", 16", 16")	12	Y11-J	1 hr	No	
H70-T	17" D x 70" W x 58" H	140 lbs	4 Shelves (13", 16", 16", 16")	12	Y11-C	1 hr	No	



Deep Square Back Bin Shelving Unit





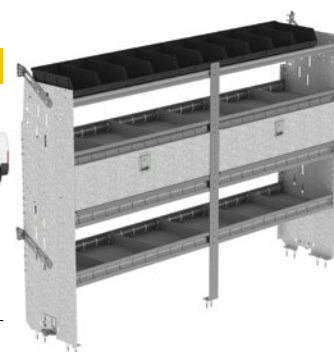









Steel

								
	Box Truck	Transit High Roof	Transit Medium Roof	Sprinter High Roof	Sprinter Low Roof	NV High Roof	ProMaster High Roof	ProMaster
								
H87-T	17" D x 87" W x 58" H	165 lbs	4 Shelves (13", 16", 16", 16")	15	Y11-F	1 hr	No	



Deep Square Back Shelving Unit

Steel

								
	Box Truck	Transit High Roof	Transit Medium Roof	Sprinter High Roof	Sprinter Low Roof	NV High Roof	ProMaster High Roof	ProMaster
								
L38-T	17" D x 38" W x 58" H	88 lbs	5 Shelves (14", 16", 16", 16", 16")			Y10-D	1 hr	No
L42-T	17" D x 42" W x 58" H	93 lbs	5 Shelves (14", 16", 16", 16", 16")			Y10-F	1 hr	No
L56-T	17" D x 56" W x 58" H	112 lbs	5 Shelves (14", 16", 16", 16", 16")			Y10-B	1 hr	No
L70-T	17" D x 70" W x 58" H	130 lbs	5 Shelves (14", 16", 16", 16", 16")			Y10-C	1 hr	No

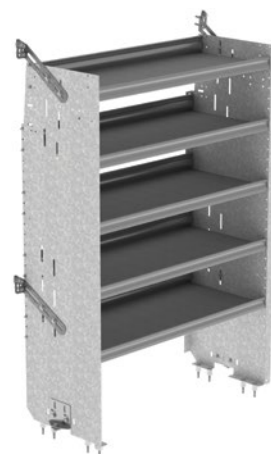

SHELVINGS



SHELVING – DEEP SQUARE BACK SHELVING UNIT

Deep Square Back Shelving Unit

Steel

Box Truck	Transit High Roof	Transit Medium Roof	Sprinter High Roof	Sprinter Low Roof	NV High Roof	ProMaster High Roof	ProMaster
L87-T	17" D x 87" W x 58" H	154 lbs	5 Shelves (14", 16", 16", 16", 16")		Y10-F	1 hr	No



Deep Square Back Shelving Unit with Dividers

Steel

Box Truck	Transit High Roof	Transit Medium Roof	Sprinter High Roof	Sprinter Low Roof	NV High Roof	ProMaster High Roof	ProMaster
F38-T	17.5" D x 38" W x 58" H	80 lbs	4 Shelves (14", 16", 16", 16")	6	Y11-D	1 hr	No
F42-T	17.5" D x 42" W x 58" H	85 lbs	4 Shelves (14", 16", 16", 16")	6	Y11-F	1 hr	No
F56-T	17.5" D x 56" W x 58" H	101 lbs	4 Shelves (14", 16", 16", 16")	12	Y11-J	1 hr	No
F70-T	17.5" D x 70" W x 58" H	115 lbs	4 Shelves (14", 16", 16", 16")	12	Y11-C	1 hr	No

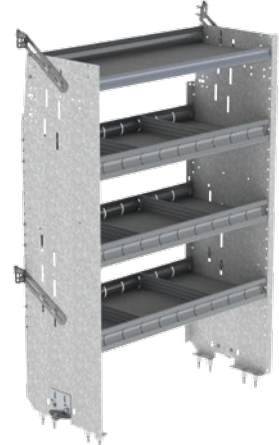

Deep Square Back Shelving Unit with Dividers

Steel

Box Truck	Transit High Roof	Transit Medium Roof	Sprinter High Roof	Sprinter Low Roof	NV High Roof	ProMaster High Roof	ProMaster
F87-T	17.5" D x 87" W x 58" H	136 lbs	4 Shelves (14", 16", 16", 16")	15	Y11-F	1 hr	No

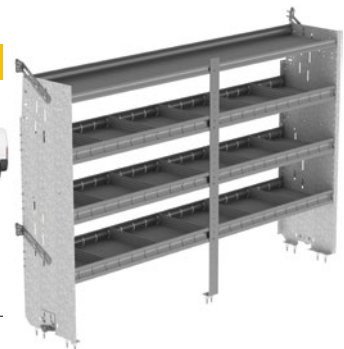







SHELVING

SHELVING – FOLD-AWAY SHELF TRAY WITH GAS SHOCKS AND HARDWARE

Fold-Away Shelf Tray with Gas Shocks and Hardware

Aluminum

							
84-1830	18" D x 30" W	15 lbs	17"			0.4 hr	No
84-1836	18" D x 36" W	17 lbs	17"			0.4 hr	Yes
84-1848	18" D x 48" W	18 lbs	17"			0.4 hr	No
84-1858	18" D x 58" W	21 lbs	17"			0.4 hr	No
84-1872	18" D x 72" W	26 lbs	17"			0.44 hr	Yes
84-2130	21" D x 30" W	16 lbs	20"			0.4 hr	No
84-2136	21" D x 36" W	17 lbs	20"			0.4 hr	Yes
84-2148	21" D x 48" W	20 lbs	20"			0.4 hr	Yes
84-2158	21" D x 58" W	23 lbs	20"			0.43 hr	Yes
84-2172	21" D x 72" W	28 lbs	20"			0.46 hr	Yes







Weight capacity for fold-away shelving is 65 lbs / linear foot.

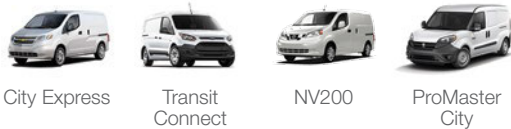

Fold-Away Shelving

Aluminum



							
8330-2	18" D x 37" W x 46.5" H	45 lbs	2 Shelves (17", 17")			1.3 hrs	Yes
8348-2	18" D x 55" W x 46.5" H	52 lbs	2 Shelves (17", 17")			1.31 hrs	No







Weight capacity for fold-away shelving is 65 lbs / linear foot.



Fold-Away Shelving

Aluminum



							
8436-2	21" D x 43" W x 63.5" H	42 lbs	2 Shelves (20", 20")			1.2 hrs	No
8448-2	21" D x 55" W x 63.5" H	58 lbs	2 Shelves (20", 20")			1.2 hrs	Yes
8458-2	21" D x 65" W x 63.5" H	64 lbs	2 Shelves (20", 20")			1.3 hrs	Yes
8472-2	21" D x 79" W x 63.5" H	74 lbs	2 Shelves (20", 20")			1.4 hrs	Yes

Weight capacity for fold-away shelving is 65 lbs / linear foot.



SHELVING – FOLD-AWAY SHELVING

Fold-Away Shelving

Aluminum



	Box Truck	Transit High Roof	Transit Medium Roof	Sprinter High Roof	NV High Roof	ProMaster High Roof	ProMaster Does not fit over wheel well in ProMaster.
8448-3	21" D × 55" W × 72" H	74 lbs	3 Shelves (17", 17", 20")				2.5 hrs No
8458-3	21" D × 65" W × 72" H	83 lbs	3 Shelves (17", 17", 20")				2.7 hrs No
8472-3	21" D × 79" W × 72" H	98 lbs	3 Shelves (17", 17", 20")				2.7 hrs Yes

Weight capacity for fold-away shelving is 65 lbs / linear foot.



Fold-Away Shelving

Aluminum



	Express	E-Series	Transit Low Roof	Savana	NV Low Roof		
8548-2	18" D × 55" W × 53.5" H	52 lbs	2 Shelves (17", 17")				2.2 hrs Yes
8558-2	18" D × 65" W × 53.5" H	59 lbs	2 Shelves (17", 17")				2.4 hrs Yes
8572-2	18" D × 79" W × 53.5" H	70 lbs	2 Shelves (17", 17")				2.4 hrs Yes

Weight capacity for fold-away shelving is 65 lbs / linear foot.



Fold-Away Shelving

Aluminum



Metris

8636-2	18" D × 43" W × 50.5" H	42 lbs	2 Shelves (17", 17")				2.6 hrs Yes
8658-2	18" D × 65" W × 50.5" H	46 lbs	2 Shelves (17", 17")				2.6 hrs Yes

Weight capacity for fold-away shelving is 65 lbs / linear foot.



Mounting Bar Assembly for Fold-Away Shelving

Aluminum



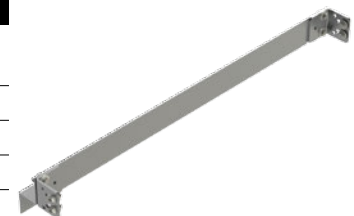



84-3033	2" D × 33" W	3 lbs					0.1 hr No
84-3039	2" D × 39" W	3 lbs					0.1 hr Yes
84-3051	2" D × 51" W	4 lbs					0.11 hr Yes
84-3061	2" D × 61" W	5 lbs					0.12 hr Yes
84-3075	2" D × 75" W	6 lbs					0.14 hr Yes



SHELVING – POST ASSEMBLY FOR FOLD-AWAY SHELVING

Post Assembly for Fold-Away Shelving

Aluminum

							
84-7045	2" D × 2" W × 45.5" H	6 lbs				0.2 hr	No
84-7051	2" D × 2" W × 51.5" H	6 lbs				0.2 hr	Yes
84-7063	2" D × 2" W × 63.5" H	7 lbs				0.2 hr	Yes







Square Back Bin Shelving Unit

Aluminum



C/V

							
5136	10.5" D × 36" W × 32" H	40 lbs			9(sm), 18(md)	1 hr	Yes
5148	10.5" D × 48" W × 32" H	48 lbs			12(sm), 24(md)	1 hr	No
5160	10.5" D × 60" W × 32" H	58 lbs			15(sm), 30(md)	1 hr	No

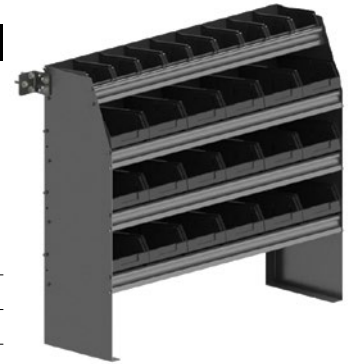







Square Back Bin Shelving Unit

Aluminum









Box Truck

							
7336	15" D × 36" W × 58.5" H	58 lbs			18(sm), 12(md), 8(lrg)	1 hr	No
7348	15" D × 48" W × 58.5" H	70 lbs			24(sm), 16(md), 12(lrg)	1 hr	No
7360	15" D × 60" W × 58.5" H	82 lbs			30(sm), 20(md), 14(lrg)	1 hr	No



Square Back Bin Shelving Unit

Aluminum

							
7848	11" D × 48" W × 13.25" H	25 lbs	2 Shelves (9", 9")		16(md)	0.5 hr	No



SHELVING – SQUARE BACK BIN SHELVING UNIT

Square Back Bin Shelving Unit

Aluminum



Box Truck



9148	13.5" D x 48" W x 62.5" H	103 lbs			56 (md)	1.1 hrs	No
9160	13.5" D x 60" W x 62.5" H	125 lbs			70 (md)	1.1 hrs	No



Square Back Bin Shelving Unit

Steel



C/V



H38-G	14" D x 38" W x 32" H	47 lbs	2 Shelves (13", 13")	3	4	1 hr	No
H42-G	14" D x 42" W x 32" H	51 lbs	2 Shelves (13", 13")	3	5	1 hr	No
H56-G	14" D x 56" W x 32" H	61 lbs	2 Shelves (13", 13")	4	7	1 hr	No
H70-G	14" D x 70" W x 32" H	72 lbs	2 Shelves (13", 13")	4	8	1 hr	No

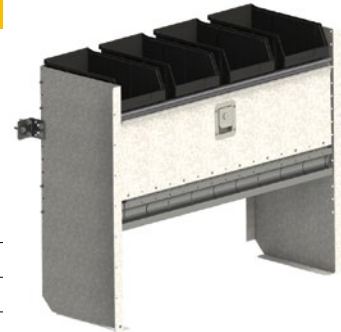

Square Back Bin Shelving Unit

Steel



Transit Low Roof

NV Low Roof



H38-R	14" D x 38" W x 46" H	63 lbs	3 Shelves (13", 13", 13")	6	4	1 hr	No
H42-R	14" D x 42" W x 46" H	68 lbs	3 Shelves (13", 13", 13")	6	5	1 hr	No
H56-R	14" D x 56" W x 46" H	81 lbs	3 Shelves (13", 13", 13")	8	7	1 hr	No
H70-R	14" D x 70" W x 46" H	95 lbs	3 Shelves (13", 13", 13")	8	8	1 hr	No



Square Back Bin Shelving Unit

Steel



Transit Low Roof

NV Low Roof



H87-R	14" D x 87" W x 46" H	116 lbs	3 Shelves (13", 13", 13")	12	10	1 hr	No
--------------	-----------------------	---------	---------------------------	----	----	------	----



SHELVING – SQUARE BACK BIN SHELVING UNIT

Square Back Bin Shelving Unit

Steel



Box Truck Transit High Roof Transit Medium Roof Sprinter High Roof Sprinter Low Roof NV High Roof ProMaster High Roof ProMaster



H38-X	14" D × 38" W × 58" H	80 lbs	4 Shelves (9", 13", 13", 13")	9	6	1 hr	No
H42-X	14" D × 42" W × 58" H	86 lbs	4 Shelves (9", 13", 13", 13")	9	7	1 hr	No
H56-X	14" D × 56" W × 58" H	103 lbs	4 Shelves (9", 13", 13", 13")	12	9	1 hr	No
H70-X	14" D × 70" W × 58" H	120 lbs	4 Shelves (9", 13", 13", 13")	12	11	1 hr	No

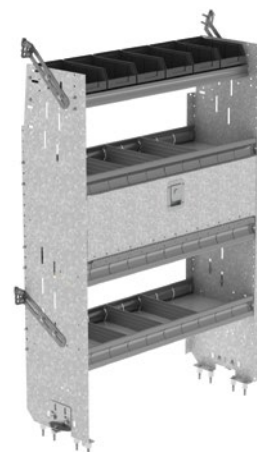

Square Back Bin Shelving Unit

Steel



Box Truck Transit High Roof Transit Medium Roof Sprinter High Roof Sprinter Low Roof NV High Roof ProMaster High Roof ProMaster



H87-X	14" D × 87" W × 58" H	145 lbs	4 Shelves (9", 13", 13", 13")	18	14	1 hr	No
--------------	-----------------------	---------	-------------------------------	----	----	------	----

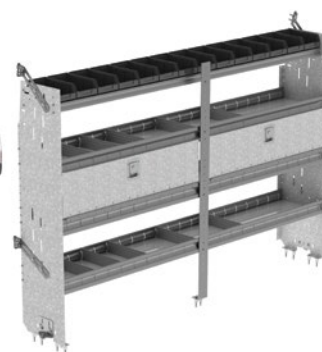

Square Back Shelving Unit

Steel



CV



L38-G	14" D × 38" W × 32" H	46 lbs	3 Shelves (13", 13", 13")			1 hr	Yes
L42-G	14" D × 42" W × 32" H	49 lbs	3 Shelves (13", 13", 13")			1 hr	No
L56-G	14" D × 56" W × 32" H	59 lbs	3 Shelves (13", 13", 13")			1 hr	No
L70-G	14" D × 70" W × 32" H	69 lbs	3 Shelves (13", 13", 13")			1 hr	No



SHELVING – SQUARE BACK SHELVING UNIT

Square Back Shelving Unit

Steel

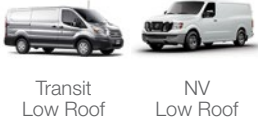

	Icon 1	Icon 2	Icon 3	Icon 4	Icon 5	Icon 6	Icon 7
L38-R	14" D × 38" W × 46" H	61 lbs	4 Shelves (13", 13", 13", 13")	1 hr	No		
L42-R	14" D × 42" W × 46" H	65 lbs	4 Shelves (13", 13", 13", 13")	1 hr	Yes		
L56-R	14" D × 56" W × 46" H	78 lbs	4 Shelves (13", 13", 13", 13")	1 hr	Yes		
L70-R	14" D × 70" W × 46" H	91 lbs	4 Shelves (13", 13", 13", 13")	1 hr	No		



Square Back Shelving Unit

Steel



L87-R	14" D × 87" W × 46" H	113 lbs	4 Shelves (13", 13", 13", 13")	1 hr	No		
--------------	-----------------------	---------	--------------------------------	------	----	--	--



Square Back Shelving Unit

Steel



L38-X	14" D × 38" W × 58" H	78 lbs	5 Shelves (11", 13", 13", 13", 13")	1 hr	Yes		
L42-X	14" D × 42" W × 58" H	82 lbs	5 Shelves (11", 13", 13", 13", 13")	1 hr	Yes		
L56-X	14" D × 56" W × 58" H	99 lbs	5 Shelves (11", 13", 13", 13", 13")	1 hr	Yes		
L70-X	14" D × 70" W × 58" H	115 lbs	5 Shelves (11", 13", 13", 13", 13")	1 hr	No		



Square Back Shelving Unit

Steel



L87-X	14" D × 87" W × 58" H	141 lbs	5 Shelves (11", 13", 13", 13", 13")	1 hr	No		
--------------	-----------------------	---------	-------------------------------------	------	----	--	--



SHELVING

SHELVING – SQUARE BACK SHELVING UNIT WITH DIVIDERS

Square Back Shelving Unit with Dividers

Aluminum



CV



4336-2	13.5" D x 36" W x 29.5" H	28 lbs	2 Shelves (12", 12")	8	7723	0.8 hr	No
4348-2	13.5" D x 48" W x 29.5" H	34 lbs	2 Shelves (12", 12")	12	7720	0.8 hr	Yes
4360-2	13.5" D x 60" W x 29.5" H	40 lbs	2 Shelves (12", 12")	16	7722	0.8 hr	No
4372-2	13.5" D x 72" W x 29.5" H	46 lbs	2 Shelves (12", 12")	16	7723	1 hr	No



Square Back Shelving Unit with Dividers

Aluminum



CV



4536-3	13.5" D x 36" W x 38" H	36 lbs	3 Shelves (12", 12", 12")	18	7723	1 hr	No
4548-3	13.5" D x 48" W x 38" H	44 lbs	3 Shelves (12", 12", 12")	18	7720	1 hr	No
4560-3	13.5" D x 60" W x 38" H	52 lbs	3 Shelves (12", 12", 12")	24	7722	1 hr	No



Square Back Shelving Unit with Dividers

Aluminum



Box Truck



4848-4	16.5" D x 48" W x 62.5" H	68 lbs	4 Shelves (15", 15", 15", 15")	24	7730	1.2 hrs	No
4860-4	16.5" D x 60" W x 62.5" H	80 lbs	4 Shelves (15", 15", 15", 15")	32	7732	1.2 hrs	No



Square Back Shelving Unit with Dividers

Aluminum



Box Truck



4848-5	16.5" D x 48" W x 62.5" H	80 lbs	5 Shelves (15", 15", 15", 15", 15")	30	7720	1.2 hrs	No
4860-5	16.5" D x 60" W x 62.5" H	95 lbs	5 Shelves (15", 15", 15", 15", 15")	40	7722	1.2 hrs	No

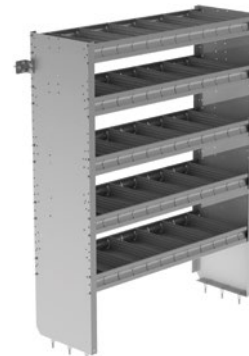

SHELVING – SQUARE BACK SHELVING UNIT WITH DIVIDERS

Square Back Shelving Unit with Dividers

Aluminum



Box Truck



4872-4	16.5" D x 72" W x 62.5" H	90 lbs	4 Shelves (15", 15", 15", 15")	32	7733	1.2 hrs	No
4884-4	16.5" D x 84" W x 62.5" H	116 lbs	4 Shelves (15", 15", 15", 15")		N/A	1.2 hrs	No
4896-4	16.5" D x 96" W x 62.5" H	116 lbs	4 Shelves (15", 15", 15", 15")	48	7730	1.2 hrs	No



Square Back Shelving Unit with Dividers

Aluminum



Box Truck



4872-5	16.5" D x 72" W x 62.5" H	108 lbs	5 Shelves (15", 15", 15", 15", 15")	40	7723	1.2 hrs	No
4884-5	16.5" D x 84" W x 62.5" H	140 lbs	5 Shelves (15", 15", 15", 15", 15")		N/A	1.2 hrs	No
4896-5	16.5" D x 96" W x 62.5" H	140 lbs	5 Shelves (15", 15", 15", 15", 15")	60	7720	1.2 hrs	No



Square Back Shelving Unit with Dividers

Aluminum



Box Truck



9048-4	13.5" D x 48" W x 62.5" H	67 lbs	4 Shelves (12", 12", 12", 12")	24	7730	1.1 hrs	No
9060-4	13.5" D x 60" W x 62.5" H	80 lbs	4 Shelves (12", 12", 12", 12")	32	7732	1.1 hrs	No



Square Back Shelving Unit with Dividers

Aluminum



Box Truck



9048-5	13.5" D x 48" W x 62.5" H	80 lbs	5 Shelves (12", 12", 12", 12", 12")	30	7720	1.1 hrs	No
9060-5	13.5" D x 60" W x 62.5" H	95 lbs	5 Shelves (12", 12", 12", 12", 12")	40	7722	1.1 hrs	No

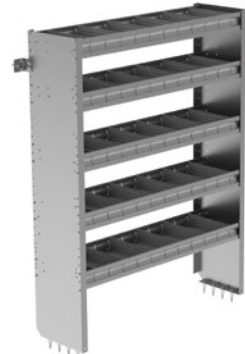

SHELVING – SQUARE BACK SHELVING UNIT WITH DIVIDERS

Square Back Shelving Unit with Dividers

Aluminum



Box Truck



9072-4	13.5" D × 72" W × 62.5" H	92 lbs	4 Shelves (12", 12", 12", 12")	32	7733	1.1 hrs	No
9084-4	13.5" D × 84" W × 62.5" H	105 lbs	4 Shelves (12", 12", 12", 12")	40	N/A	1.1 hrs	No
9096-4	13.5" D × 96" W × 62.5" H	117 lbs	4 Shelves (12", 12", 12", 12")	48	7730	1.1 hrs	No

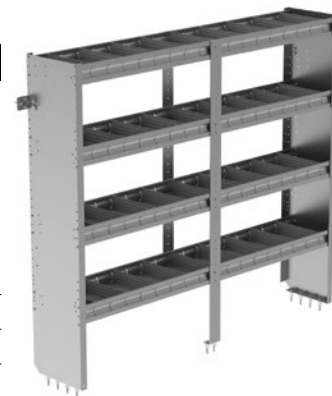

Square Back Shelving Unit with Dividers

Aluminum



Box Truck



9072-5	13.5" D × 72" W × 62.5" H	111 lbs	5 Shelves (12", 12", 12", 12", 12")	40	7723	1.1 hrs	No
9084-5	13.5" D × 84" W × 62.5" H	127 lbs	5 Shelves (12", 12", 12", 12", 12")	50	N/A	1.1 hrs	No
9096-5	13.5" D × 96" W × 62.5" H	142 lbs	5 Shelves (12", 12", 12", 12", 12")	60	7720	1.1 hrs	No

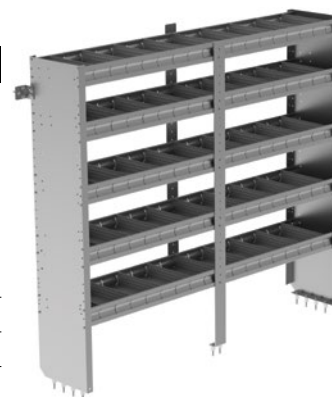

Square Back Shelving Unit with Dividers

Steel



C/V



F38-G	14" D × 38" W × 32" H	38 lbs	2 Shelves (13", 13")	3	Y11-D	1 hr	Yes
F42-G	14" D × 42" W × 32" H	39 lbs	2 Shelves (13", 13")	3	Y11-F	1 hr	No
F56-G	14" D × 56" W × 32" H	46 lbs	2 Shelves (13", 13")	4	Y11-J	1 hr	No
F70-G	14" D × 70" W × 32" H	53 lbs	2 Shelves (13", 13")	4	Y11-C	1 hr	No



SHELVING – SQUARE BACK SHELVING UNIT WITH DIVIDERS

Square Back Shelving Unit with Dividers

Steel



Transit
Low Roof

NV
Low Roof



F38-R	14" D x 38" W x 46" H	63 lbs	3 Shelves (13", 13", 13")	6	Y12-D	1 hr	No
F42-R	14" D x 42" W x 46" H	66 lbs	3 Shelves (13", 13", 13")	6	Y12-F	1 hr	No
F56-R	14" D x 56" W x 46" H	81 lbs	3 Shelves (13", 13", 13")	8	Y12-J	1 hr	No
F70-R	14" D x 70" W x 46" H	94 lbs	3 Shelves (13", 13", 13")	8	Y12-C	1 hr	No



Square Back Shelving Unit with Dividers

Steel



Transit
Low Roof

NV
Low Roof



F87-R	14" D x 87" W x 46" H	118 lbs	3 Shelves (13", 13", 13")	12	Y12-F	1 hr	Yes
--------------	-----------------------	---------	---------------------------	----	-------	------	-----



Square Back Shelving Unit with Dividers

Steel



Box Truck

Transit
High Roof

Transit
Medium
Roof

Sprinter
High Roof

Sprinter
Low Roof

NV
High Roof

ProMaster
High Roof

ProMaster



F38-X	14" D x 38" W x 58" H	70 lbs	4 Shelves (9", 13", 13", 13")	9	Y12-D	1 hr	No
F42-X	14" D x 42" W x 58" H	74 lbs	4 Shelves (9", 13", 13", 13")	9	Y12-F	1 hr	Yes
F56-X	14" D x 56" W x 58" H	88 lbs	4 Shelves (9", 13", 13", 13")	12	Y12-J	1 hr	Yes
F70-X	14" D x 70" W x 58" H	102 lbs	4 Shelves (9", 13", 13", 13")	12	Y12-C	1 hr	Yes

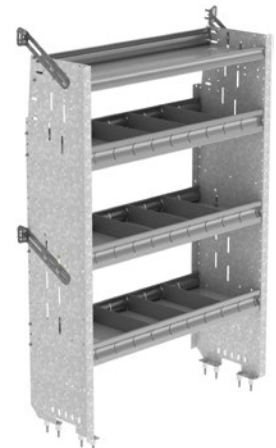

Square Back Shelving Unit with Dividers

Steel



Box Truck

Transit
High Roof

Transit
Medium
Roof

Sprinter
High Roof

Sprinter
Low Roof

NV
High Roof

ProMaster
High Roof

ProMaster



F87-X	14" D x 87" W x 58" H	125 lbs	4 Shelves (9", 13", 13", 13")	18	Y12-F	1 hr	Yes
--------------	-----------------------	---------	-------------------------------	----	-------	------	-----



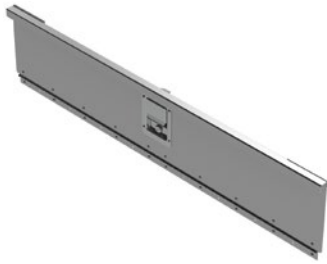

Shelving Doors

Aluminum					
		Use with shelf width			
7720	44.88" W x 8.69" H	48", 96"	7 lbs	0.5 hr	No
7722	56.88" W x 8.69" H	60"	9 lbs	0.5 hr	No
7723	32.88" W x 8.69" H	36", 72"	5 lbs	0.5 hr	No
7724	20.88" W x 8.69" H	24"	4 lbs	0.5 hr	No
7725	44.88" W x 10.38" H	48", 96"	8 lbs	0.5 hr	Yes
7727	56.88" W x 10.38" H	60"	9 lbs	0.5 hr	No
7728	32.88" W x 10.38" H	36", 72"	6 lbs	0.5 hr	Yes
7729	20.88" W x 10.38" H	24"	4 lbs	0.5 hr	No
7730	44.88" W x 12.06" H	48", 96"	8 lbs	0.5 hr	Yes
7731	38.88" W x 12.06" H	84"	8 lbs	0.5 hr	No
7732	56.88" W x 12.06" H	60"	10 lbs	0.5 hr	No
7733	32.88" W x 12.06" H	36", 72"	6 lbs	0.5 hr	No
7734	20.88" W x 12.06" H	24"	5 lbs	0.5 hr	No
7735	44.88" W x 13.75" H	48", 96"	9 lbs	0.5 hr	No
7737	56.88" W x 13.75" H	60"	11 lbs	0.5 hr	No
7738	32.88" W x 13.75" H	36", 72"	7 lbs	0.5 hr	No
7739	20.88" W x 13.75" H	24"	5 lbs	0.5 hr	No



Shelf Block

Aluminum					
		Use with shelf width			
7740	12" W x Adjustable from 11¼" to 6 5/16"	All	3 lbs	0.5 hr	No



Shelving Doors

Steel					
		Use with shelf width			
Y10-C	34.88" W x 8.69" H	70"	9 lbs	0.5 hr	Yes
Y10-D	37.88" W x 8.69" H	38"	10 lbs	0.5 hr	No
Y10-F	41.88" W x 8.69" H	42", 87"	12 lbs	0.5 hr	Yes
Y10-H	47.88" W x 8.69" H	48"	14 lbs	0.5 hr	No
Y10-M	31.88" W x 8.69" H	32"	8 lbs	0.5 hr	No
Y11-C	34.88" W x 10.38" H	70"	10 lbs	0.5 hr	Yes
Y11-D	37.88" W x 10.38" H	38"	11 lbs	0.5 hr	Yes
Y11-E	35.88" W x 10.38" H	36"	10.5 lbs	0.5 hr	No
Y11-F	41.88" W x 10.38" H	42", 87"	13 lbs	0.5 hr	Yes
Y11-M	31.88" W x 10.38" H	32"	8 lbs	0.5 hr	No
Y12-C	34.88" W x 12.06" H	70"	10 lbs	0.5 hr	No
Y12-D	37.88" W x 12.06" H	38"	12 lbs	0.5 hr	No
Y12-F	41.88" W x 12.06" H	42", 87"	14 lbs	0.5 hr	No
Y12-M	31.88" W x 12.06" H	32"	8 lbs	0.5 hr	No



Shelving Doors

Steel					
		Use with shelf width			
Y10-J	55.88" W x 8.69" H	56"	15 lbs	0.5 hr	No
Y11-J	55.88" W x 10.38" H	56"	16 lbs	0.5 hr	No
Y12-J	55.88" W x 12.06" H	56"	17 lbs	0.5 hr	No

LOCKERS & WORKBENCHES

7111

Contoured locker w/top shelf

Aluminum



Sprinter



16" D x 14" W x 62.5" H



35 lbs



1 hr



No

7119

Square back locker w/top shelf

Aluminum



Box Truck



16.5" D x 14" W x 62.5" H



39 lbs



1 hr



No

7115

Locker w/top shelf

Aluminum



Transit
Low Roof



NV
Low Roof

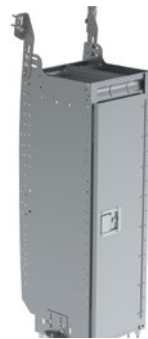

16.5" D x 14" W x 43.5" H



30 lbs



1 hr



Yes

7120

Locker w/top shelf

Aluminum



Transit
Med/High Roof



NV
High Roof



ProMaster



15.5" D x 14" W x 62.5" H



35 lbs



1 hr



Yes

7118

Contoured locker w/top shelf

Aluminum



Express



E-Series



16.5" D x 14" W x 43" H



30 lbs



1 hr



No

7207

Workbench w/hardwood top,
no shelves

Aluminum

UNIVERSAL



18" D x 48" W x 36" H



54 lbs



0.5 hr



No

SHELVING

LOCKERS & WORKBENCHES

7208

Workbench w/hardwood top,
one end panel
(Drawer cabinet not included)

Aluminum

UNIVERSAL



18" D x 48" W x 36" H



47 lbs



0.5 hr



No

7211

Workbench w/hardwood top, 2
bin shelves

Aluminum

UNIVERSAL



18" D x 48" W x 36" H



75 lbs



1 hr



No

7209

Workbench w/hardwood top,
1 shelf

Aluminum

UNIVERSAL



18" D x 48" W x 36" H



65 lbs



1 hr



Yes

7247

Workbench w/hardwood top,
one end panel
(Drawer cabinet not included)

Aluminum

UNIVERSAL



18" D x 48" W x 28" H



47 lbs



1 hr



No

7210

Workbench w/hardwood top, 1
shelf w/door

Aluminum

UNIVERSAL



18" D x 48" W x 36" H



75 lbs



1.2 hrs



No

7248

Workbench w/hardwood top, 2
bin shelves

Aluminum

UNIVERSAL



18" D X 48" W X 28" H



75 lbs



1 hr



Yes

LOCKERS & WORKBENCHES

J48-X

Square back unit with 1 open shelf & 1 workbench

Steel



Transit Med/High Roof Sprinter NV High Roof Box Truck ProMaster



14" D x 48" W x 58" H



85 lbs



1 hr



No

K48-X

Square back unit with 1 open shelf, 1 workbench & 1 pull out drawer

Steel



Transit Med/High Roof Sprinter NV High Roof Box Truck ProMaster



14" D x 48" W x 58" H



105 lbs



1 hr



No

SHELVING



7208 Workbench with hardwood top mounted with a **5060-5** 5 Drawer cabinet

WORKBENCH: A HANDY WORK STATION FOR ANY TASK



Maximize Cargo Capacity & Vehicle Performance With Contractor Grade, Organized Storage Systems

When you want the perfect upfit solution for your work vehicle, turn to Ranger Design. Crash-tested for toughness, Ranger's shelving and upfits will take whatever abuse you can dish out. Their unsurpassed craftsmanship, combined with ideal fit and finish, provide a quiet ride with no rattles.



CUSTOMER SERVICE

cs@rangerdesign.com
1-800-565-5321
rangerdesign.com



THE PERFECT FIT
FOR YOUR TOUGHEST JOBS