

Installation Instructions

Side Window Deflectors

Instruction de Montage
Deflectors sur porte

Instrucciones de Montaje
Deflectores de viento para puertas

Warning

Accessories which are not properly fitted can be danerous. Read the instructions carefully before installation, and comply with the instructions at all times. If in doubt, contact MacNeil Automotive Products Ltd.

Avertissement

Les accessoires qui ne sont pas correctement montés risquent d'être dangereux. Veuillez lire soigneusement les instructions avant d'effectuer la pose. Respectez toujours les instructions en cours de pose. En cas de doute, consultez votre concessionnaire Weathertech local.

Aviso

Aquellos accesorios que no han sido ajustados debidamente pueden resultar peligrosos. Lea las instrucciones detenidamente antes de iniciar el montaje. Durante el montaje siga las instrucciones en todo momento. en caso de duda póngase en contacto con su Concesionario de Weathertech.



Questions?
Call Customer Service @ 630-769-1500
Mon - Fri 8 AM - 5 PM
Central Daylight Time

Weathertech[®]

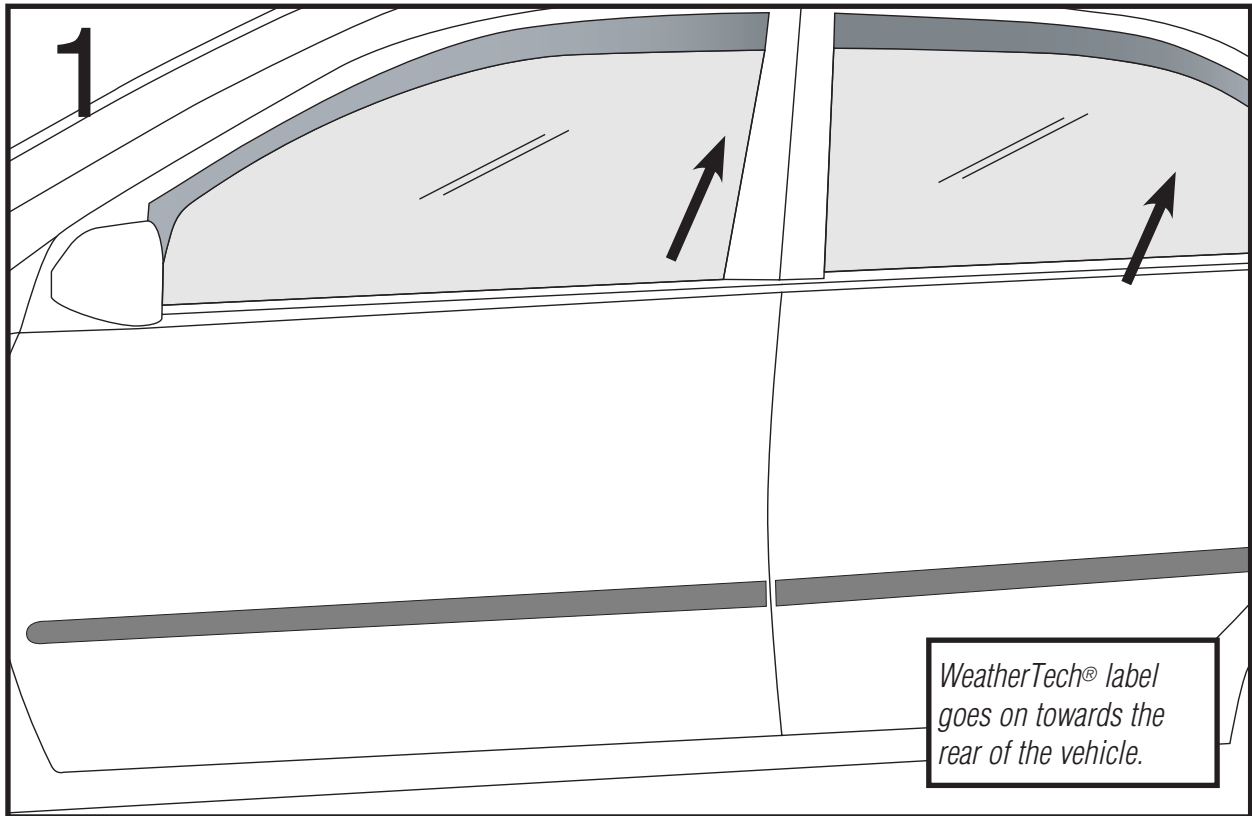

La etiqueta WeatherTech® va hacia la parte de atrás.

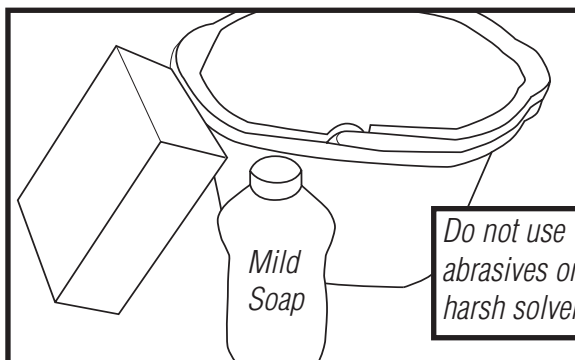
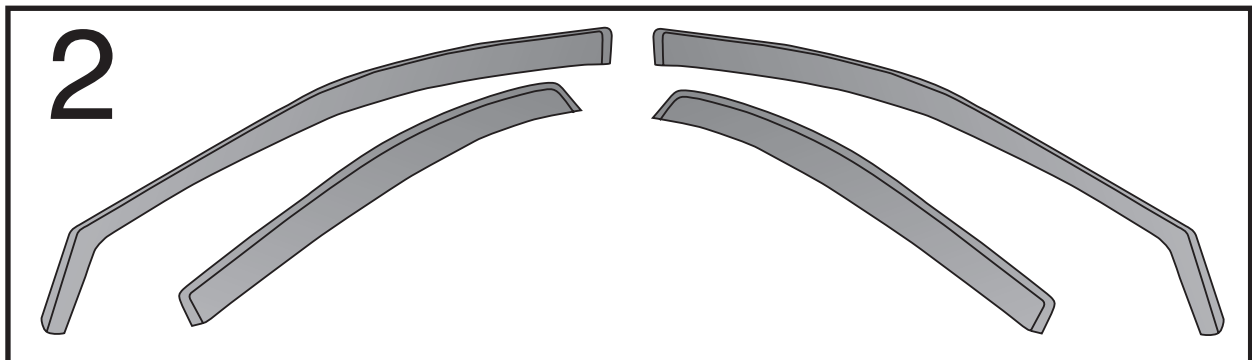

Do not use
abrasives or
harsh solvents!

No utilice solventes abrasivos o ásperos.



Limpiar la parte de arriba de la ventana.

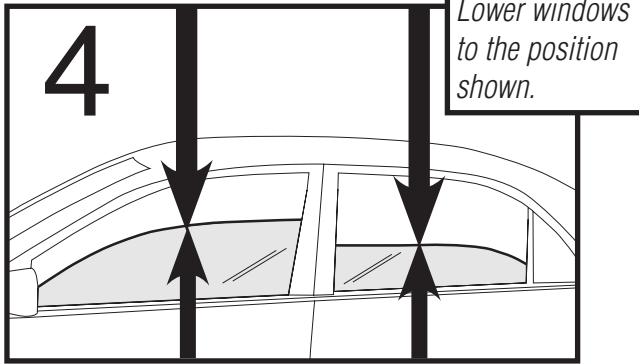

Bajar la ventana como demuestra la foto.

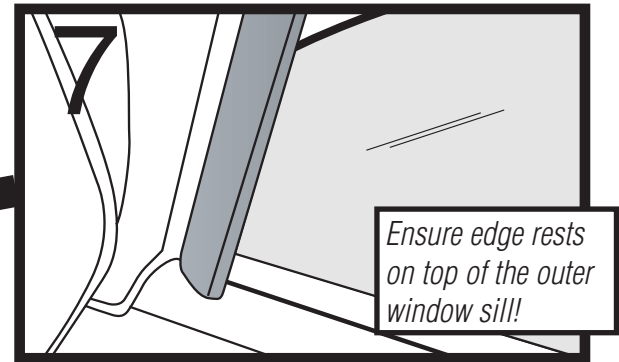
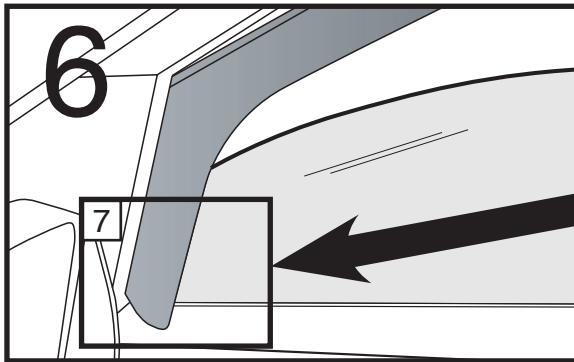
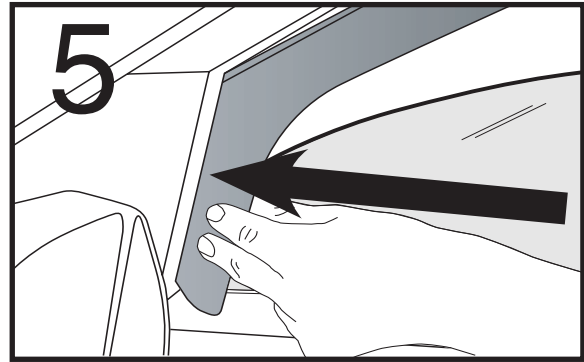

Asegúrese que la parte de abajo descansa arriba del travesaño de la ventana.

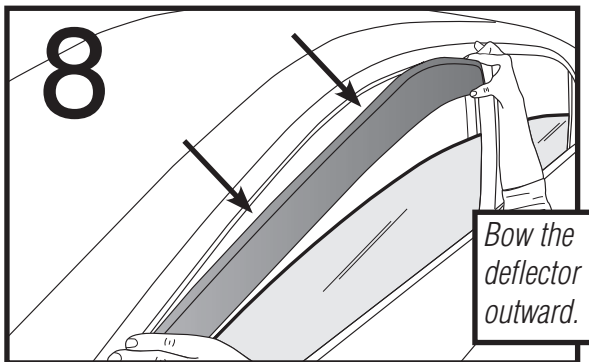

Arquee el deflector de viento hacia afuera.

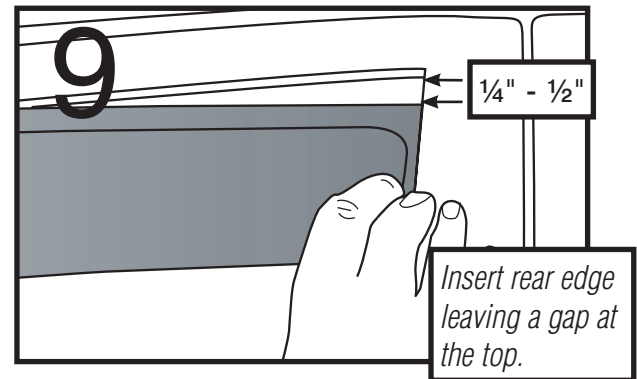

Inserte el borde posterior dejando un hueco en la parte superior.

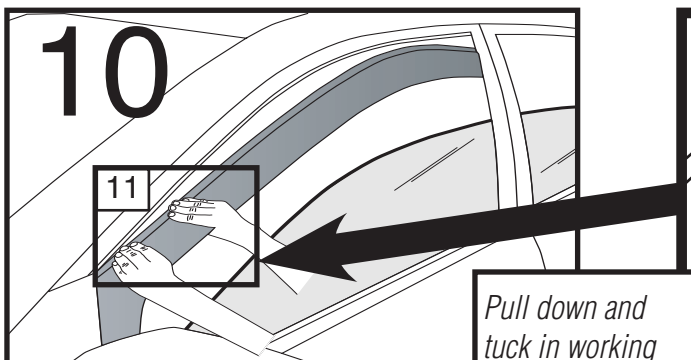

Tire hacia abajo y acomódelo empezando del frente hacia atrás.

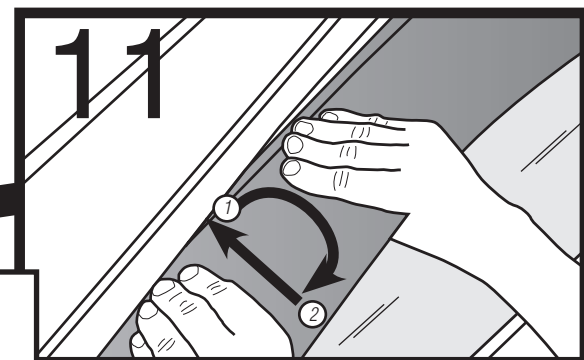

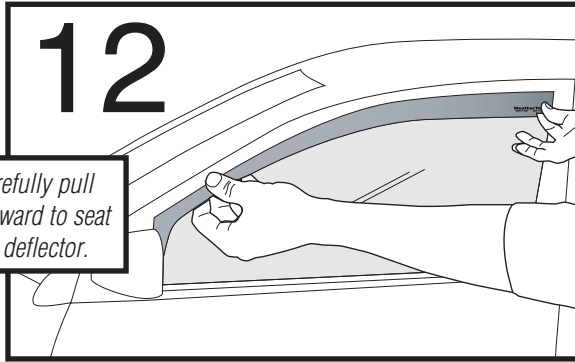

Tire suavemente hacia afuera para sentar el deflector.

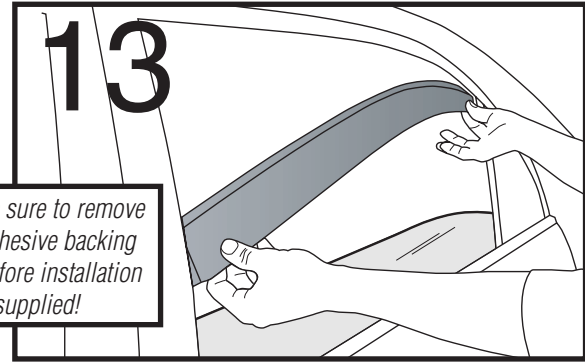

Asegúrese de quitar el forro adhesivo antes de la instalación, si es provisto.

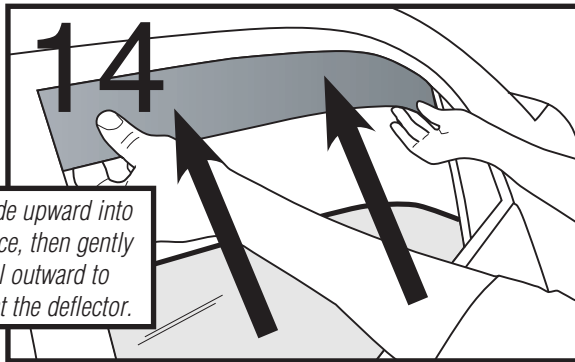

Deslice hacia arriba para acomodarlo en su lugar, después tire suavemente hacia afuera para sentar el deflector.

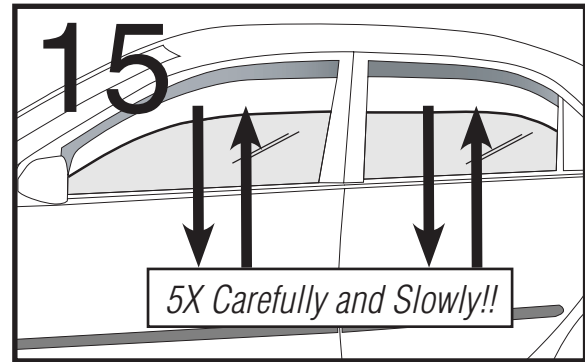

¡Cuidadosa y lentamente!

Tips for proper fit

**Ensure that the only part of the deflector inserted into the window channel is the thin, machined flange along the edge of the deflector.*

**The bottom edge of the front deflector must be resting on the door's outer weatherstrip molding. See inset of figure 5.*

**Check that the thin, machined flange of each deflector is fully and evenly inserted into the window channel. The deflector flange is designed to rest in the main window channel between the window glass and the rubber seal.*

**For windows with automatic raising feature: Roll the window all the way up without activating the automatic feature. Leave the window all the way up for at least 12 hours. The automatic raising feature should now function properly.*

**If windows are equipped with a safety feature that automatically opens the window if any resistance is met, simply sandwich the window with your hands and push upward while raising the window. This should allow the window to close fully. Leaving the window in the closed position for 12 hours will ensure proper functionality.*

**View our installation video on line at www.WeatherTech.com/install*