

M-94-21
REV. B
NOV. 1997

MAINTENANCE MANUAL



BMR-35

BMR-44

BMR-55

BMR-66

MAXON[®]
LIFT CORP.

11921 Slauson Avenue.
Santa Fe Springs, CA. 90670
(800) 227-4116

MAXON[®]

LIFT CORP.

**11921 Slauson Ave.
Santa Fe Springs, CA. 90670**

CUSTOMER SERVICE:

TELEPHONE (562) 464-0099 TOLL FREE (800) 227-4116

FAX: (888) 771-7713

**NOTE: Check with Customer Service for updated versions
of Manuals on an annual basis.**

WARRANTY POLICY & PROCEDURE

NEW LIFTGATE WARRANTY

Term of Warranty: 2 Years from Date of In-Service

Type of Warranty: Full Parts and Labor

MAXON agrees to replace any components which are found to be defective during the first 2 years of service, and will reimburse for labor based on MAXON's Liftgate Warranty Flat Rate Labor Schedule. (Call MAXON Customer Service for a copy).

All claims for warranty must be received within 30 Days of the repair date, and include the following information:

1. Liftgate Model Number
2. Liftgate Serial Number
3. Detailed Description of Problem
4. Corrective Action Taken, and Date of Repair.
5. Parts used for Repair, Including MAXON Part Number(s).
6. MAXON R.M.A. # and/or Authorization # if applicable (see below).
7. Person contacted at MAXON if applicable.

All warranty repairs must be performed by an authorized MAXON warranty station. For major repairs, MAXON Customer Service must be notified and an "Authorization Number" obtained. Major repairs would generally be considered repairs made to the structural assembly of the liftgate and/or repairs not outlined in the MAXON Liftgate Warranty Flat Rate Schedule.

Major components (i.e. hydraulic pumps, cylinders, valves, or failed structural parts) must be returned, freight pre-paid, prior to the claim being processed. To ensure timely processing of these warranty claims, an R.M.A. (Returned Merchandise Authorization) number must be obtained from MAXON Customer Service prior to the return of any defective part. Defective Parts must be returned within 60 days of the claim date for consideration to:

**MAXON Lift Corp.
16205 Distribution Way, Cerritos, CA 90703
Attn: RMA#__**

MAXON's warranty policy does not include the reimbursement for travel time, towing, vehicle rental, service calls, oil, batteries, defects due to misuse or abuse, or loss of income due to downtime. Fabrication of parts, which are available from MAXON, are also not covered.

MAXON's Flat Rate Labor Schedule takes into consideration the time required for diagnosis of a problem.

PURCHASE PART WARRANTY

Term of Warranty: 1 Year from Date of Purchase

Type of Warranty: Part Replacement

MAXON will guarantee all returned genuine replacement parts upon receipt and inspection of parts and invoice.

Table of Contents

WARNING	PAGE 4
SERVICE TIME CHART	PAGE 5
FOLDING CYLINDER REPLACEMENT	PAGE 6
LIFT CYLINDER BLEEDING.....	PAGE 7
LIFT CYLINDER REPLACEMENT	PAGE 8
RUNNER REPLACEMENT	PAGE 13
HYDRAULIC OVERRIDE LOCK	PAGE 18
RELIEF VALVE PRESSURE SETTING	PAGE 19
PUMP VALVE OPERATION	PAGE 21
OIL CHANGE INSTRUCTIONS	PAGE 23
SOLENOID CHECK	PAGE 24
SWITCH AND HARNESS REPLACEMENT	PAGE 25
TROUBLESHOOTING	PAGE 30
PLATFORM WILL NOT RAISE, MOTOR WON'T RUN	PAGE 31
PLATFORM WILL NOT PICK UP RATED CAPACITY	PAGE 32
PLATFORM RAISES HALFWAY & STOPS	PAGE 33
PLATFORM LOWERS UNEVEN	PAGE 34
PLATFORM WILL NOT CLOSE.....	PAGE 35
PLATFORM FOLDING SPEED ADJUSTMENT	PAGE 37
PLATFORM WILL NOT UNFOLD	PAGE 38
PLATFORM RAISES INSTEAD OF FOLDING	PAGE 39
TROUBLESHOOTING GRAVITY DOWN.....	PAGE 40
PLATFORM WILL NOT RAISE, MOTOR RUNS	PAGE 41
PLATFORM WILL NOT LOWER.....	PAGE 42
PLATFORM LOWERS SLOWLY	PAGE 43
TROUBLESHOOTING POWER DOWN.....	PAGE 44
PLATFORM WILL NOT RAISE, MOTOR RUNS	PAGE 45
PLATFORM WILL NOT LOWER.....	PAGE 46
PLATFORM LOWERS SLOWLY	PAGE 47

WARNING

1. Read the **Maintenance Manual** and understand it thoroughly before any maintenance of this unit is done.
2. Read the **YELLOW** urgent warning decal on the side of the vehicle close to the unit before operating.
3. If decals are dirty, clean them. If decals are defaced or missing, replace them. **Free replacements** are available from the manufacturer. See information at the end of the Warnings
4. Be aware that the safety and location of other people or objects should be considered before operation of this unit. Stand to one side of platform while operating this unit.
5. Do not stand under, or have any foreign object under the Platform when lowering. **Be sure that the lowering of the Platform and/or Flipover will miss your feet!**
6. Keep fingers, hands, arms, legs, and feet clear of moving parts when operating this unit.
7. If during your maintenance procedure, it becomes necessary to ride the platform, keep your feet and any foreign objects clear of the rear edge of the platform. Otherwise your feet or the foreign objects could become trapped between the edge of the platform and the vehicle bed.
8. Inspect all Roll Pins monthly, to insure that they are not broken. Replace if broken.
9. Inspect all hydraulic hoses and fittings annually. Check for cracks and deterioration, and replace if necessary.
10. **Disconnect battery** when replacing parts or servicing.
11. Do not allow children to ride, play with, or operate this unit.
12. In the event of an emergency while operating the unit, release the toggle switch and the unit will stop immediately.
13. A properly installed Lift should operate smoothly and the only noise during the operation of this unit should be from the Pump Unit during the raising of the Platform. Any scraping, grating or audible indications of rough operation will need investigating. The cause will need resolving before any further deterioration of performance occurs.
14. Use only **Maxon Authorized Parts** for replacement. Replacement parts should be ordered from:

MAXON LIFT CORP. Parts Department
11921 Slauson Ave., Santa Fe Springs, Ca. 90670
Phone: (800) 227-4116

SERVICE TIME CHART

SERVICE TO BE PERFORMED		TIME REQ'D. (HOURS)
CHANGE LIFT CYLINDER	RIGHT SIDE	2.00
	LEFT SIDE	1.50
CHANGE PLATFORM CLOSER CYLINDER		1.00
CHANGE MOTOR		0.50
CHANGE MOTOR SOLENOID		0.50
CHANGE POWER PACK, COMPLETE		1.00
CHANGE/CLEAN CARTRIDGE VALVE		0.50
CHANGE PUMP RESERVOIR		1.50
CHANGE RIDE EQUALIZER		0.50
CHANGE EXTERNAL RELIEF VALVE		0.50
CHANGE O/S SWITCH ASSEMBLY		0.50
CHANGE CIRCUIT BREAKER		0.50
CHANGE ROLLERS OR ROLLER BEARINGS (PER RUNNER)		1.50
CHANGE PLATFORM MAIN SECTION		2.00
CHANGE PLATFORM FOLDING SECTION		1.00
REPLACE PLATFORM SUPPORT CHAIN ASSEMBLY (EACH)		0.50
REPLACE FOLDING SECTION HINGE BEARINGS		1.50
REPLACE FOLDING SECTION HINGE PINS		0.75
REPLACE MAIN HINGE PINS (PER SIDE)		0.50
REPLACE MAIN PLATFORM HINGE BRNGS.	PER SIDE	1.00
	BOTH SIDES	1.50
CHANGE EXTERNAL HYDRAULIC HOSES (EACH)		0.25
CHANGE CLOSER CYLINDER HOSE IN RUNNER		2.00
BLEED LIFT CYLINDER (PER SIDE)		1.50
RESET PUMP AND RELIEF VALVE PRESSURE		0.50
CHANGE RUNNER TOGGLE SWITCH HARNESS		2.50
CHANGE CYLINDER LOCK VALVE HARNESS		1.50

MAXON[®] 11921 Slauson Ave. Santa Fe Springs, CA. 90670 (800) 227-4116 FAX (888) 771-7713

FOLDING CYLINDER REPLACEMENT

1. Lower the Platform to the ground.
2. Disconnect and plug the Hydraulic Hose from the lower part of the Cylinder (for cleanliness).
3. Remove the Lower Roll Pin from the Inside Coupling and then remove the Lower Cylinder Pin.
4. Remove the Upper Roll Pin from the Runner Weldment and then remove the Upper Cylinder Pin.
5. Replace the Cylinder and reverse these steps for re-assembly.

NOTE:

Be sure the new Cylinder has a 1-3/4" Outside Diameter Rod End. This will ensure that the correct cylinder is being used.

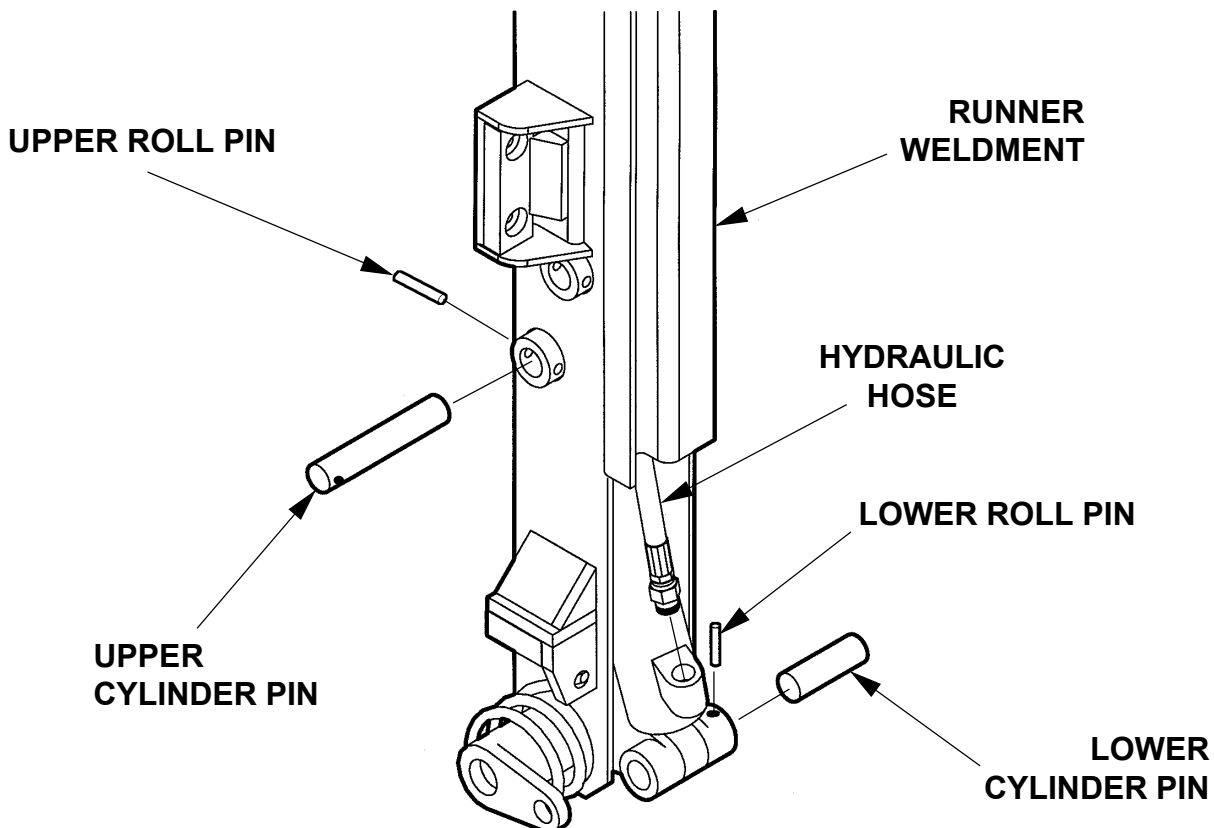

LIFT CYLINDER BLEEDING

NOTE: This operation must be performed in a location where the maximum distance of 60” between the ground and the vehicle bed may be obtained.

1. Lower the opened platform to the ground.

2. Loosen, but do not disconnect the **Cylinder Fitting** from the **Pressure Compensated Flow Control Valve**, located at the top of both Lift Cylinders.

**Pressure Compensated
Flow Control Valve**

Cylinder Fitting

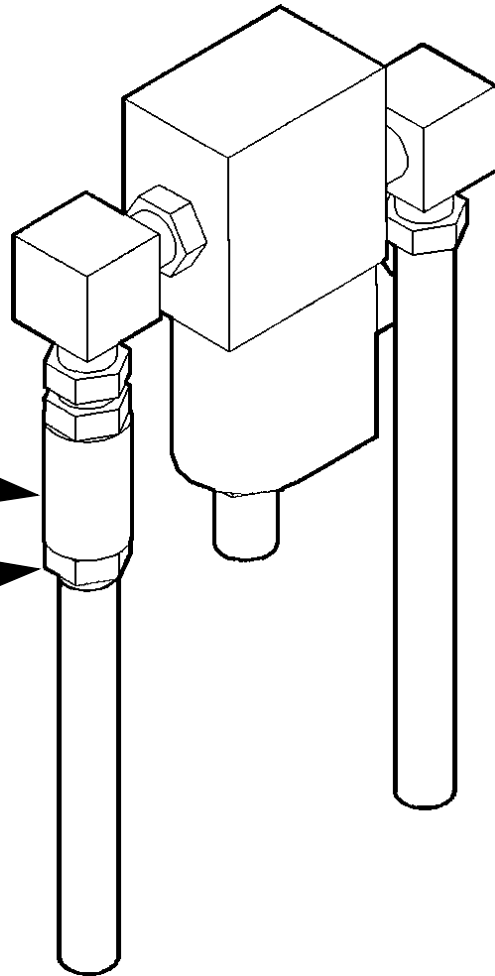

3. Activate the “RAISE” switch for approximately one second and then release the switch. Wait ten seconds and repeat. Repeat this procedure until there is no air leaking from the loosened fittings, then tighten those fittings.

4. Raise and lower the platform to see if the unit operates smoothly. If so, raise, fold, and store the Platform.

LIFT CYLINDER REPLACEMENT

1. Raise the open Platform about 20" above the ground. Place a jack under the Platform and raise an additional 3" or 4". Measure the distance between the Cylinder Pins and record this distance for later use.

2. Remove the Column Cover from the top of the Column.

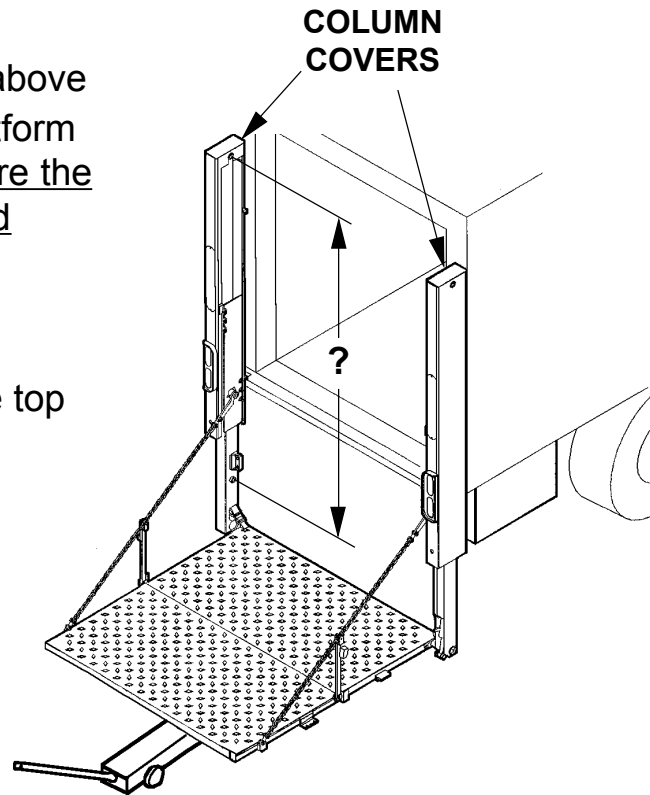

NOTE:

If your unit was one of the first in production, it came equipped with an Extension Tube Assembly (shown below Left). If so, skip Step 3 and go to Step 9. If your unit has **no** Extension Tube Assembly (shown below Right), then proceed with Step 3.

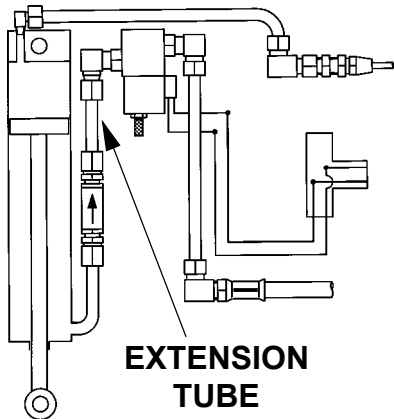

EXTENSION
TUBE

3. Remove the Coil Nut from the Lock Valve & Coil. Slide off the Coil and unscrew the Valve Cartridge (screwed into the Valve Block). Remove the bolts (if any), that secure the Valve Block to the Column.

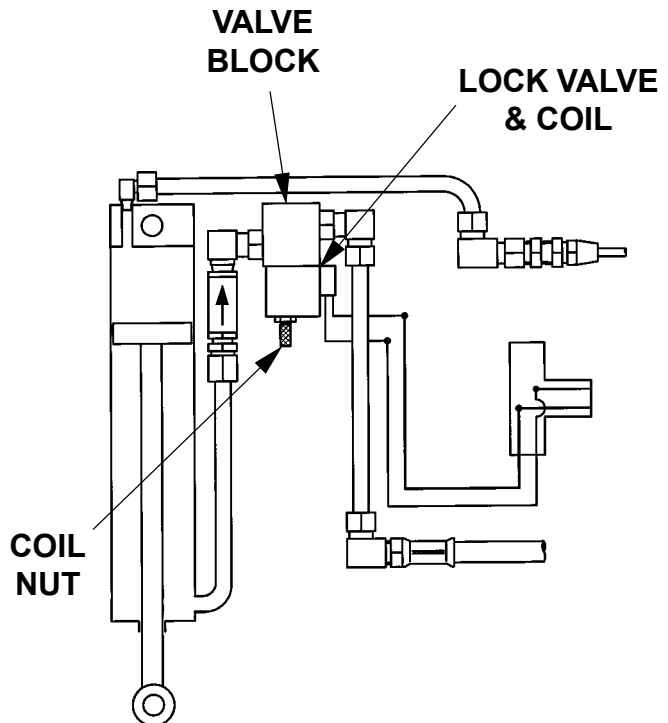

LIFT CYLINDER REPLACEMENT

4. Remove the Nut from the Elbow on the top of the Cylinder. Loosen, but do not remove the Nut on the Elbow of the Valve Block.

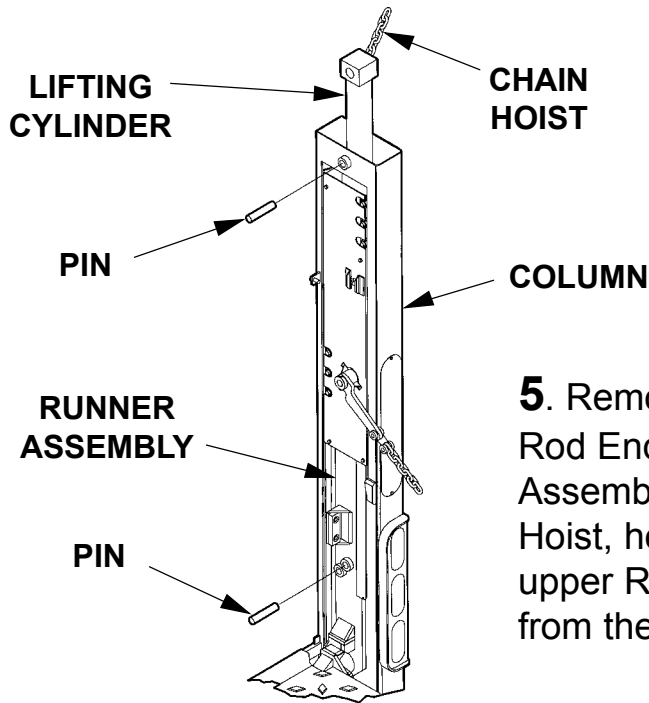
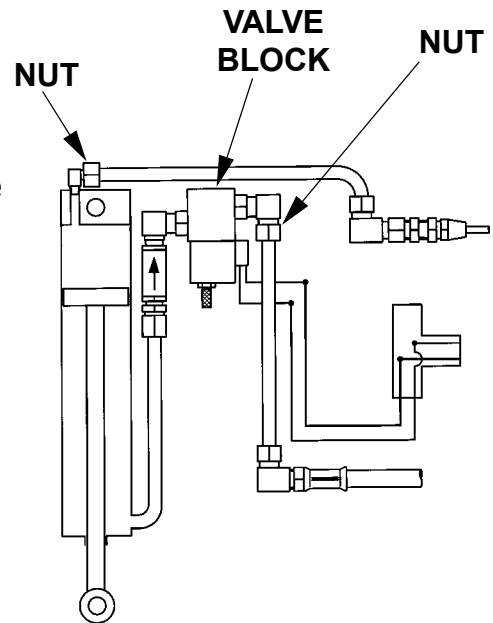

5. Remove the Roll Pin & Pin that fastens the Rod End of the Lift Cylinder to the Runner Assembly. Using a device such as a Chain Hoist, hold the Lift Cylinder while removing the upper Roll Pin & Pin. Remove the Lift Cylinder from the top of the Column.

6. Remove the Plug from the compression fitting on the New Lift Cylinder. Fasten a Drain Hose with a 1/4" NPT Female end to the compression fitting. Place the other end of the Hose in a 1 gallon container for bleeding. Pull the Rod End of the Cylinder until the distance between the Pins are the same as measured in Step 1. Re-attach the Hyd. Lock Valve and Pressure Comp. Valve with all their fittings.

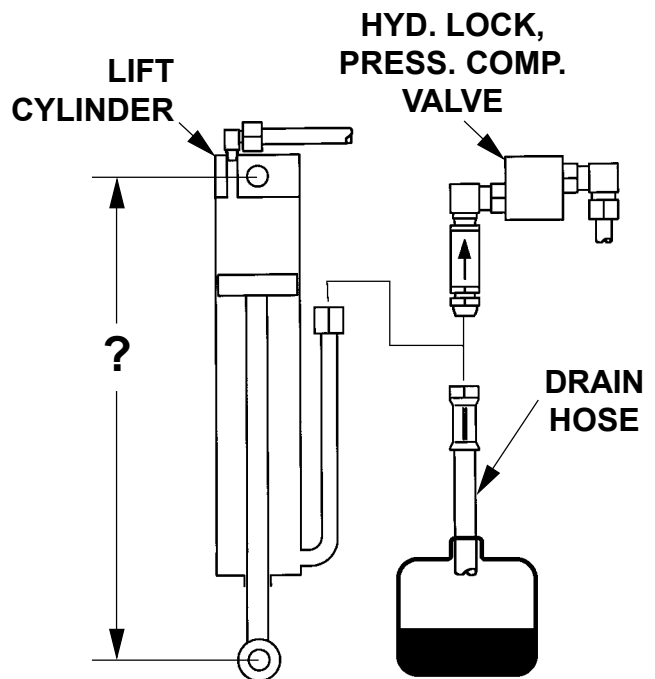

NOTE: Be sure the arrow on the Pressure Comp. Valve is pointing up.

LIFT CYLINDER REPLACEMENT

7. Lower the New Lift Cylinder through the top of the Column. Fasten at the top with the Pin & Roll Pin. Then fasten at the Rod End of the Cylinder with the Pin & Roll Pin.

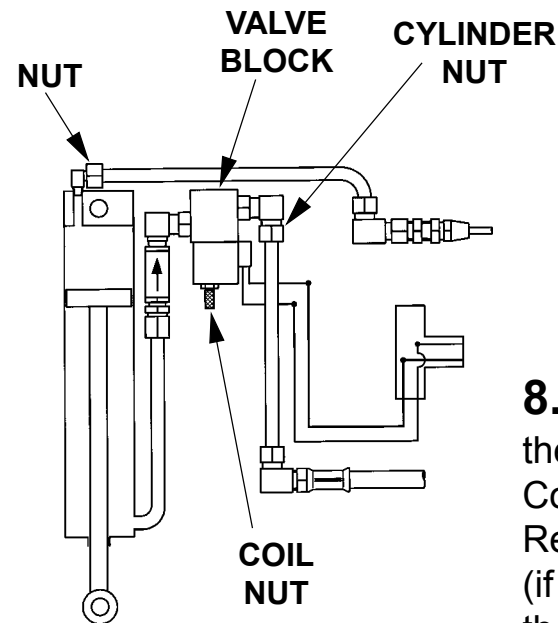
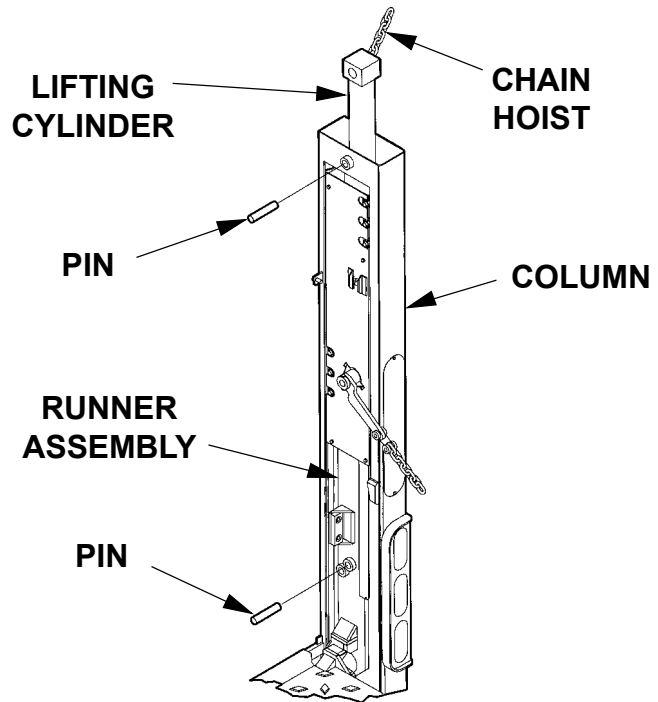

8. Re-connect the Nut to the Elbow on top of the Cylinder. Re-install the Valve Cartridge, Coil, and Coil Nut to the Hyd. Lock Valve. Re-attach the Hyd. Lock Valve to the Column (if needed). Re-connect the Cylinder Nut to the Hyd. Lock Valve.

FOR UNITS SHIPPED IN EARLY 1994

9. Remove the Coil Nut from the Lock Valve & Coil. Slide off the Coil and unscrew the Valve Cartridge (screwed into the Valve Block). Remove the bolts (if any), that secure the Valve Block to the Column. Loosen, but do not remove the Nut on the Elbow of the Valve Block.

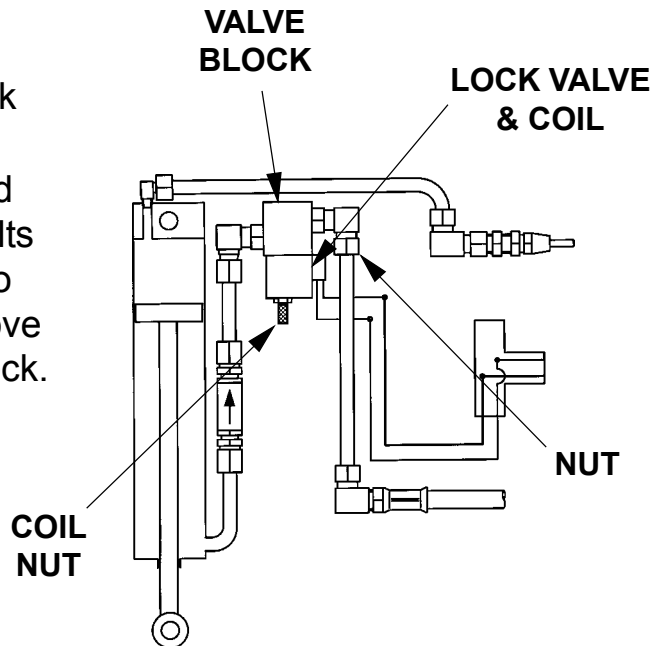

LIFT CYLINDER REPLACEMENT

10. Remove the Roll Pin & Pin that fastens the Rod End of the Lift Cylinder to the Runner Assembly. Using a device such as a Chain Hoist, hold the Lift Cylinder while removing the upper Roll Pin & Pin. Remove the Lift Cylinder from the top of the Column.

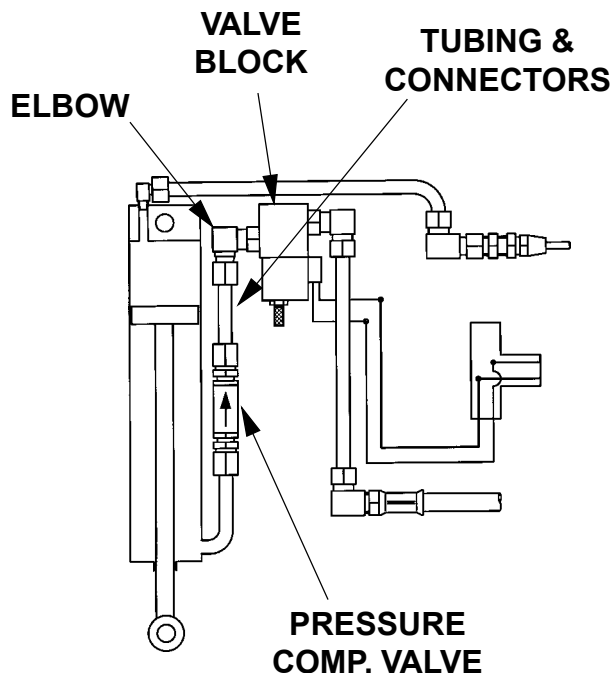
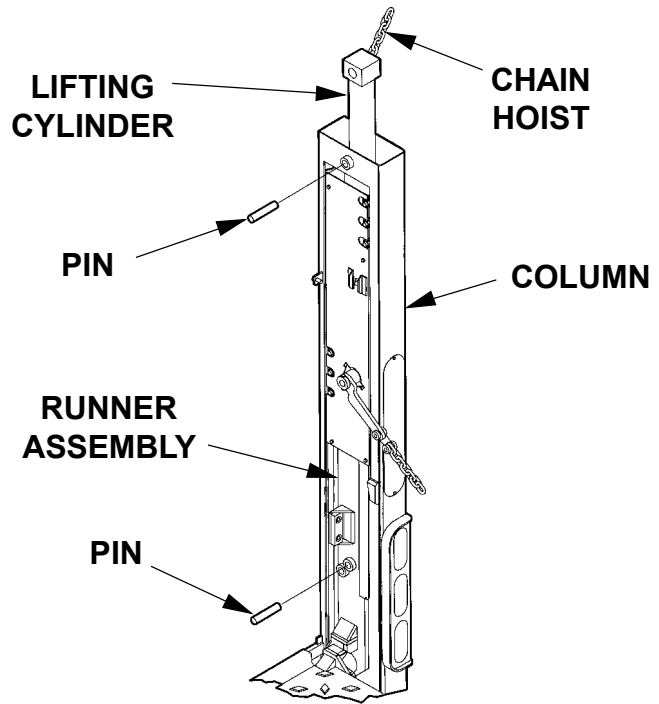

11. Remove the Tubing & Connectors and discard them. Remove the Elbow from the Valve Block and replace it with a new Elbow, #6M x 1/4 NPT (P/N 260164). Fasten the Pressure Comp. Valve to the new Elbow. **NOTE:** Be sure the arrow on the Pressure Comp. Valve is pointing up.

LIFT CYLINDER REPLACEMENT

MAXON

11921 Slauson Ave. Santa Fe Springs, CA. 90670 (800) 227-4116 FAX (888) 771-7713

12. Remove the Plug from the compression fitting on the New Lift Cylinder. Fasten a Drain Hose with a 1/4" NPT Female end to the compression fitting. Place the other end of the Hose in a 1 gallon container for bleeding. Pull the Rod End of the Cylinder until the distance between the Pins are the same as measured in Step 1. Re-attach the Hyd. Lock Valve and Pressure Comp. Valve with all their fittings.

NOTE: Be sure the arrow on the Pressure Comp. Valve is pointing up.

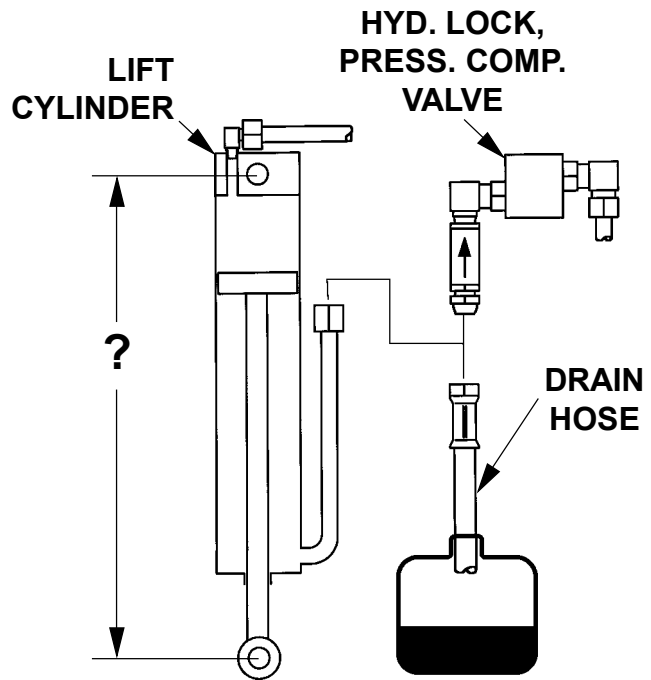

13. Lower the New Lift Cylinder through the top of the Column. Fasten at the top with the Pin & Roll Pin. Then fasten at the Rod End of the Cylinder with the Pin & Roll Pin.

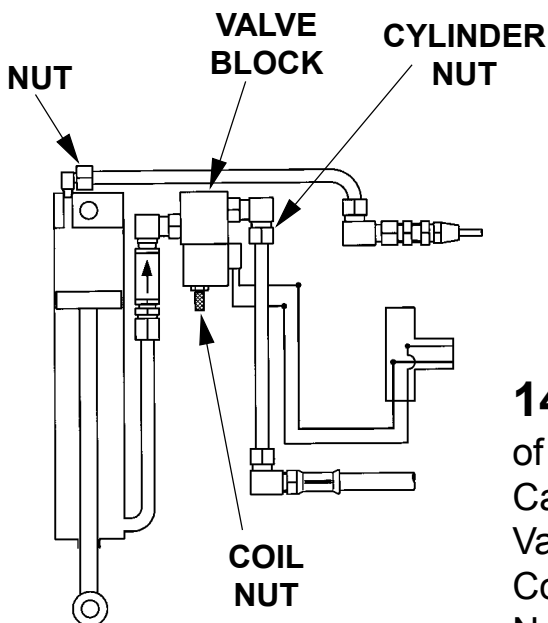
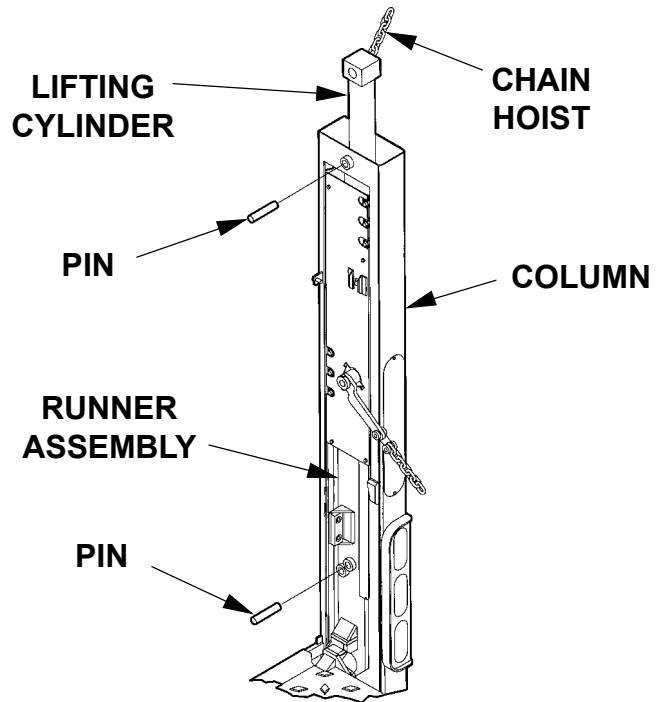

14. Re-connect the Nut to the Elbow on top of the Cylinder. Re-install the Valve Cartridge, Coil, and Coil Nut to the Hyd. Lock Valve. Re-attach the Hyd. Lock Valve to the Column (if needed). Re-connect the Cylinder Nut to the Hyd. Lock Valve.

RUNNER REPLACEMENT

REMOVE OLD RUNNERS

1. Lower the opened Platform and let it rest on a stand approximately 25" off of the ground. Be sure to allow access to a forklift to position the Runner.

2. Remove the Bolts, Pins, Chain Arms, and Covers from the Runners and Platform.

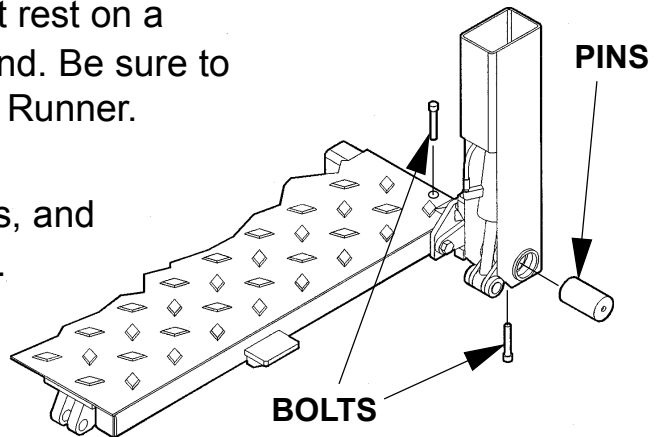
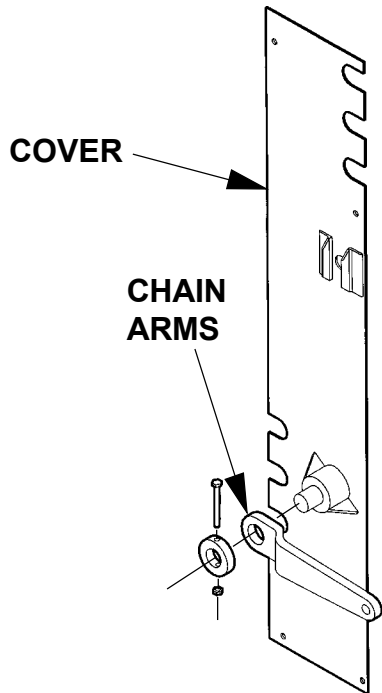

3. Use a Forklift to slide the Platform forward, towards the cab of the vehicle approximately 6", or enough to clear the Platform away from the Runner Brackets. Raise the Runners about 6" and slide the Platform away from the cab far enough to create a workplace to remove the Runners.

4. Lower the Runners to the ground. Remove the Upper and Lower Pad Assemblies, and the two Tandem Assemblies.

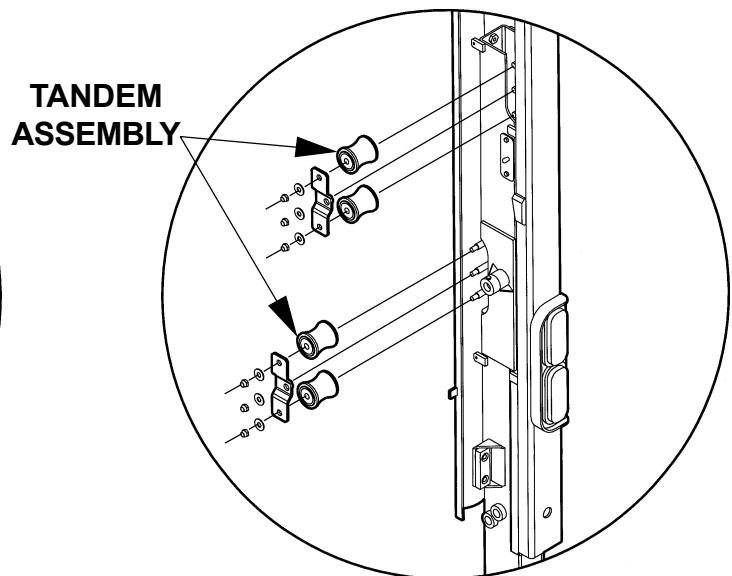
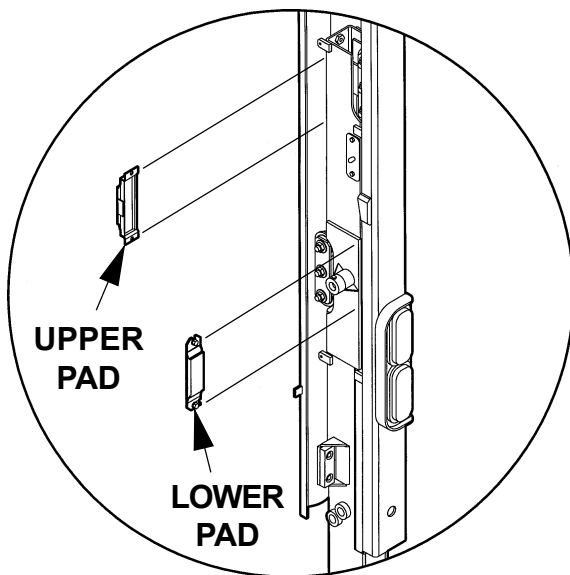

RUNNER REPLACEMENT

5. Remove the Pins from the old Runner, (two Pins on the R.H. Runner, and one Pin on the L.H. Runner). Do not remove the Upper Cylinder Pin at this time. Activate the Control Switch to the "UP" position to fully retract the Lift Cylinders.

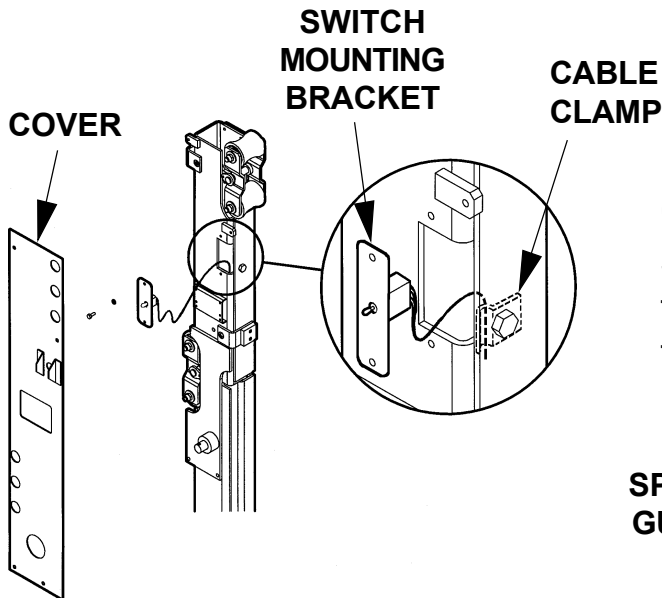
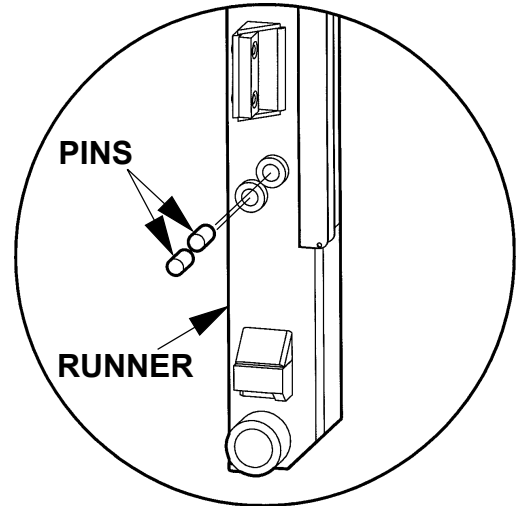

6. R.H. COLUMN ONLY remove the Switch Mounting Bracket. Remove the terminals from the Switch and release the electric cable from the clamp inside the hole.

7. Remove the Spring Guard and Harness in the channel of the Runner Assembly. Remove the Hose from the Closing Cylinder. Remove the 1" Dia. Pin from the Rod End of the Closing Cylinder and place the Closing Cylinder aside.

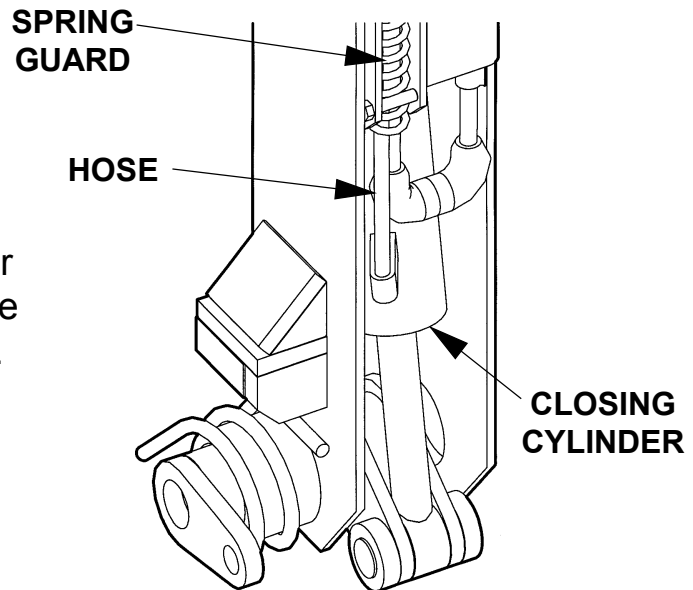

NOTE:

If the Bed Height of the Vehicle is 54" or more from the Ground, go to Step 9.

MAXON

11921 Slauson Ave. Santa Fe Springs, CA. 90670 (800) 227-4116 FAX (888) 771-7713

RUNNER REPLACEMENT

8. Remove the Column Cover from the top of the Column. Remove the Coil Nut from the Lock Valve & Coil. Slide off the Coil and unscrew the Valve Cartridge (screwed into the Valve Block). Remove the bolts (if any), that secure the Valve Block to the Column.

Remove the Nut from the Elbow on the top of the Cylinder. Loosen, but do not remove the Nut on the Elbow of the Valve Block.

Using a device such as a Chain Hoist, hold the Lift Cylinder while removing the upper Roll Pin & Pin. Raise the Cylinder until the Rod End of the Cylinder clears the top of the Runner.

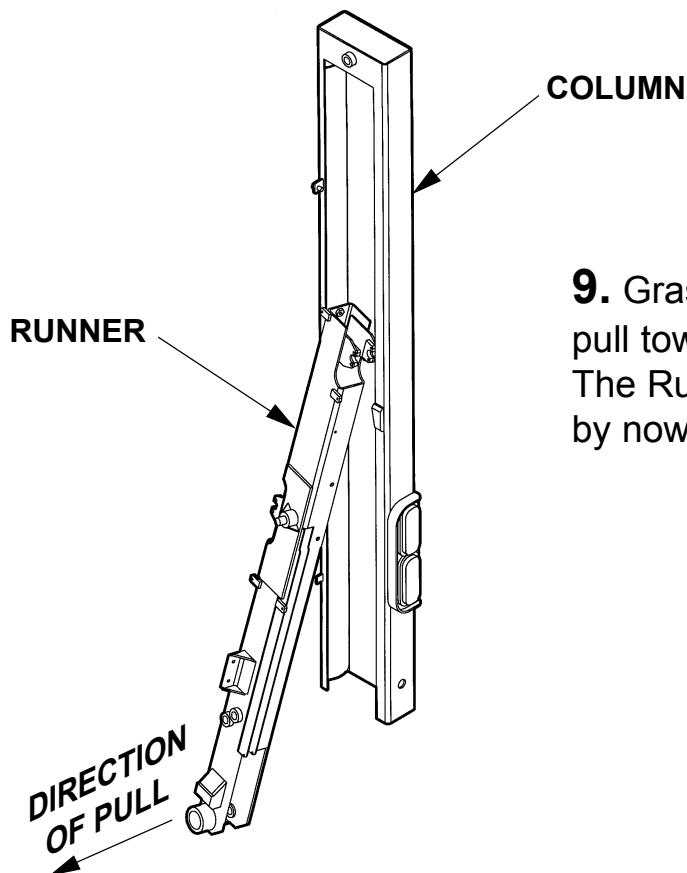
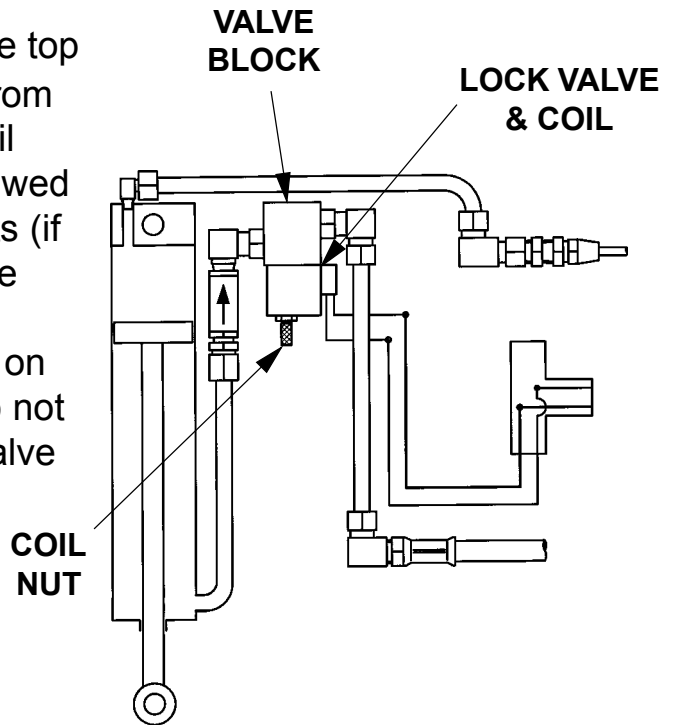

9. Grasp the lower end of the Runner and pull towards the centerline of the vehicle. The Runner should be free of the Column by now. Repeat for the other side.

RUNNER REPLACEMENT

INSTALL NEW RUNNERS

10. Remove the remaining parts of the two Tandem Roller Assemblies from the Old Runners and place them on the New Runners. The remaining parts for each Tandem Assembly consist of: (1) Roller Bracket Weldment, (3) Roller Axles, and (2) Mounting Brackets.

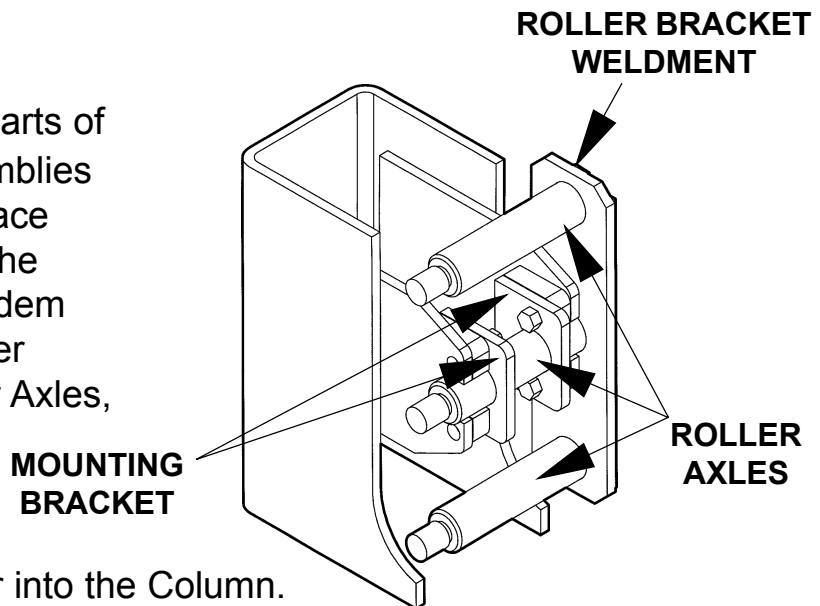

11. Position the New Runner into the Column. Replace the Rollers on the Roller Axles and fasten them with the Washers and Nuts. Be certain the Roller Axels are positioned against the Roller Bracket Weldment so they don't rotate on the Bracket.

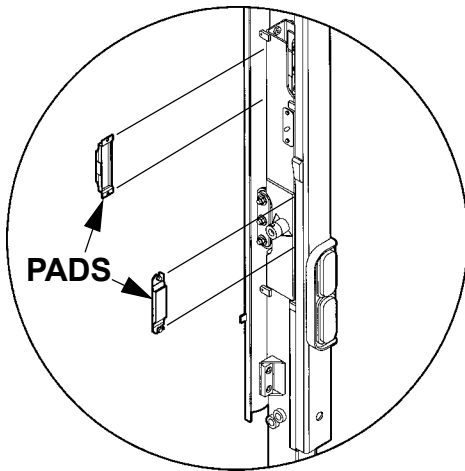

12. Replace the Upper and Lower Pads on the front and back of the Runner.

13. FOR R.H. RUNNER ONLY, tie a 10 ft. piece of wire to the electrical cable that was removed from the Switch. Insert the opposite end of the wire through the bottom of the Runner and bring it out through the Switch opening in the Runner.

14. If the Lifting Cylinders were detached from the Column, replace them and fasten them back to the top of the Column with the Pin and Roll Pin. Tighten or replace any hydraulic fittings you may have removed from the top of the Cylinder. Replace the Cover on the Column.

MAXON

11921 Slauson Ave. Santa Fe Springs, CA. 90670 (800) 227-4116 FAX (888) 771-7713

RUNNER REPLACEMENT

15. Activate the “DOWN” switch on the Control Panel to extend the Cylinders. Attach the Lifting Cylinder to the Runner with the Pin and Roll Pin. On the R.H. Runner only, attach the fixed end of the Closing Cylinder to the Runner with the Pin and Roll Pin. Re-attach the Spring Guard and Harness to the Runner.

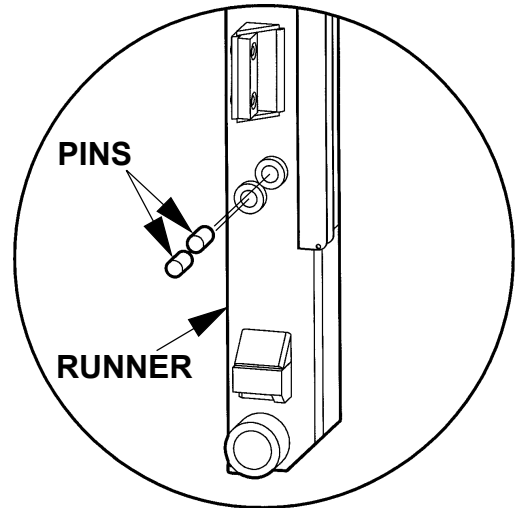

16. Pull the electrical cables through the Switch Mounting Bracket hole and tighten the Cable Clamp inside the Runner. Replace the wires to the switch per the diagram below. Replace the Switch Mounting Bracket to the R.H. Runner and re-connect the Hose to the Closing Cylinder.

17. Re-assemble the Platform to the Runners in reverse order.

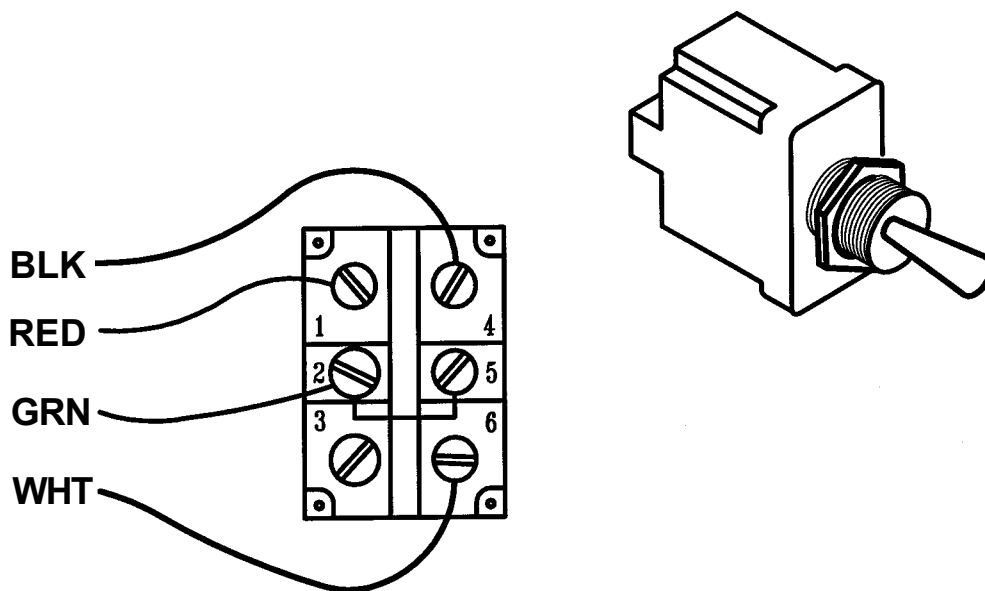

HYDRAULIC OVERRIDE LOCK

In the event that the BMR Column Lift will not lower, you will need to disengage both of the Hydraulic Override Locks. There is one located at the top of each Column.

To disengage, you must pull down on the Coil Nut and twist until it locks into place. To re-engage you must twist the Coil Nut and release. It will spring back into the original "Locked" position. Be sure to re-engage the Override Locks before moving the vehicle.

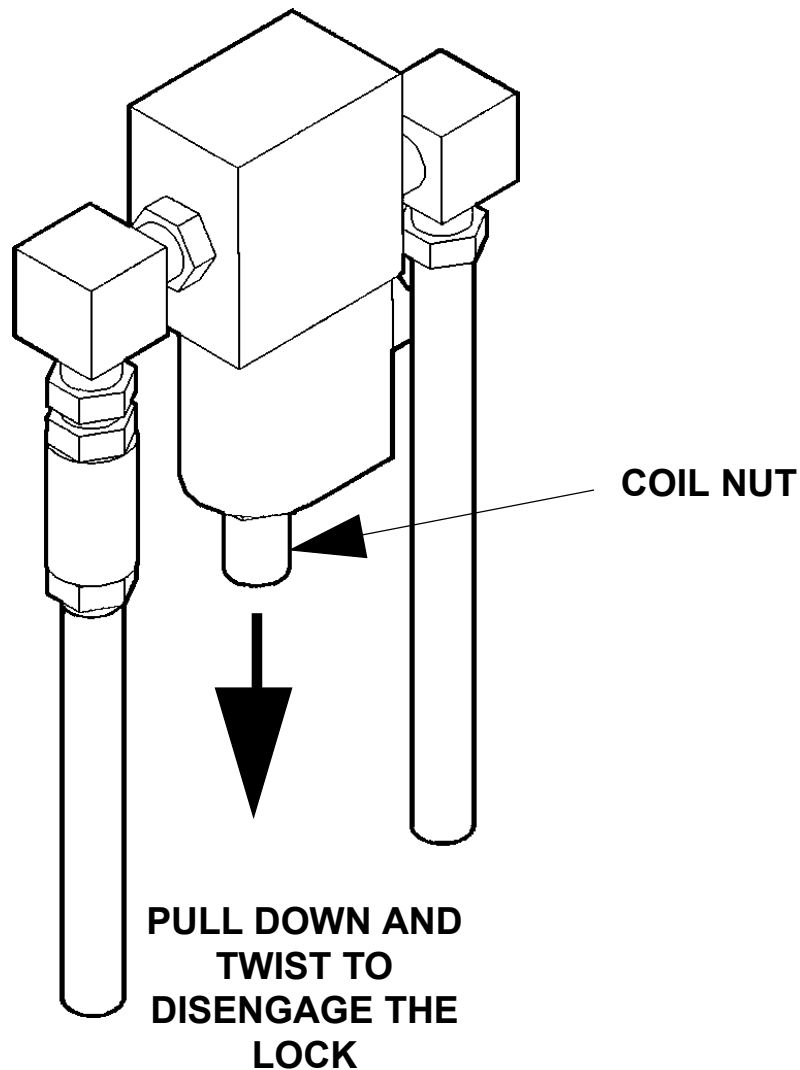

MAXON

11921 Slauson Ave. Santa Fe Springs, CA. 90670 (800) 227-4116 FAX (888) 771-7713

RELIEF VALVE PRESSURE SETTING

OLD STYLE RELIEF VALVE

The Relief Valve pressure is set at the factory. If adjustment is needed, use the following instructions to set the pressure per the table below.

WARNING!

Setting the pressure higher than recommended could result in damage to your unit.

1. For better access, remove the two screws which fasten the Relief Valve Assembly to the back of the Pump Box. Remove the Hose from the Tee Fitting.

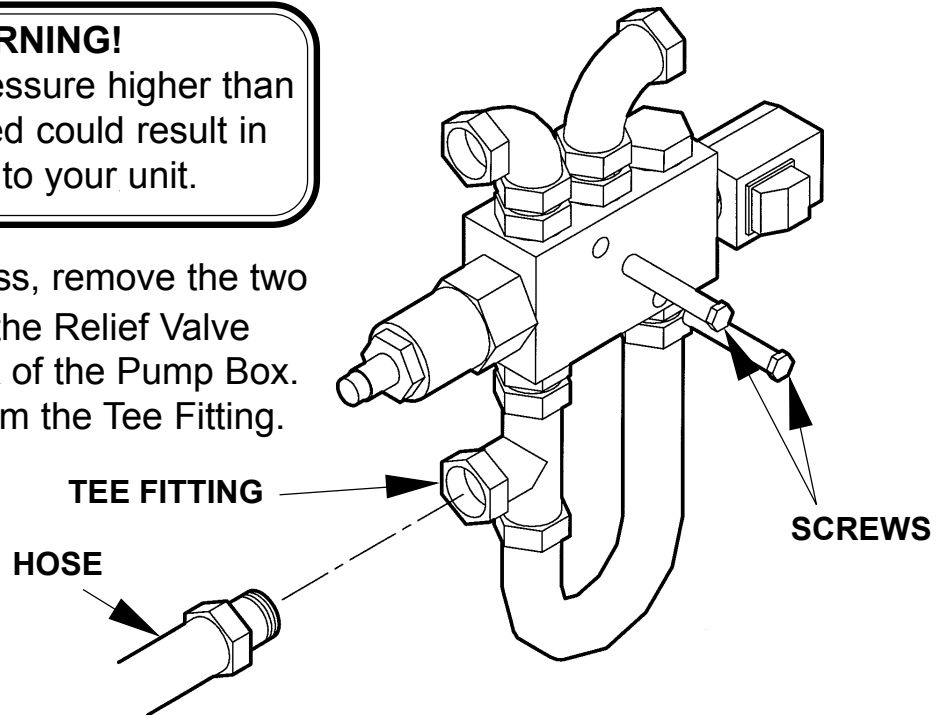

2. Attach a 0-3000 PSI gauge to the Tee Fitting. Actuate the Control Switch to the "Raise" position. Turn the Relief Valve Adjustment Screw to the proper setting. (Hint: Adjust the setting to approximately 300 psi below the desired pressure, and slowly raise the pressure until you reach the recommended pressure shown in the table below.)

MODEL	P.S.I.
BMR-35	1750
BMR-44	1800
BMR-55	2100
BMR-66	2400

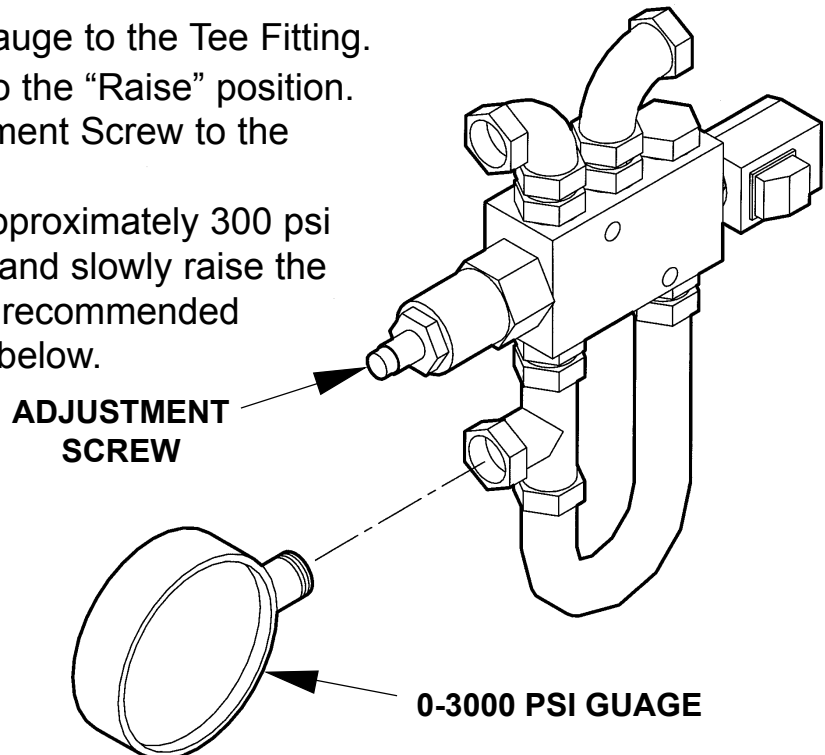

RELIEF VALVE PRESSURE SETTING

NEW STYLE RELIEF VALVE

The Relief Valve pressure is set at the factory. If adjustment is needed, use the following instructions to set the pressure per the table below.

1. Attach a 0-3000 PSI gauge to the Pressure Port. Actuate the Control Switch to the "Raise" position. Turn the Relief Valve Adjustment Screw to the proper setting. (Hint: Adjust the setting to approximately 300 psi below the desired pressure, and slowly raise the pressure until you reach the recommended pressure shown in the table below.

RELIEF VALVE
ADJUSTMENT SCREW

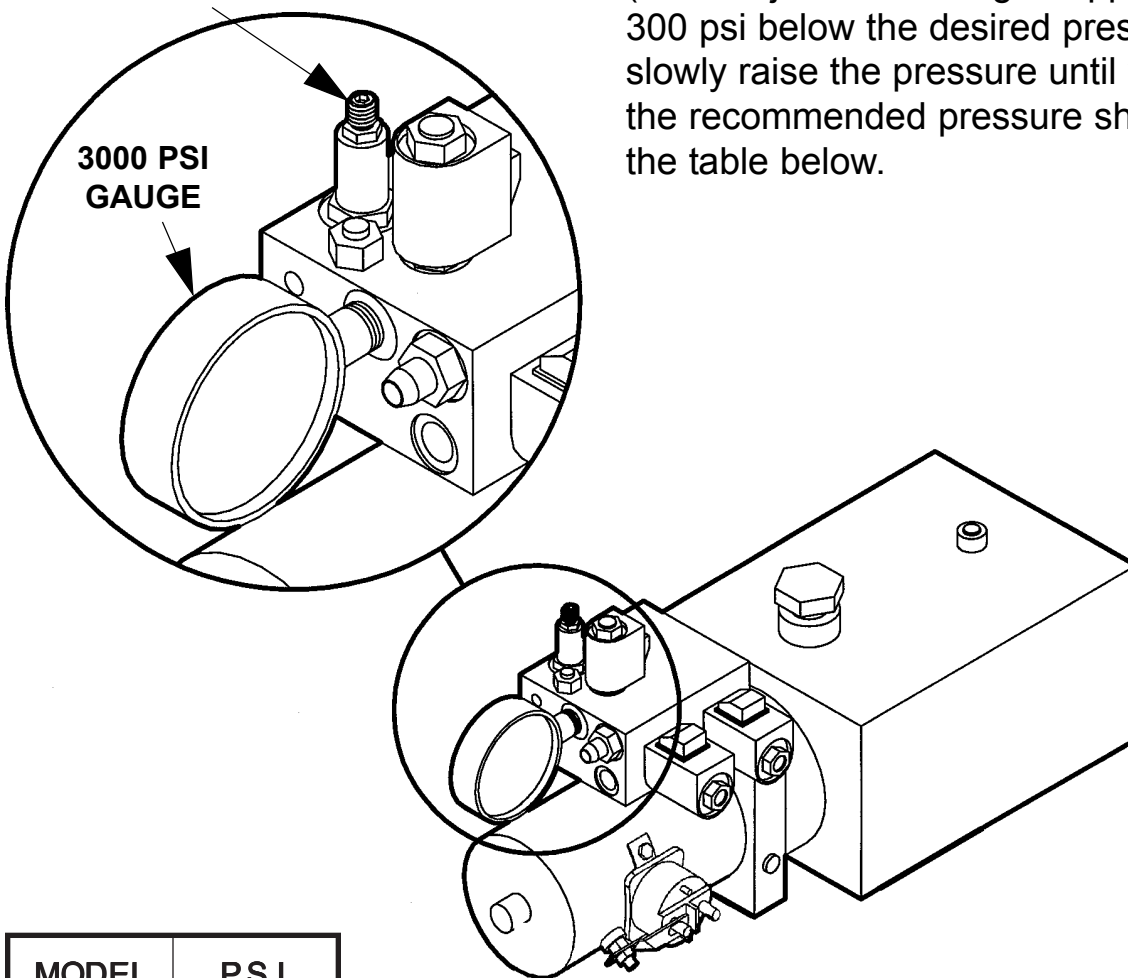

MODEL	P.S.I.
BMR-35	1750
BMR-44	1800
BMR-55	2100
BMR-66	2400

WARNING!
Setting the pressure higher than recommended could result in damage to your unit.

MAXON[®]

11921 Slauson Ave. Santa Fe Springs, CA. 90670 (800) 227-4116 FAX (888) 771-7713

PUMP VALVE OPERATION

OLD STYLE PUMP

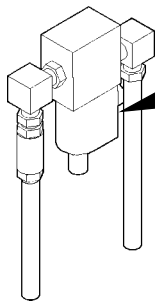

"D" Valves
Located inside the
top of each Column

VALVES A,B,C, or D, Energized

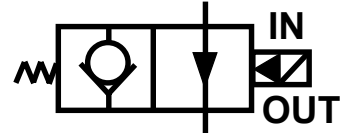

FREE FLOW IN

"C" Valve
Located in
Pump Box

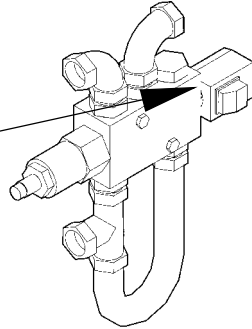

VALVES A,B,C, or D, Not Energized

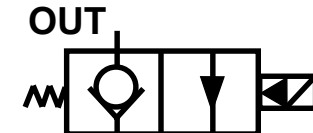

FREE FLOW OUT

"B" Valve
Lifting Port

"A" Valve
Folding Port

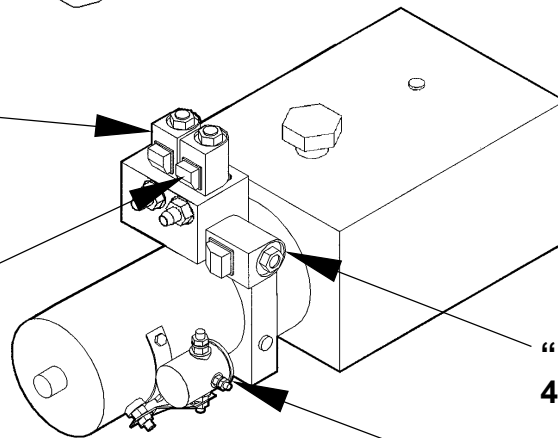

"E" Valve
4-Way Valve

"M" Valve
Motor Solenoid

SOLENOID OPERATION - OLD GRAVITY DOWN UNITS		
FUNCTION COMMAND	SOLENOID ENERGIZED	RESULTING ACTION
RAISE	M	Motor runs; Oil flows from "B" Port thru Relief Valve, thru Ride Equalizer, thru "D" Valves to Lift Cylinders
LOWER	B,C,D,& E	"E" Valve shifts; "B,C,& D" Valves open, allowing oil to return from Lift Cylinders to the Reservoir
FOLD PLATFORM	M & E	Motor runs; "E" Valve shifts, Oil flows from Port "A" to the Fold Cylinder.
OPEN PLATFORM	A	"A" Valve opens, allowing oil to return from the Folding Cylinder to the Reservoir.

PUMP VALVE OPERATION

NEW STYLE PUMP

VALVES A,B,C, or D, Energized

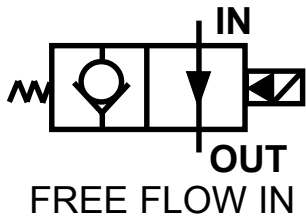

VALVES A,B,C, or D, Not Energized

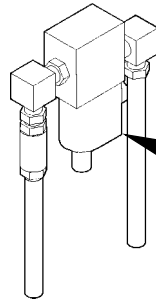
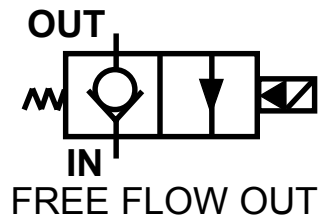

"D" Valves
Located inside the
top of each Column

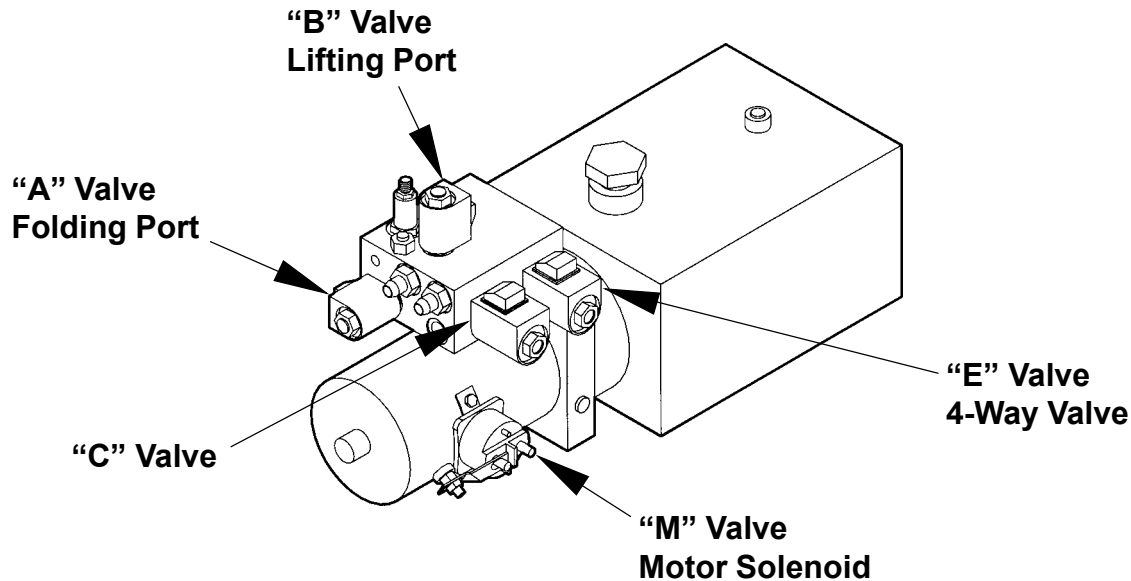

SOLENOID OPERATION - NEW GRAVITY DOWN UNITS		
FUNCTION COMMAND	SOLENOID ENERGIZED	RESULTING ACTION
RAISE	M	Motor runs; Oil flows from "B" Port, thru Ride Equalizer, thru "D" Valves to Lift Cylinders
LOWER	B,C,& D	"B,C,& D" Valves open, allowing oil to return from Lift Cylinders to the Reservoir
FOLD PLATFORM	M & E	Motor runs; "E" Valve shifts, Oil flows from Port "A" to the Fold Cylinder.
OPEN PLATFORM	A	"A" Valve opens, allowing oil to return from the Folding Cylinder to the Reservoir.

OIL CHANGE INSTRUCTIONS

NOTE:

Determine if your unit is Gravity Down or Power Down before choosing the method of oil change.

GRAVITY DOWN UNITS

1. Place an empty 3 Gallon Container under the Drain Plug.
2. Remove the Drain Plug and activate the switch to “Lower” the unfolded Platform
3. Replace the Drain Plug. Remove the Filler/Breather Cap and fill the Reservoir to within 1” from the top.
4. Replace the Filler/Breather Cap.

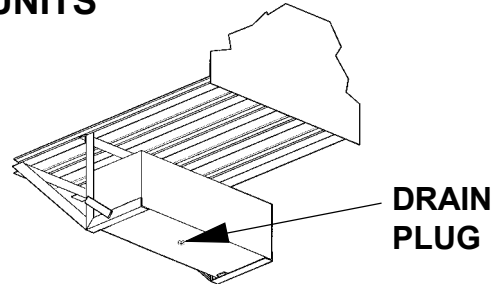

POWER DOWN UNITS

1. Place an empty 3 Gallon Container under the Drain Plug.
2. Raise the Platform and remove the Drain Plug.
3. Remove the “White Wire” from the Motor Solenoid and activate the switch to “Lower” the Platform.
4. Replace the Drain Plug and White Wire. Remove the Filler/Breather Cap and fill the Reservoir to within 1” from the top.
5. Replace the Filler/Breather Cap.

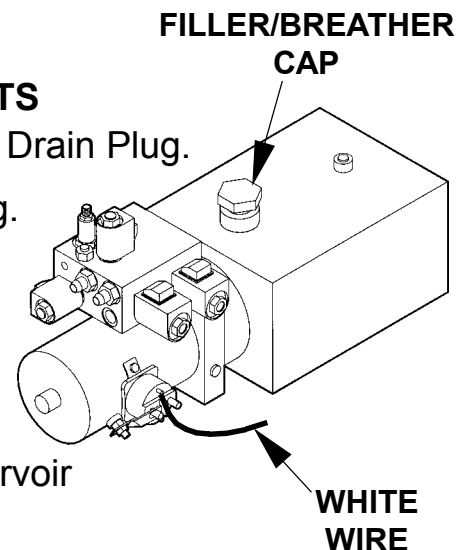

OIL SPECIFICATIONS

Grade ISO - (32)
Gravity, API - 29.5 Degrees
Pour Point, F - (-54 Degrees)
VISCOSITY
@ 40 Degrees C - 31.2 cSt
@ 100 Degrees C - 6.2 cSt
VISCOSITY INDEX - 154 VI
Flash Point, F - 325 Degrees

SOLENOID CHECK

To check the Solenoids for power, hold a screwdriver approximately 1/4" from the top nut of the Solenoid and energize the unit. If the Solenoid is good, it will draw the screwdriver to the nut through a magnetic force.

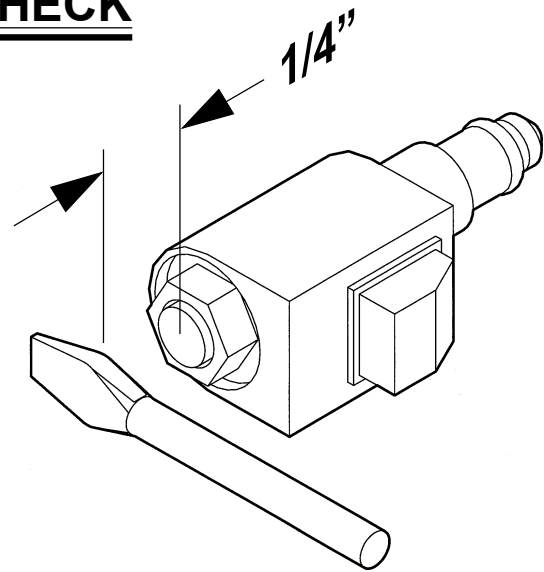

To check the valve itself, remove the Valve Coil from the Valve Cartridge. Using a paper clip, push on the Plunger inside the Valve Cartridge. It should move freely approximately 1/8\".

Inspect O-Ring and wash the Cartridge in solvent to remove any foreign substances inside the Cartridge. If Plunger still does not move freely (approx. 1/8\"), then replace the Valve Cartridge.

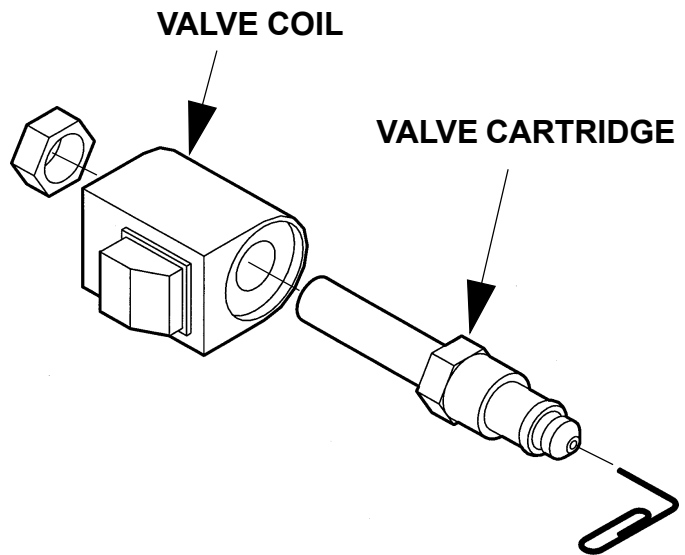

To check the Motor Solenoid for power, place a 12 volt test lamp on the Solenoid Battery Terminal.

**BATTERY CABLE
TERMINAL**

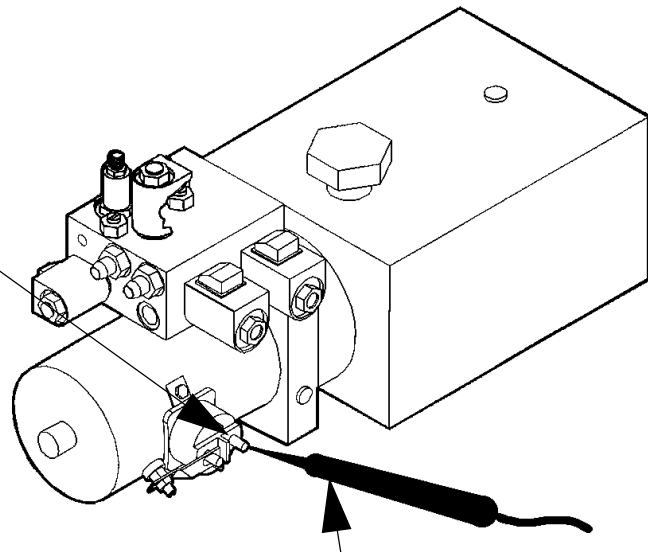

12 VOLT TEST LAMP

MAXON

11921 Slauson Ave. Santa Fe Springs, CA. 90670 (800) 227-4116 FAX (888) 771-7713

SWITCH AND HARNESS REPLACEMENT

Remove the existing Harness/Switch Assembly and replace it with the 3-Piece Cable Assembly as shown.

The first piece of cable runs from inside the Runner Switch to the bottom of the Runner. The second piece of cable runs from the bottom of the Runner, through the Spring Guard and out through the bottom of the Column. The third piece of cable runs through the channel inside the Column, over the top, and out the bottom of the Column to the Pump Box.

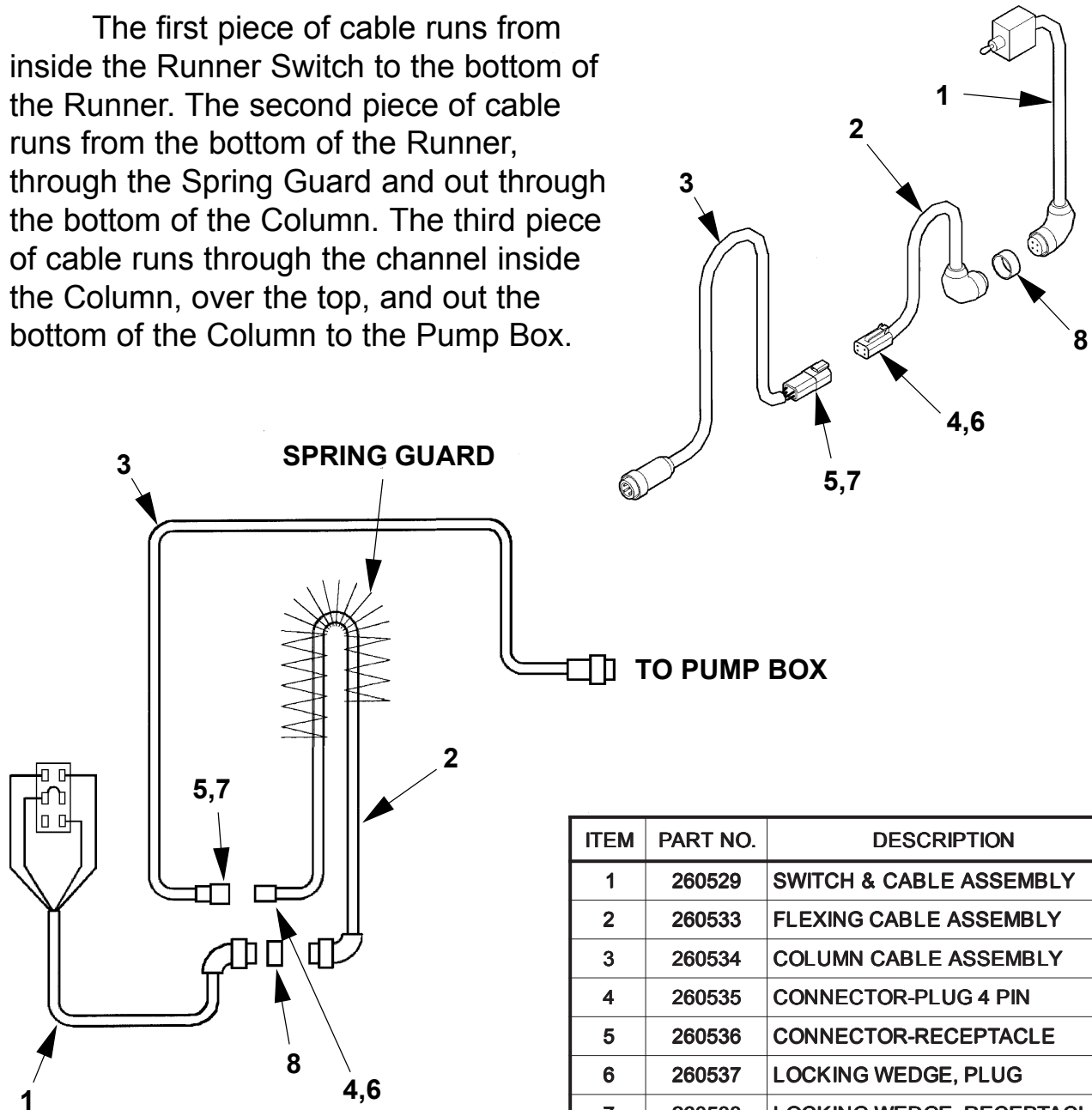

ITEM	PART NO.	DESCRIPTION
1	260529	SWITCH & CABLE ASSEMBLY
2	260533	FLEXING CABLE ASSEMBLY
3	260534	COLUMN CABLE ASSEMBLY
4	260535	CONNECTOR-PLUG 4 PIN
5	260536	CONNECTOR-RECEPTACLE
6	260537	LOCKING WEDGE, PLUG
7	260538	LOCKING WEDGE, RECEPTACLE
8	253793	ADAPTER, ALL-THREAD
*9	260875	DT REMOVAL TOOL

* NOT SHOWN

SWITCH AND HARNESS REPLACEMENT

MAXON[®]

11921 Slauson Ave. Santa Fe Springs, CA. 90670 (800) 227-4116 FAX (888) 771-7713

1. Lower the Platform to the ground. Remove the Tear Drop Assembly and the Cover from the curb side Column.

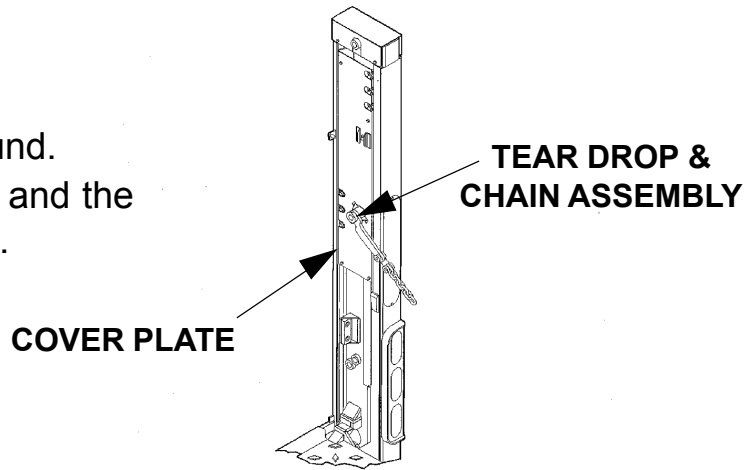

2. Remove the Switch Plate from the Runner Assembly, and remove the wires from the Switch. Attach a rope or cable (at least 20 ft. in length) to the end of the wires from the Switch. This will become the "Fishing Rope", and will be used to pull the new cable through the same route as the original wiring.

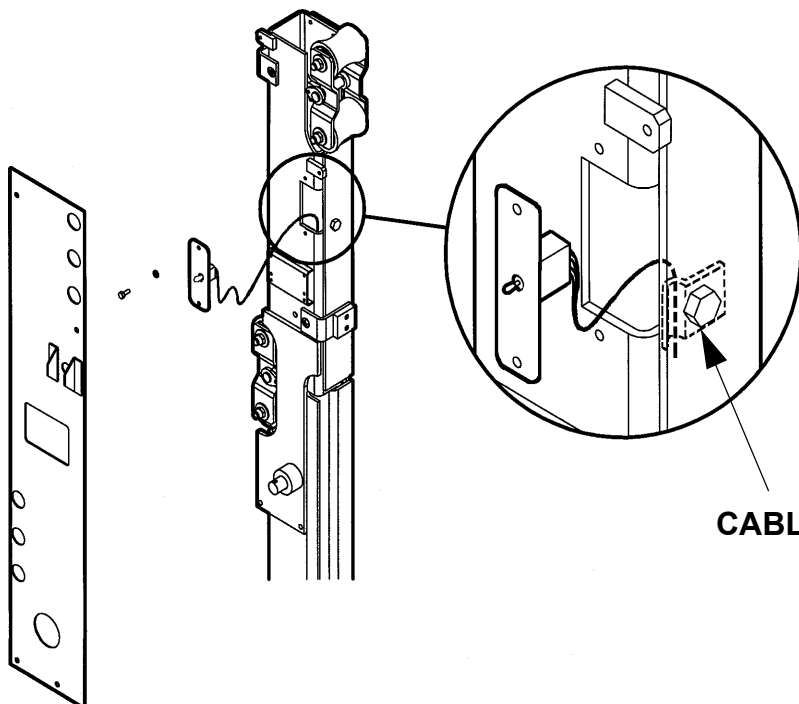
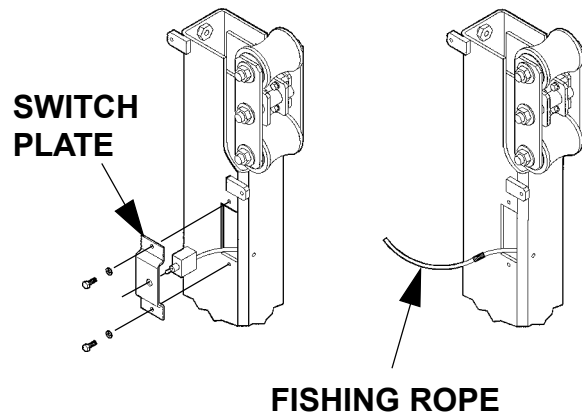

3. Located inside the Switch Mounting hole is a cable clamp. Loosen, but do not remove the nut that fastens the clamp to the Runner Assembly.

SWITCH AND HARNESS REPLACEMENT

4. Remove the fitting from the lower port of the Closing Cylinder. Remove the opposite end of the hose from the bottom of the Column. Remove the two bolts that secure the Spring Guard to the unit. One is located at the bottom of the Column, the other is located between the bottom two coils of the Spring Guard. This will also remove a cable clamp. Set these aside for re-assembly. The Spring Guard, Hose Assembly, and Cable should pull out as one unit. Pull down on the cable inside the Runner until the *fishing rope* is exposed.

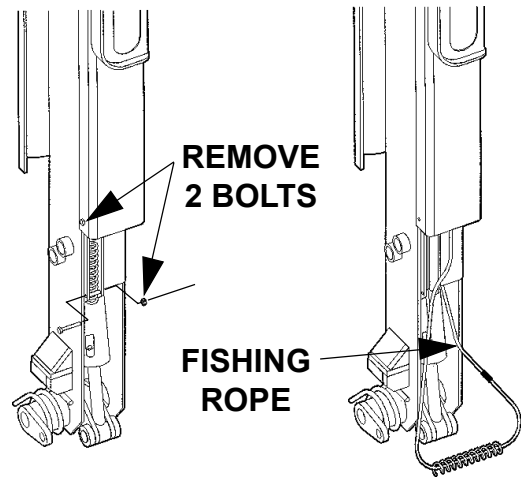

5. Remove the cable from the *fishing rope* and attach the Switch and Cable Assembly (P/N 260529 less the Switch), to the *fishing rope*. Pull the rope back up through the Runner and out the Switch Mounting hole until the cable is exposed. Leaving enough slack in the cable to wire the Switch properly, tighten the cable clamp located just inside the Switch Mounting hole and re-wire the Switch per the diagram below. Re-assemble the Switch Plate and Cover Plate. Attach the *fishing rope* to the exposed end of the cable.

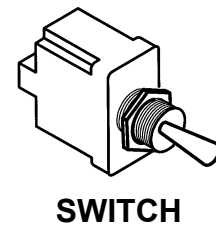
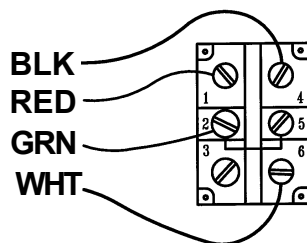
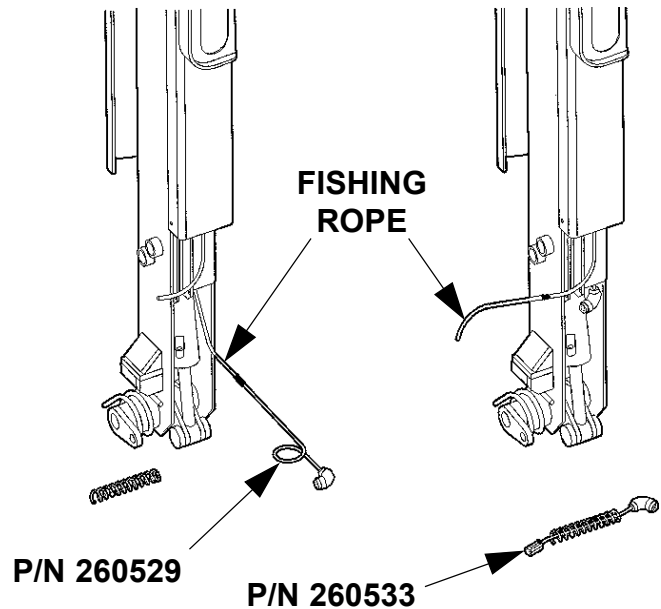

SWITCH AND HARNESS REPLACEMENT

MAXON[®]

11921 Slauson Ave. Santa Fe Springs, CA. 90670 (800) 227-4116 FAX (888) 771-7713

6. Remove the middle light from a 3 light Column, or the top light on a 2 light Column. Inside the light mounting hole near the top, loosen but do not remove the nut that fastens the clamp to the Column, so that the cable will slide freely through the clamp.

7. Remove the Cover from the top of the Column. Pull the side of the harness attached to the fishing rope in an upward direction until the splice is exposed. Move to the ground and continue pulling the harness in a downward direction until the splice is again exposed.

Remove the old cable and attach the Column Cable Assembly (P/N 260534 less the Connector-Receiver). Pull the new cable through in reverse order. Replace the Cover on the Column. Tighten the clamp in the light mounting hole and replace the Light.

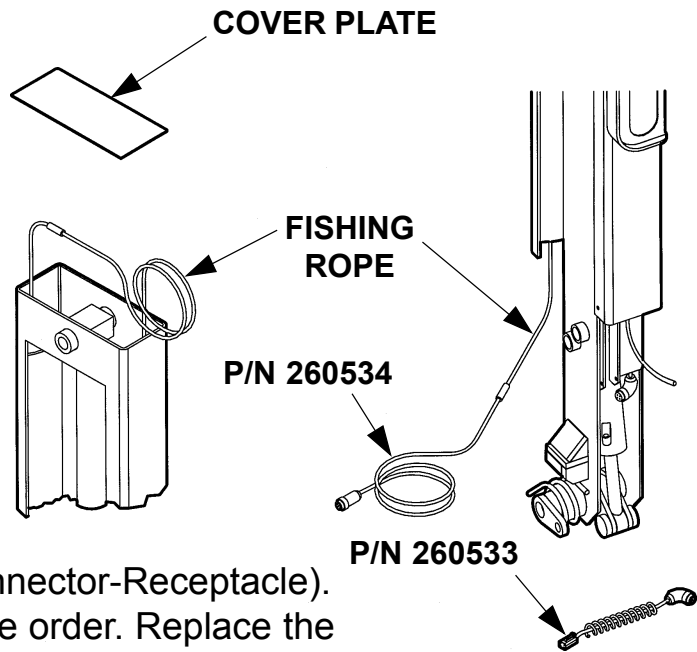

8. Place the Flexing Cable Assembly (P/N 260533), and the Closing Cylinder Hose through the Spring Guard. **NOTE:** Be sure the Flexing Cable is located on the Platform side of the Spring Guard, and is parallel, not twisted with the hydraulic hose.

Replace the Spring Guard in the Runner Channel with the bolts, clamp and plastic tube that was removed earlier. After attaching the Switch Cable to the Flexing Cable, pull the Connector-Plug end of the Flexing Cable snug through the top of the Spring Guard. Tighten the clamp that secures the Spring to the Runner. Replace the Closing Cylinder hose and make the proper connections for the Flexing Cable and the Column Cable.

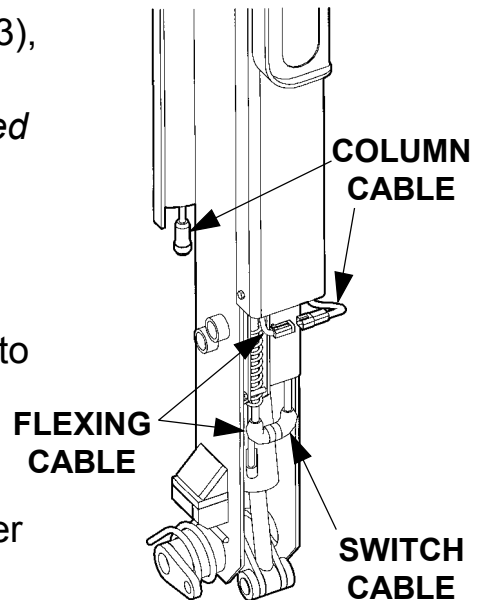

SWITCH AND HARNESS REPLACEMENT

INSTALLATION OF CONTACTS

Use the DT Removal Tool (P/N 260875), to pry between the lip of the Locking Wedge and the Connector Plug. Then twist, popping the Wedge free. The Locking Wedge can now be easily removed. Push the Socket Contacts through the Rear Seal of the Connector Plug until it snaps into a locked position. Place the Locking Wedge back into the original position and push it against the Connector Plug.

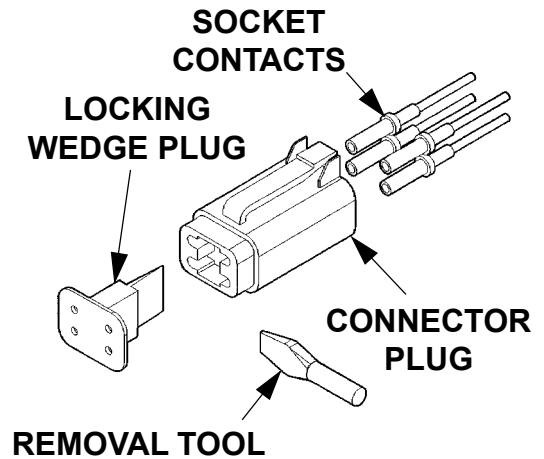

IMPORTANT!

When placing the Contacts into the plugs and receptacles, be sure the wire colors will match the mating plug or receptacle wire colors.

Slide the DT Removal Tool (P/N 260875), into the center slot of the Locking Wedge. Rotate the Removal Tool to grab the Wedge from the inside and pull out with a sharp tug. The Locking Wedge can now be easily removed. Push the Socket Contacts through the Rear Seal of the Connector Plug until it snaps into a locked position. Place the Locking Wedge back into the original position and push it against the Connector Receptacle.

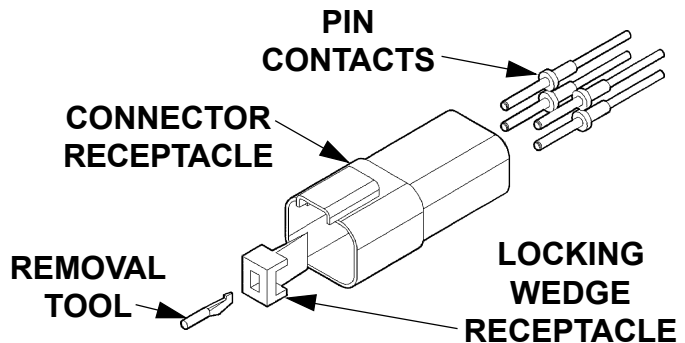

REMOVAL OF CONTACTS

After removing the Locking Wedge of either the Plug or the Receptacle, insert the DT Removal Tool between the Contacts and the Locking Finger. Gently push the Locking Finger away from the Contact while pulling the Contact and wire free from the rear.

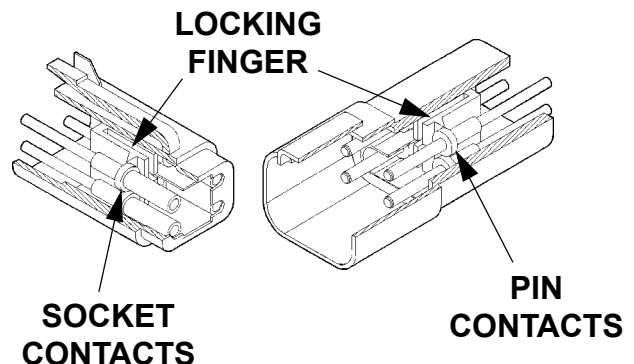

MAXON[®]

11921 Slauson Ave. Santa Fe Springs, CA. 90670 (800) 227-4116 FAX (888) 771-7713

TROUBLESHOOTING

PLATFORM WILL NOT RAISE, MOTOR WON'T RUN

1. Check the Pump Motor Solenoid for 12 Volts of power from the battery. If there is no power to the Solenoid, check the Battery Cables for damage, and the Battery for a charge. Replace or recharge as needed.

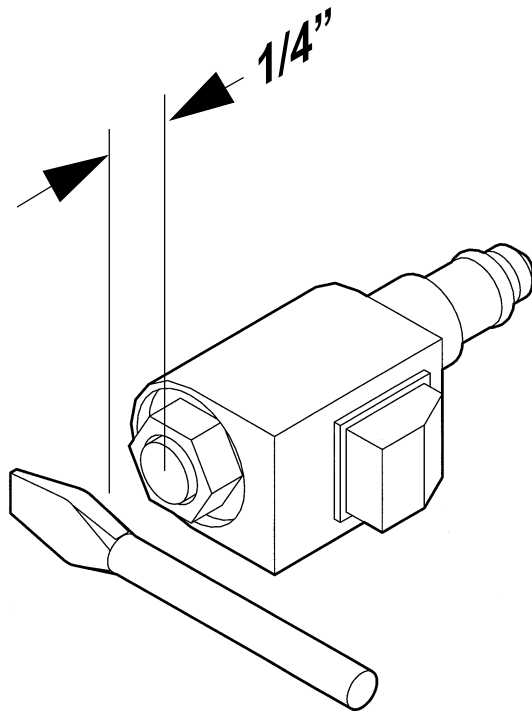
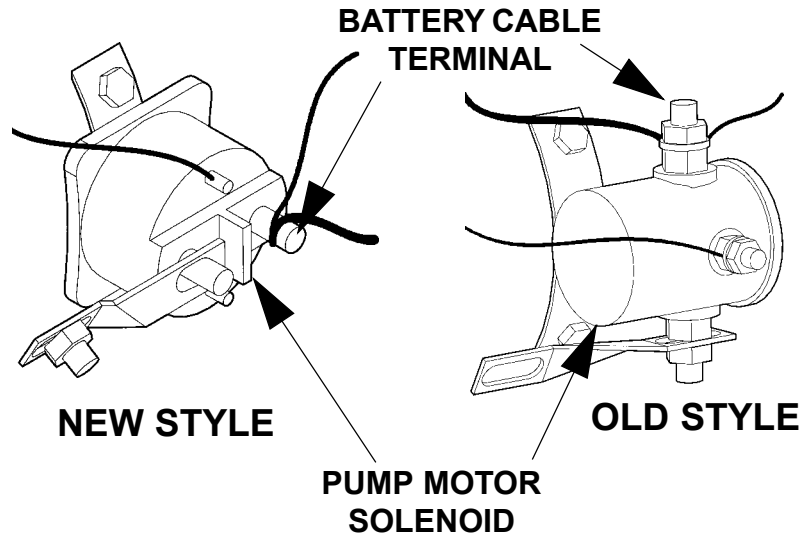

**SCREWDRIVER WILL BE
MAGNETICALLY PULLED TO
AN ENERGIZED SOLENOID**

2. Check the Solenoids in the Pump Box and Columns for power. With the control switch activated in the "UP" position, only the Pump Motor Solenoid should be energized. If any other Solenoid is energized while in the "UP" mode, there is damaged or improper wiring in the Solenoids, Control Box, or Switches. Disconnect the Runner Switch electrical cable (4-Pin Connector), from the Control Box and activate the "UP" switch mounted outside the vehicle. If the platform raises, then the short is in the Runner Switch Cable.

3. Check for structural damage to the liftgate. Visually inspect for improper bending of structures that could prevent normal operation.

PLATFORM WILL NOT PICK UP RATED CAPACITY

1. Check the Battery Cables for damage, and the Battery for a charge. Replace or recharge as needed. The use of a Voltage Load Tester is recommended.
2. Check for structural damage to the liftgate. Visually inspect for improper bending of structures that could prevent normal operation.
3. Check the Hydraulic Cylinders as follows:
 - GRAVITY DOWN UNITS: Lower the Platform to the ground. Remove the hose from the Top Port of each Cylinder. Raise the Platform and see if any oil sprays out of the fitting. If so, the Piston Seals are worn and need replacing.
 - POWER DOWN UNITS: Raise the Platform to bed height. Remove the hose from the Top Port of each Cylinder. Raise the Platform and see if a continuous flow of oil escapes from the fitting. If so, the Piston Seals are worn and need replacing.
4. Verify the correct Relief Valve Pressure Setting. Refer to the Relief Valve Pressure Setting page for proper procedures.

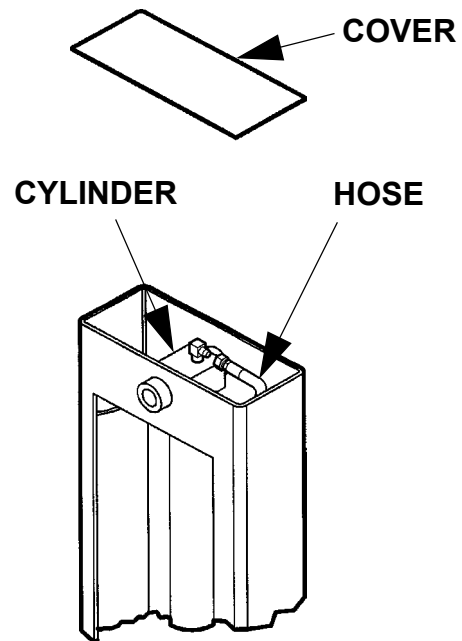

PLATFORM RAISES HALFWAY & STOPS

1. Check the hydraulic fluid level in the Reservoir.

GRAVITY DOWN UNITS: Lower the Platform to the ground. Fill the Reservoir to about 1" from the top. Do not overfill as this causes spillage.

POWER DOWN UNITS: Raise the Platform to bed height. Fill the Reservoir to about the middle. Do not overfill as this causes spillage.

2. Check the Battery Cables for damage, and the Battery for a charge. Replace or recharge as needed. The use of a Voltage Load Tester is recommended. Check the Circuit Breaker. Reset or replace as needed.

3. Check for structural damage to the liftgate. Visually inspect for improper bending of structures that could prevent normal operation. Be sure the unit has been properly lubricated to prevent binding. Lubricate or replace worn parts.

4. A worn Pump or clogged Pump Filter can cause the unit to lift slowly. Check the Pump Filter located in the Reservoir. A worn pump will be extremely noisy. Replace as necessary.

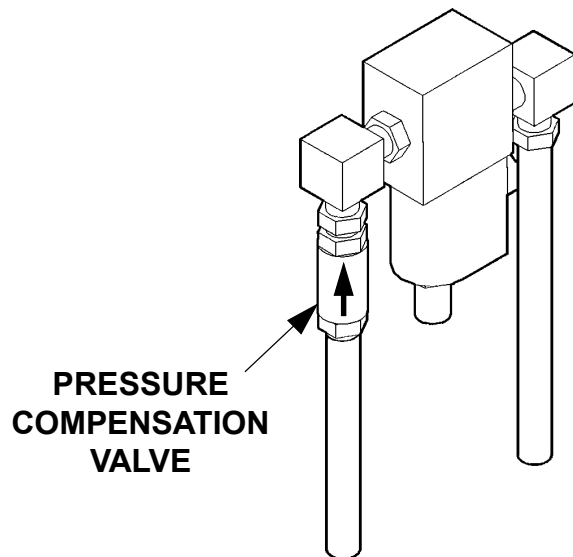
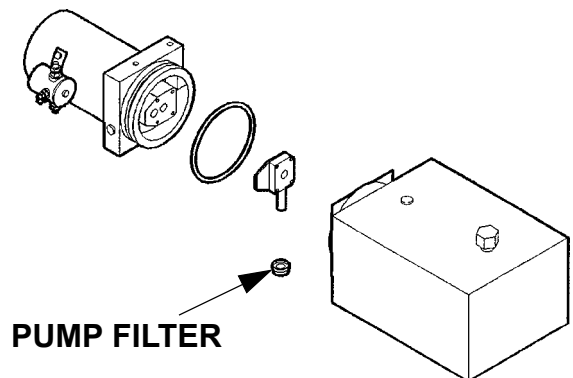

5. Check the Pressure Compensation Valves located at the top of each Column. They may be partially plugged.

PLATFORM LOWERS UNEVEN

1. Lower the Platform to the ground and remove the Pressure Compensation Valves located at the top of each Column. Disassemble and clean each valve. Reinstall, or replace as necessary using the thread Sealant Instructions on the inside back cover of this manual.

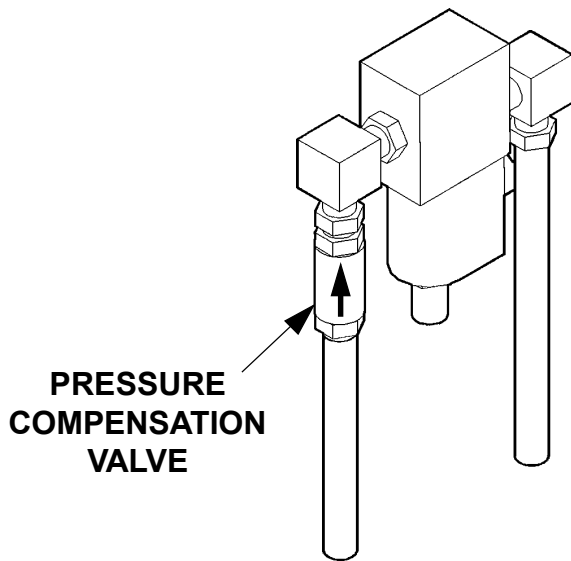

2. Drain all the Hydraulic Oil from the Reservoir. Install a Filter Kit (P/N 260578), between the “C” Valve and the Reservoir. Instructions on how to do this (M-95-27), are included in the Kit. Clean or replace the Filter if the Filter Kit is already installed.

MAXON[®]

11921 Slauson Ave. Santa Fe Springs, CA. 90670 (800) 227-4116 FAX (888) 771-7713

PLATFORM WILL NOT CLOSE

1. Check the hydraulic fluid level in the Reservoir.

GRAVITY DOWN UNITS: Lower the Platform to the ground. Fill the Reservoir to about 1" from the top. Do not overfill as this causes spillage.

POWER DOWN UNITS: Raise the Platform to bed height. Fill the Reservoir to about the middle. Do not overfill as this causes spillage.

2. Check the Motor Solenoid ("M") for power by placing a 12 Volt Test Lamp on terminal "A". If nothing registers on the Test Lamp, the Battery or Battery Cables are faulty. Check the Motor Solenoid ("M") itself by placing the 12 Volt Test Lamp on terminal "B". If nothing registers on the Test Lamp, replace the Motor Solenoid. If power does register on the Test Lamp, replace the Motor.

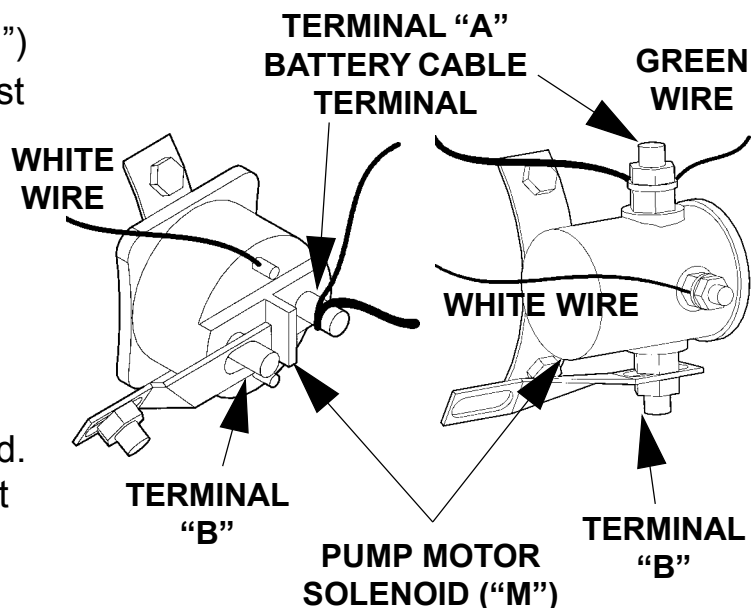

3. If the unit has an Emergency Hand Pump attached, be sure the proper valves are closed. Refer to the Decal on the Pump for proper operation.

4. Check the Flow Control Valve. This valve should be open. Adjust as necessary for speed.

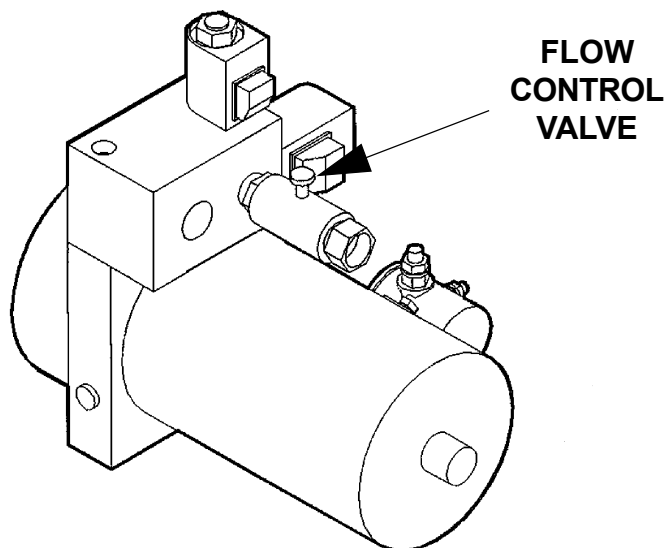

Continued Next Page

PLATFORM WILL NOT CLOSE

5. Check the "E" Valve, remove the Valve Coil from the Valve Cartridge. Using a paper clip, push on the Plunger inside the Valve Cartridge. It should move freely approximately 1/8". Inspect O-Ring and wash the Cartridge in solvent to remove any foreign substances inside the Cartridge. If Plunger still does not move freely (approx. 1/8"), then replace the Valve Cartridge.

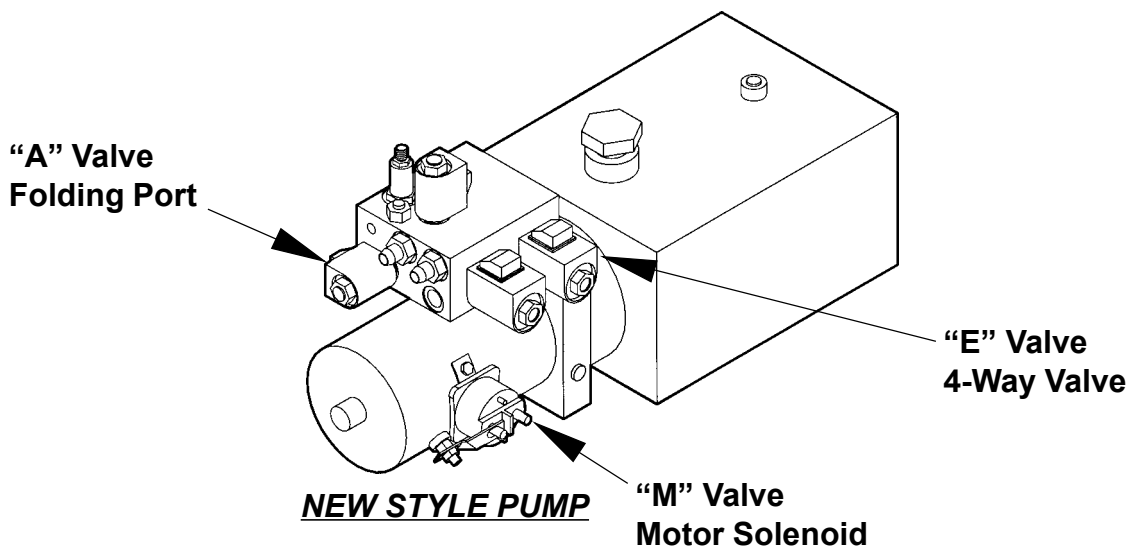
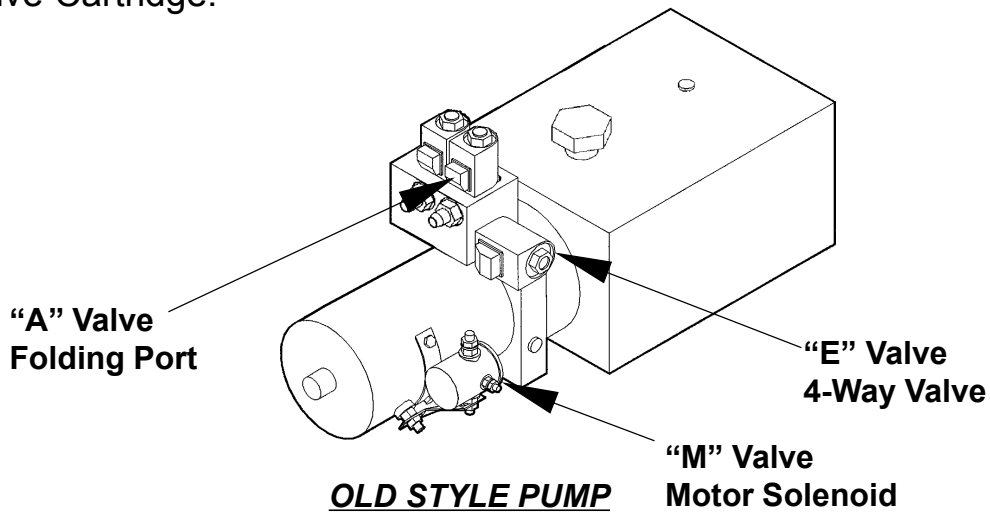
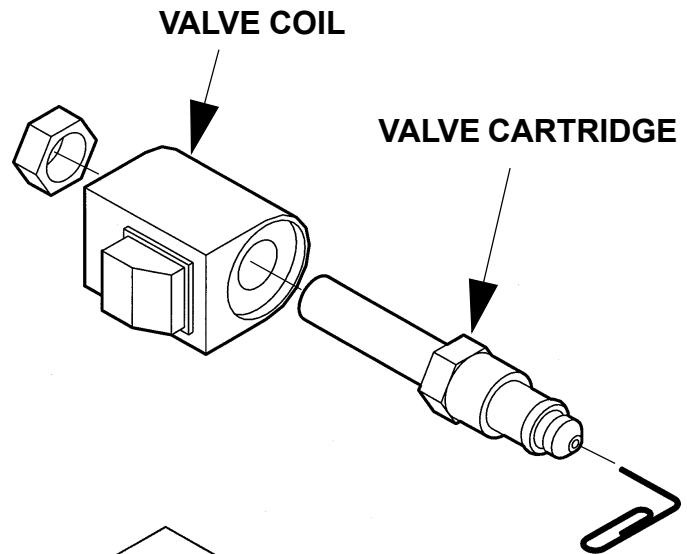

MAXON

11921 Slauson Ave. Santa Fe Springs, CA. 90670 (800) 227-4116 FAX (888) 771-7713

PLATFORM FOLDING SPEED ADJUSTMENT

OLD STYLE PUMP

1. The speed settings for the Closing Cylinder are regulated by the Flow Control Valves located on the "A" Port. Each Valve has an arrow on it indicating the direction of flow it regulates. The Valve that points away from the Pump controls the closing speed. The Valve that points toward the Pump controls the opening speed.

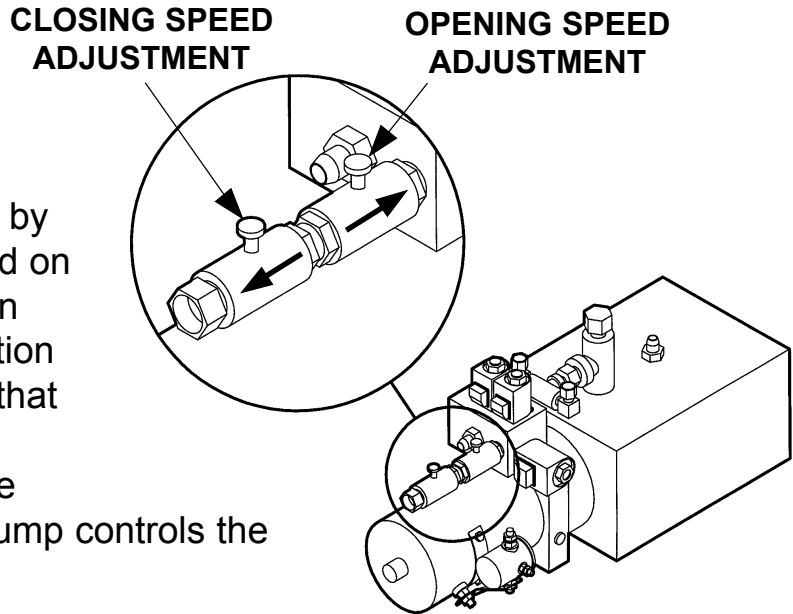

2. Turn the Valves clockwise to decrease the speed. Turn the Valves counter-clockwise to increase the speed.

NEW STYLE PUMP

1. The speed settings for the Closing Cylinder are regulated by the Pressure Relief Needle Valves located on the Manifold Block. Each Valve has either an "O" (open), or "C" (close) on it indicating the direction of flow it regulates.

2. Turn the "O" Valve clockwise to decrease the speed. Turn the "C" Valve clockwise to increase the speed.

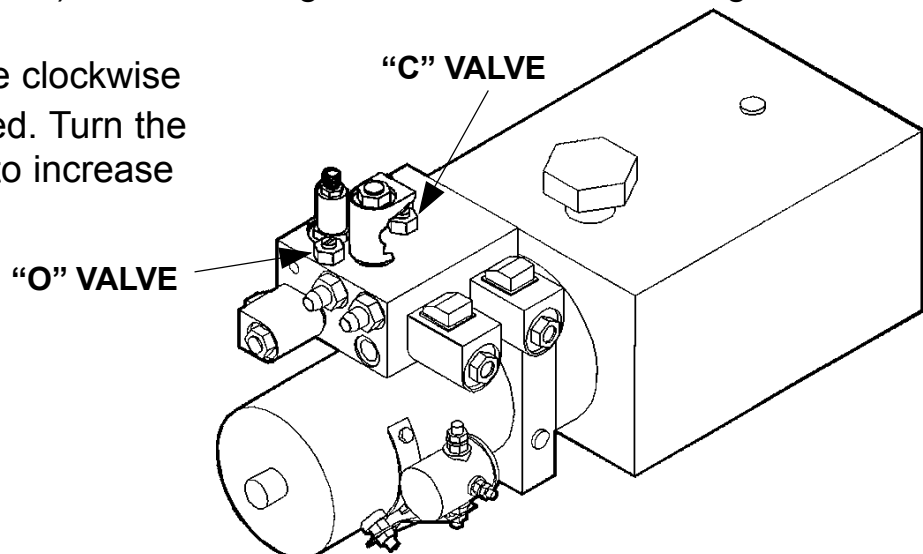

PLATFORM WILL NOT UNFOLD

1. The flow of hydraulic oil may be restricted. Check the following:
 - a. OLD STYLE PUMP, turn the "A" Port Flow Control Valve nearest the Reservoir in a counter-clockwise direction to open the valve.
 - b. NEW STYLE PUMP, adjust the "O" Pressure Relief Valve to open the valve.

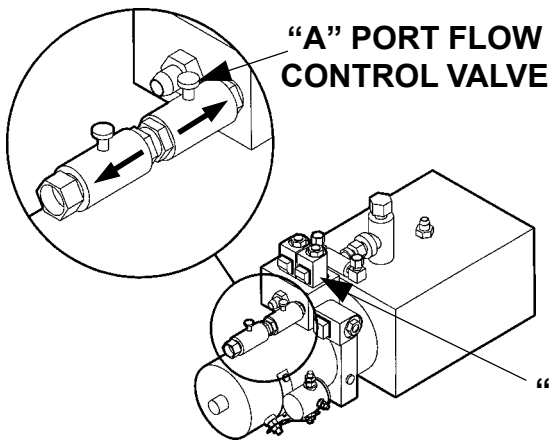

OLD STYLE PUMP

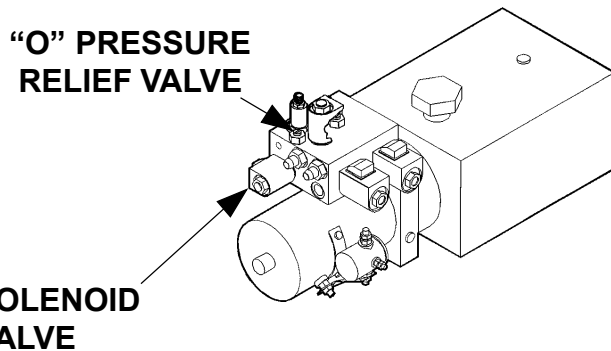

NEW STYLE PUMP

2. Check the "A" Solenoid Valve Coil for power. Place a screwdriver about 1/4" from the "A" Solenoid and energize the unit. If the screwdriver is not drawn to the energized solenoid the solenoid must be repaired or replaced.

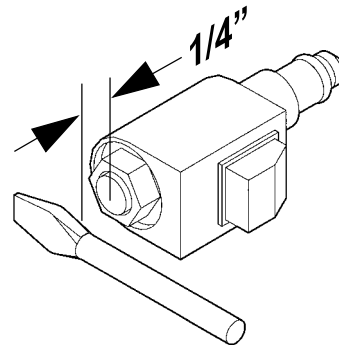

3. Remove the Valve Coil from the Valve Cartridge. Using a paper clip, push on the Plunger inside the Valve Cartridge. It should move freely approximately 1/8". Inspect O-Ring and wash the Cartridge in solvent to remove any foreign substances inside the Cartridge. If Plunger still does not move freely (approx. 1/8"), then replace the Valve Cartridge.

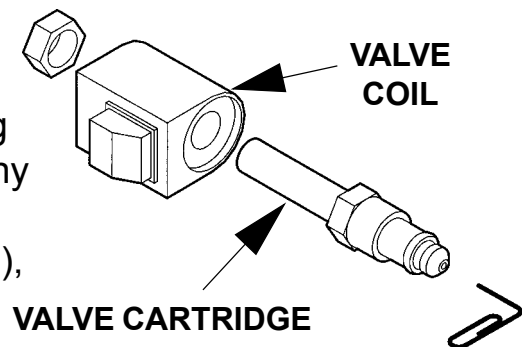

4. Check the folding pivot points for damage or corrosion. Steam clean if necessary. Replace bushings if necessary.

MAXON

11921 Slauson Ave. Santa Fe Springs, CA. 90670 (800) 227-4116 FAX (888) 771-7713

PLATFORM RAISES INSTEAD OF FOLDING

OLD STYLE PUMPS ONLY

1. Check the Pump Motor Solenoid for 12 Volts of power from the battery. If there is no power to the Solenoid, check the Battery Cables for damage, and the Battery for a charge. The use of a Voltage Load Tester is recommended. Replace or recharge as needed.

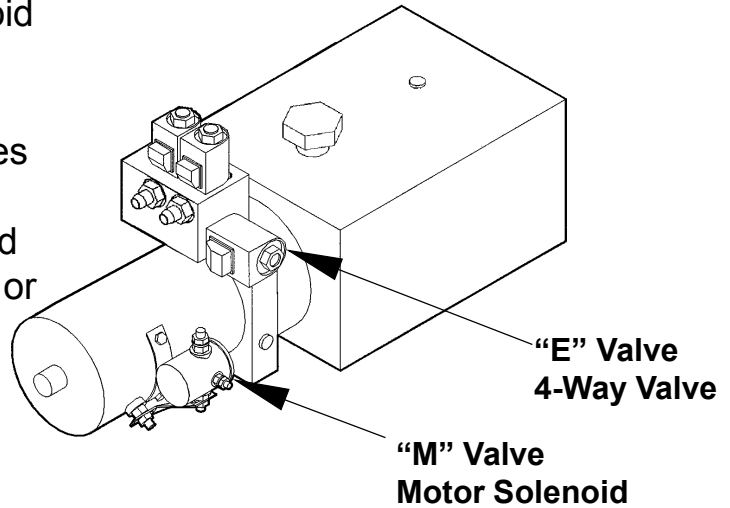
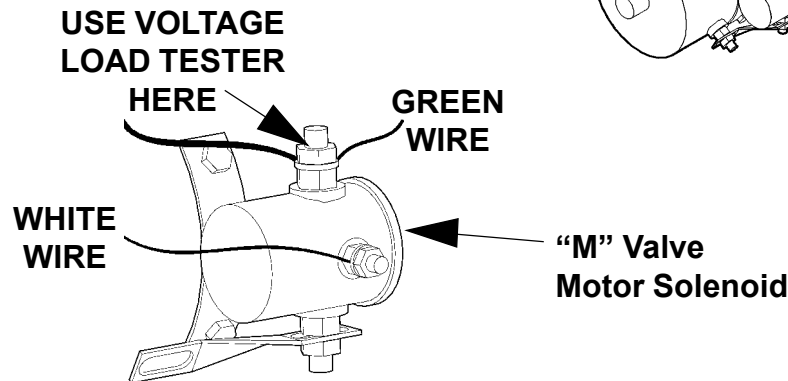

2. Check the "E" Solenoid Valve Coil for power. Place a screwdriver about 1/4" from the "E" Solenoid and activate the "FOLD" function on the switch. If the screwdriver is drawn to the energized solenoid and the unit wants to Raise instead of Fold, the solenoid must be repaired or replaced. If the "E" Valve is *not* energized during the "FOLD" operation of the switch, check the electrical connections.

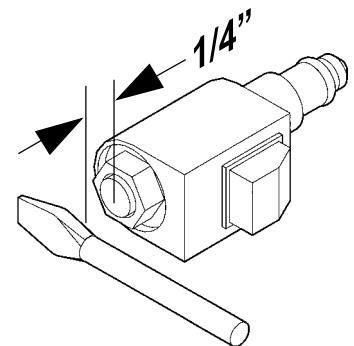

3. Disconnect the Runner Switch electrical cable (4-Pin Connector), from the Control Box and activate the "FOLD" switches mounted outside the vehicle. If the platform folds, then the short is in the Runner Switch Cable. Repair or replace the Harness.

MAXON[®]

11921 Slauson Ave. Santa Fe Springs, CA. 90670 (800) 227-4116 FAX (888) 771-7713

TROUBLESHOOTING GRAVITY DOWN

PLATFORM WILL NOT RAISE, MOTOR RUNS

1. Check the hydraulic fluid level in the Reservoir. Lower the opened Platform to the ground. Fill the Reservoir to about 1" from the top. Do not overfill as this causes spillage.

2. Check the Relief Valve for contamination or defective operation. Lower the Platform to the ground.

OLD STYLE PUMP: Check the "C" Valve to see if it is stuck in the open position. Place a screwdriver about 1/4" from end of solenoid. It should be magnetically drawn to the Solenoid only when the switch is activated in the "DOWN" position. Remove the "C" Valve body and clean or replace as necessary. Remove the Relief Valve and clean or replace.

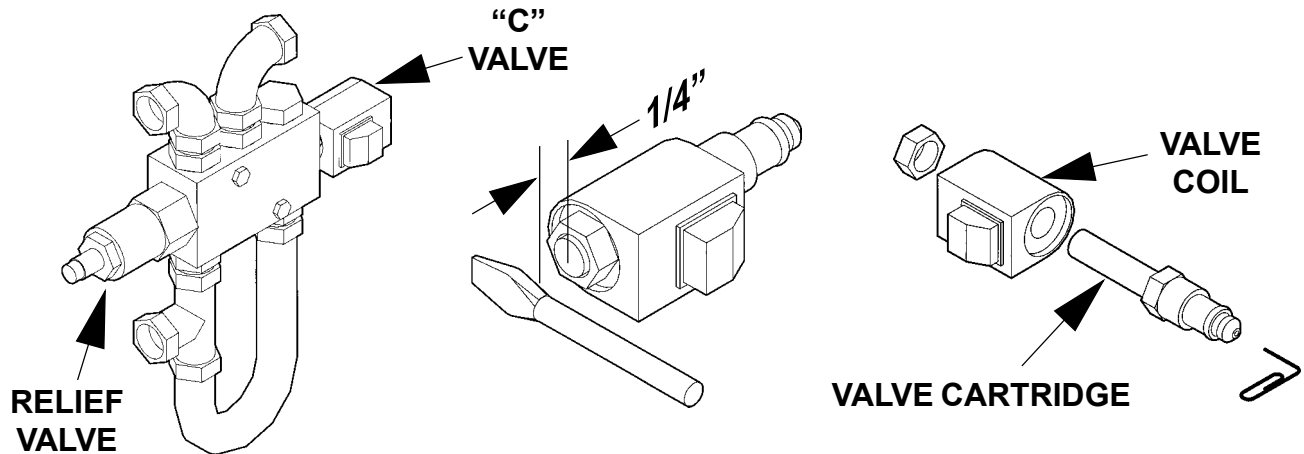

NEW STYLE PUMP: Remove the Relief Valve and clean or replace.

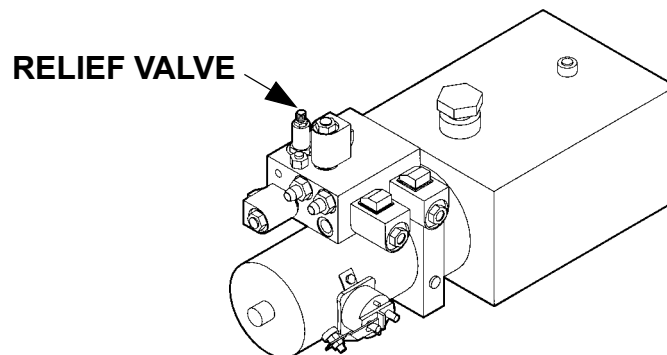

3. Adjust the pressure per the "Relief Valve Pressure Setting" page.

PLATFORM WILL NOT LOWER

1. Check the Battery Cables for damage, and the Battery for a charge. Replace or recharge as needed. The use of a Voltage Load Tester is recommended.
2. Check the two "D" Solenoid Valve Coils (located at the top of each Column), and the "B" and "C" Valve Coils (located in the Pump Box), for power.

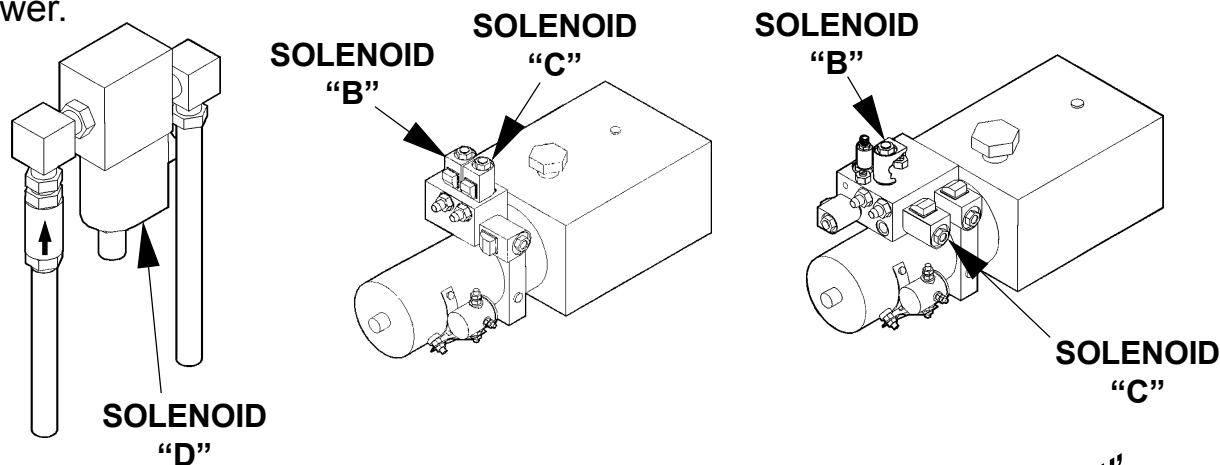

Place a screwdriver about 1/4" from the Solenoid and energize the unit. If the screwdriver is not drawn to the energized solenoid the solenoid must be repaired or replaced.

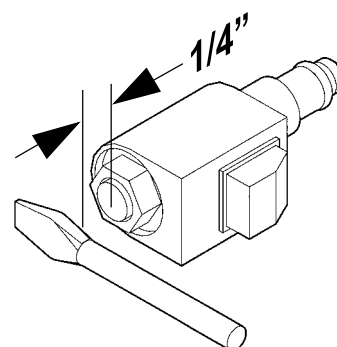

3. To clean the Valve, remove the Valve Coil from the Valve Cartridge. Using a paper clip, push on the Plunger inside the Valve Cartridge. It should move freely approximately 1/8". Inspect O-Ring and wash the Cartridge in solvent to remove any foreign substances inside the Cartridge. If Plunger still does not move freely (approx. 1/8"), then replace the Valve Cartridge.

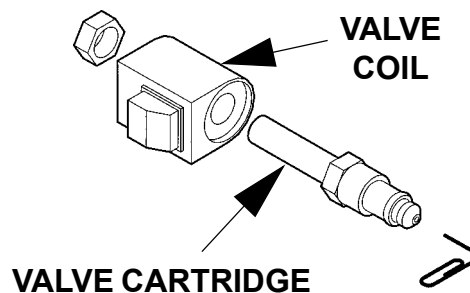

MAXON

11921 Slauson Ave. Santa Fe Springs, CA. 90670 (800) 227-4116 FAX (888) 771-7713

PLATFORM LOWERS SLOWLY

1. Check the “B” and “C” Valve Coils (located in the Pump Box), for power. Place a screwdriver about 1/4” from the Solenoid and energize the unit. If the screwdriver is not drawn to the energized solenoid the solenoid must be repaired or replaced.

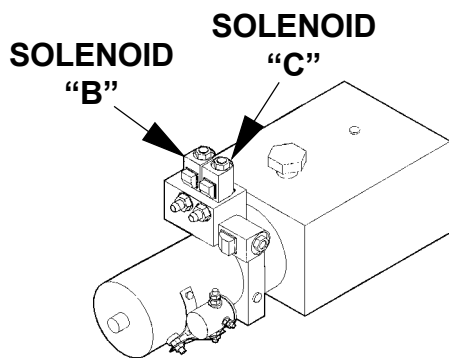

OLD STYLE PUMP

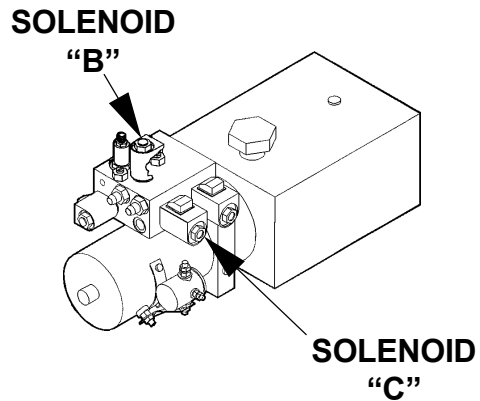

NEW STYLE PUMP

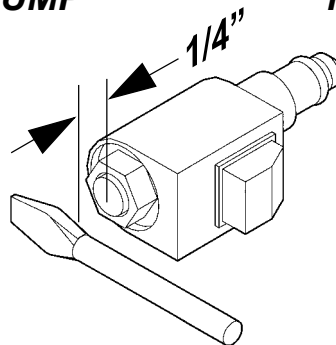

2. To clean the Valve, remove the Valve Coil from the Valve Cartridge. Using a paper clip, push on the Plunger inside the Valve Cartridge. It should move freely approximately 1/8”. Inspect O-Ring and wash the Cartridge in solvent to remove any foreign substances inside the Cartridge. If Plunger still does not move freely (approx. 1/8”), then replace the Valve Cartridge.

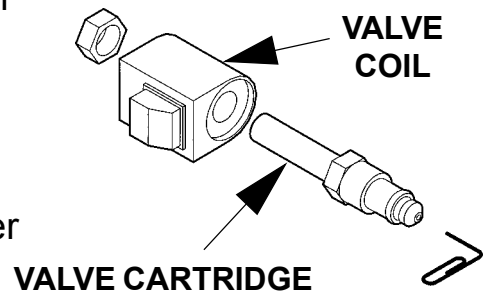

3. Check the Pressure Compensation Valves. (Ref. Platform Lowers Uneven)

MAXON[®]

11921 Slauson Ave. Santa Fe Springs, CA. 90670 (800) 227-4116 FAX (888) 771-7713

TROUBLESHOOTING POWER DOWN

PLATFORM WILL NOT RAISE, MOTOR RUNS

1. Raise the Platform to bed height. Fill the Reservoir to about the middle. Do not overfill as this causes spillage.
2. The Motor Solenoid (“M”) Valve should be the only solenoid energized during the “RAISE” function. Verify that no other Solenoid is energized.
3. The 4-Way Solenoid Valve may be stuck in the “open” position.
OLD STYLE PUMPS: Verify that the “F” Solenoid Valve is not energized during the “RAISE” function. Remove the “F” Solenoid Valve Body and clean.

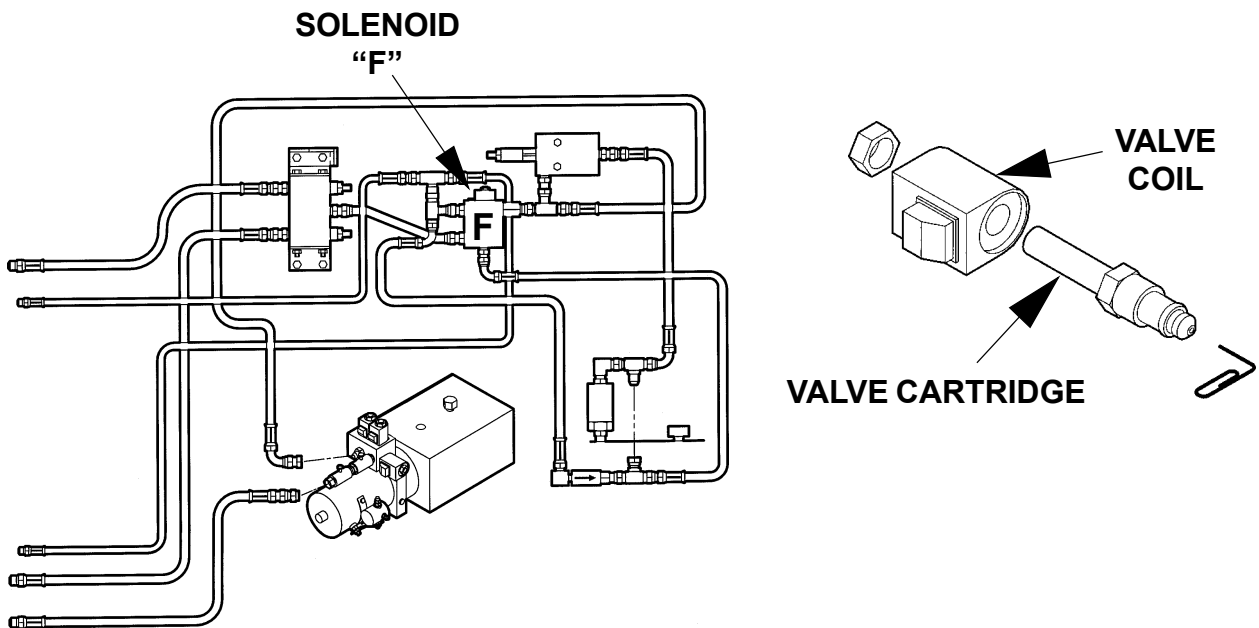

To clean the Valve, remove the Valve Coil from the Valve Cartridge. Using a paper clip, push on the Plunger inside the Valve Cartridge. It should move freely approximately 1/8". Inspect O-Ring and wash the Cartridge in solvent to remove any foreign substances inside the Cartridge. If Plunger still does not move freely (approx. 1/8"), then replace the Valve Cartridge.

NEW STYLE PUMPS: Verify that the “C” Solenoid Valve is not energized during the “RAISE” function. Remove the “C” Solenoid Valve Body and clean.

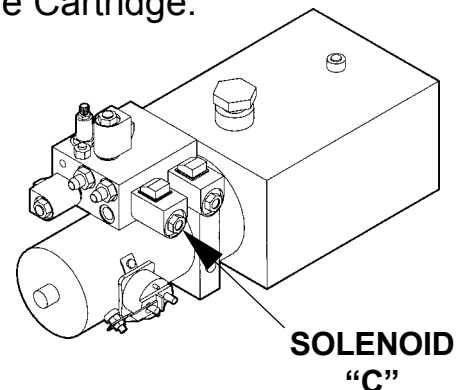

PLATFORM WILL NOT LOWER

1. Check the Battery Cables for damage, and the Battery for a charge. Replace or recharge as needed. The use of a Voltage Load Tester is recommended.

2. Check the following Solenoids for power: the two "D" Solenoid Valve Coils (located at the top of each Column), the "M" Motor Solenoid Valves, and the "4-Way" Solenoid Valves (located in the Pump Box).

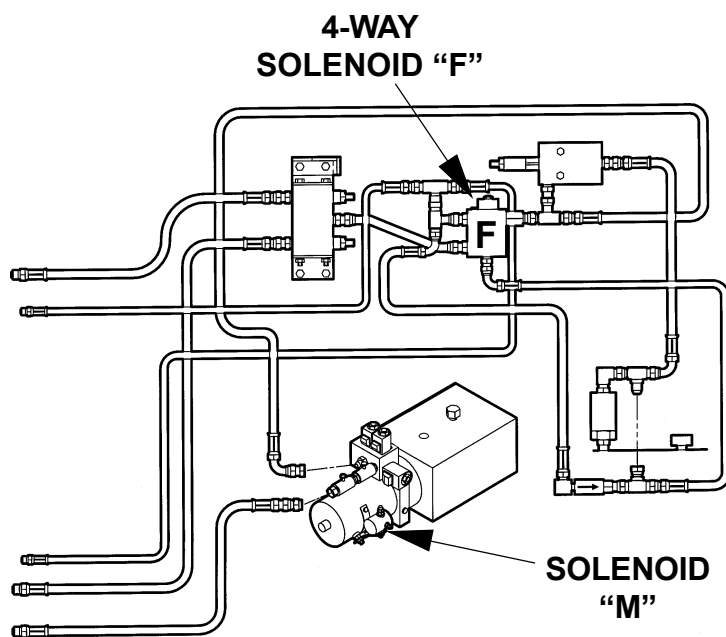
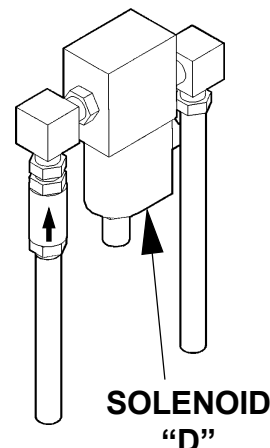

OLD STYLE PUMP

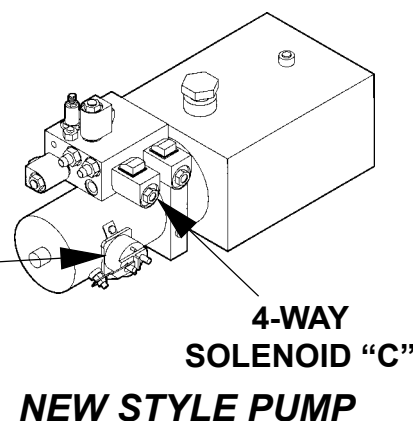

NEW STYLE PUMP

3. To clean the Valve, remove the Valve Coil from the Valve Cartridge. Using a paper clip, push on the Plunger inside the Valve Cartridge. It should move freely approximately 1/8". Inspect O-Ring and wash the Cartridge in solvent to remove any foreign substances inside the Cartridge. If Plunger still does not move freely (approx. 1/8"), then replace the Valve Cartridge.

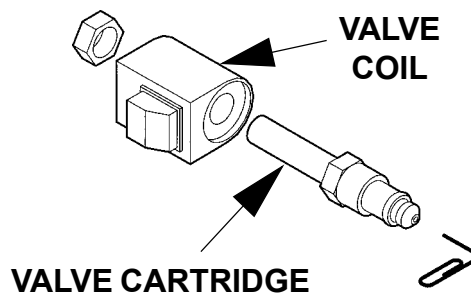

MAXON

11921 Slauson Ave. Santa Fe Springs, CA. 90670 (800) 227-4116 FAX (888) 771-7713

PLATFORM LOWERS SLOWLY

1. Check the "M" Motor Solenoid Valves, and the "4-Way" Solenoid Valves (located in the Pump Box), for power.

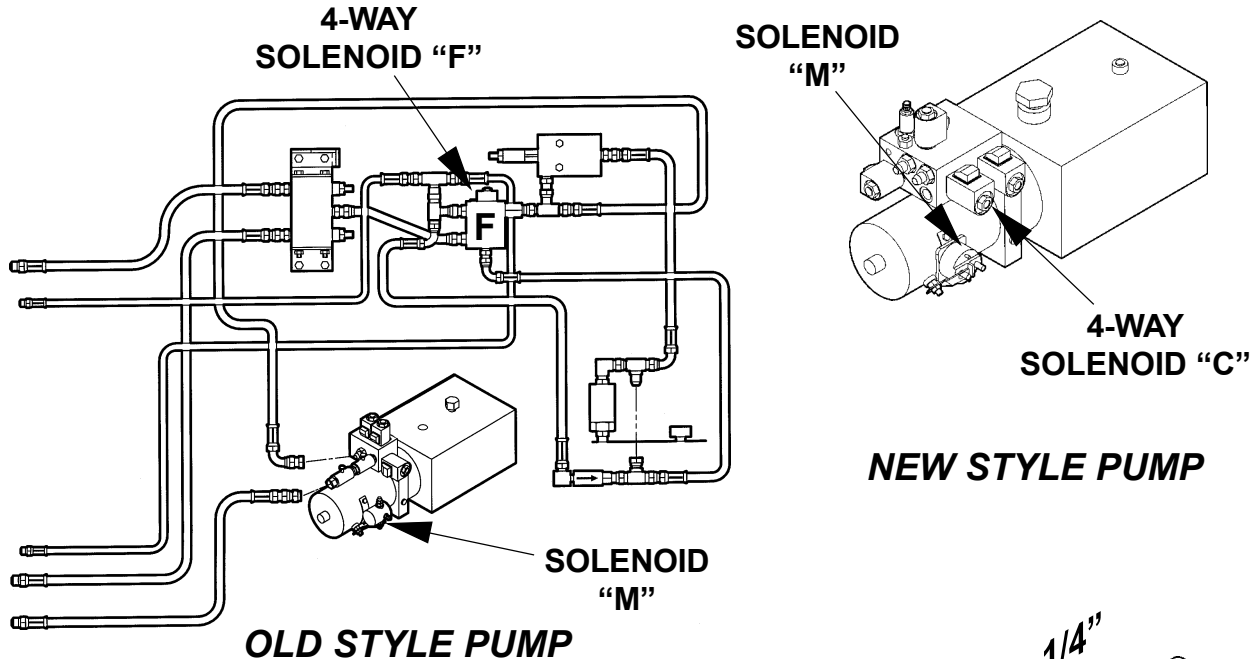

2. Check the Solenoid Valve Coil for power. Place a screwdriver about 1/4" from the Solenoid and energize the unit. If the screwdriver is not drawn to the energized solenoid the solenoid must be repaired or replaced.

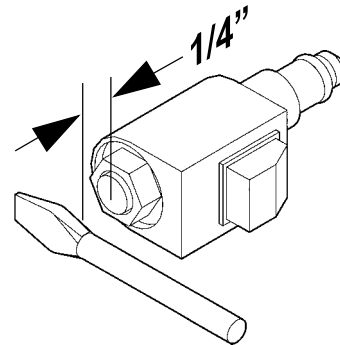

3. To clean the Valve, remove the Valve Coil from the Valve Cartridge. Using a paper clip, push on the Plunger inside the Valve Cartridge. It should move freely approximately 1/8". Inspect O-Ring and wash the Cartridge in solvent to remove any foreign substances inside the Cartridge. If Plunger still does not move freely (approx. 1/8"), then replace the Valve Cartridge.

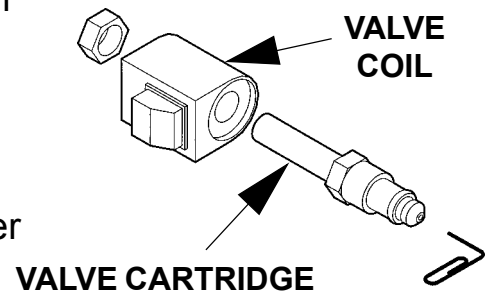

4. Check the Pressure Compensation Valves. (Ref. Platform Lowers Uneven)

LIQUID SEALANT APPLICATION

1. Clean all threads with a soft brush and a suitable cleaning solvent.
2. Dry threads thoroughly with compressed air or shop towel.
3. Apply the Liquid Sealant (Compound PLS 2), to the external threads of the Male Connector.
4. Assemble the fitting and torque it to the prescribed value.
5. Check for leakage. If leakage exists, remove the fitting and return to Step # 1.
6. If fitting is loosened or removed, return to Step # 1.

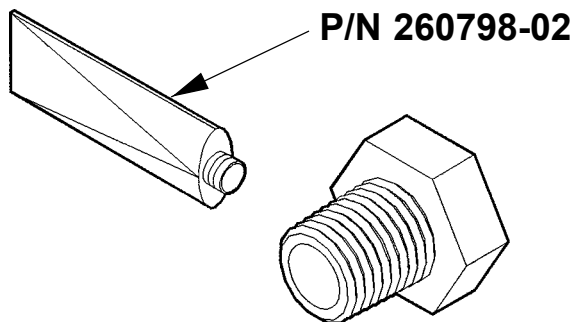

CAUTION

Due to the 80% lead content in PLS 2, follow these safety and first aid precautions:

Eye Contact - Flush eyes immediately with large quantities of water, lifting the upper and lower eyelids occasionally. If irritation persists, consult a physician.

Skin Contact - Flush the contaminated skin and wash with soap and water.

Ingestion - If person is conscious, give large quantities of water to drink and induce vomiting. Consult a physician immediately.