

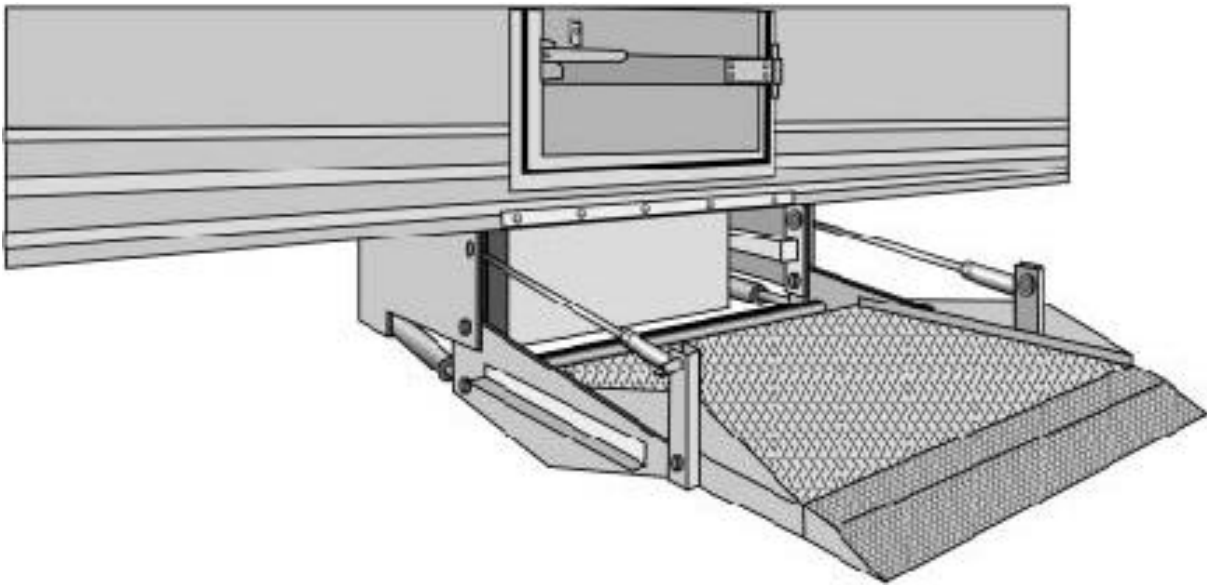

Instruction & Repair Parts Manual

TLS3500RL Hide-A-Way™ Trailer Side Gate



LEYMAN MANUFACTURING CORPORATION
10900 Kenwood Road
Cincinnati, OH 45242
1-866-LEYMAN-1 • 1-866-539-6261 • 513-891-6210
Fax 513-891-4901
www.leymanlift.com
sales@leymanlift.com

LML00085-12/04

TABLE OF CONTENTS

General Terminology	2
Operating Instructions	3
Emergency Hand Pump and Preventative Maintenance	4-5
Maintenance Minder 2	6-7
General Specifications	8
Installation Adjustments	9
Recommended Oils and Lubrication	10
Power Unit Replacement Parts	11 – 11B
Replacement Bearings and Shafts	12
Chain Area Replacement Parts	13
Emergency Hand Pump Parts	14 – 14A
Brake Lock-Up	15
Wiring and Hydraulic Diagram	16 -16B
Basic Electrics for Smart Start Solenoid	17-18C
Toggle Switch Electrics	19 - 20
Walk Around Push Button Electrics	21 - 21A
Electrical Connections	22-23A
Circuit Breaker Wiring Diagram	24
Troubleshooting Chart	25
Notes	26

GENERAL TERMINOLOGY

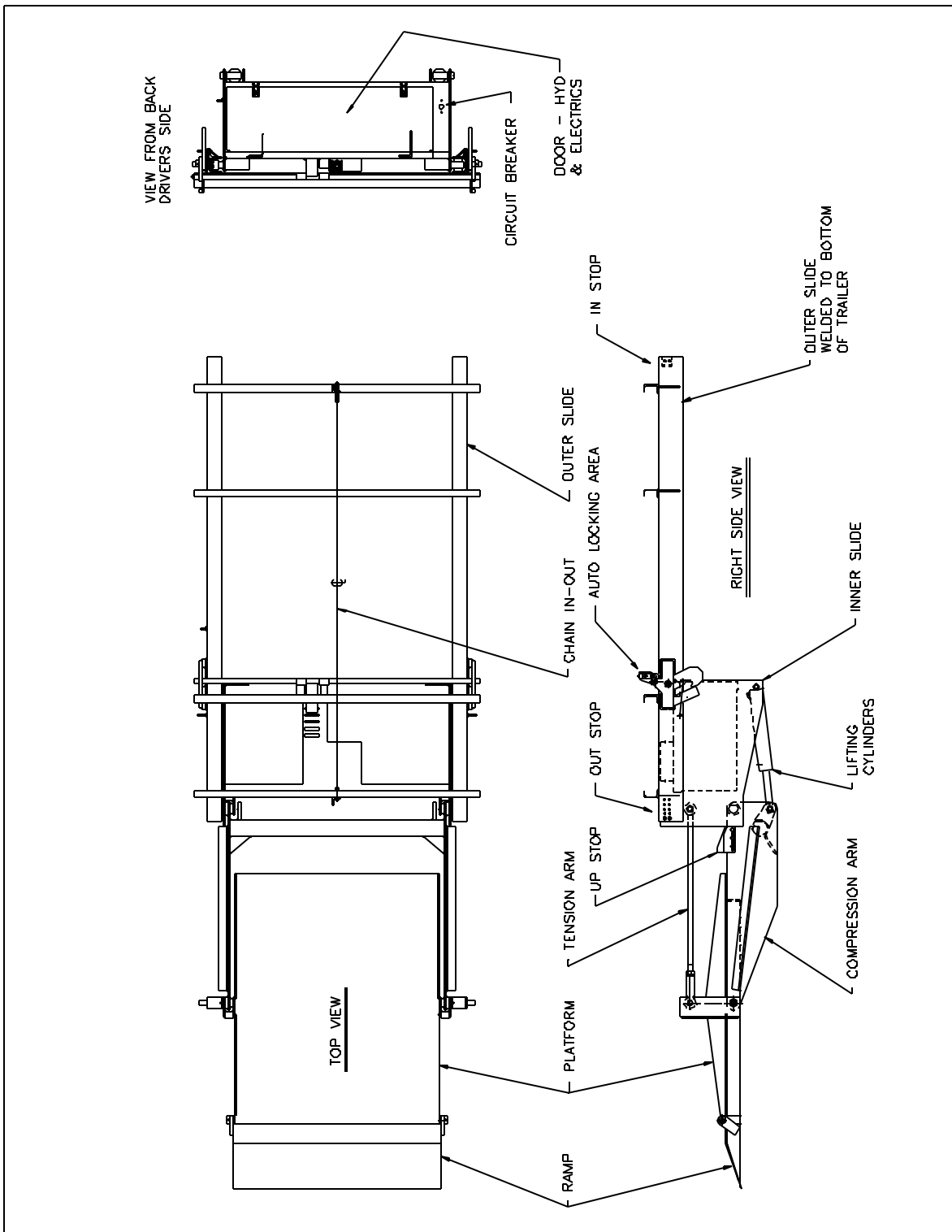

OPERATING INSTRUCTIONS

Before operating the lift gate, read and understand this manual and all urgent warning decals.

Do not stand in front of the lift gate while unfolding or using the platform.

With the gate in the over-the-road (stored) position, proceed with the following steps:

1. To relieve the tension on the auto lock, push the up switch (the gate will go up), pull the handle to release the auto lock.
2. Use the down switch to lower the lift until arms are parallel to the ground.
3. Stand to the side of the lift gate. Push the power in/out switch down. Gate will run out. Run the gate out until it stops and locks into its fully extended position.
4. Unfold the ramp.

To lower the platform, use the down switch only.

To raise the platform, use the up switch only.

To store the gate in the over-the-road (stored) position:

1. Raise the platform off the ground until the arms are parallel to the ground.
2. Fold ramp over.
3. Raise locking bar handle and push the in/out switch upward. Run the gate all the way under the trailer until the lift stops.
4. Run gate up (use the up switch). The auto lock will latch.
5. Lower the gate until resting on the auto lock. Use the down switch only.

EMERGENCY HAND PUMP OPERATION

If an emergency hand pump was supplied with this lift gate its intended use is to restore the gate to the transit position.

CAUTION: Do not try to operate the power unit when using the hand pump.

Steps to secure the gate, so the trailer can be moved:

1. Remove the pump handle from the holder and insert into the hand pump socket.
2. Raise the platform off the ground about 6", pump up/down.
3. Retract the gate, disconnect the in/out chain and manually push the gate under the trailer all the way until it stops.
4. Pump the gate until fully up.
5. With the handle unscrew the valve on the bottom of the hand pump. This will let the gate down into its over the road position.

PREVENTATIVE MAINTENANCE

1. Lubrication
This gate has been designed with greaseless bearings. All pivot or turning points have these special bearings. No lubrication is required. If rollers are supplied with great fittings, grease every 90 days using a lithium base grease.
2. Hydraulic
With the platform on the ground, check the oil level. Fill to about 1" from the top of the tank.
3. Electrical
Check for corrosion and/or loose connections.

PREVENTATIVE MAINTENANCE

TLS3500-RLwith Maintenance Minder[®] Solenoid Maintenance by Cycles

CUSTOMER:		
LOCATION:		
VEHICLE#:	LIFT GATE MODEL#:	LIFT GATE SERIAL#:

√ = OK

A = ADJUSTED

N = NOT APPLICABLE

X = WRITE UP REPAIR

2,000	4,000	8,000	MOTOR - PUMP COMPONENTS
			Check that battery hold downs are anchored securely
			Check battery(ies) for proper charge level. PROPER CHARGE LEVEL:
			Check all wiring connections for corrosion and tightness (batteries, switches, etc.)
			Check solenoids for loose fittings and operation
			Check reservoir for correct amount of fluid (platform should be down when checking)
			Inspect and check all circuit breakers. Replace if necessary
			Check the charge line/power line for proper operation and connections at both ends
			Remove and clean all pump solenoid cartridges
			Replace hydraulic fluid in reservoir (see owners manual for recommended fluids)
			Check and adjust the relief valve settings. (See owners manual for recommended setting)
			Check brushes and armature in motor. Replace if necessary
			Check amperage draw of motor (see owners manual for recommended amp draw)
2,000	4,000	8,000	LUBRICATION
			Lightly lubricate platform and ramp hinges
			Lightly lubricate in & out chain with dry lubricant . Not with corrosive lubricants, such as WD40, etc.
			Lubricate rollers, if grease fitting provided
2,000	4,000	8,000	LIFT GATE STRUCTURE INSPECTION
			Operate lift gate in-out. Observe for correct operation
			Raise and lower lift gate. Observe for correct operation
			Check Hoses and Fittings for chaffing, rubbing, and leaks
			If equipped with Emergency Hand Pump check for proper operation (see owners manual)
			Check and adjust in-out chain (should only have 1/2" play)
			Check Automatic Lock for proper operation
			Check track for damage. Repair if necessary
			Check up and down cylinders for leaks. Repack or replace cylinders
			Inspect for broken and/or missing roll pins
			Inspect rollers. Replace if necessary
			Inspect for worn bushings in compression and tension arms. Replace if necessary
			Steam clean gate. Repair any structural welds as needed
			Repaint where needed and replace any worn or missing safety decals

SERVICED BY: _____

DATE: _____

MAINTENANCE MINDER 2 OVERVIEW

Power unit is equipped with the Maintenance Minder 2 Controller. It will:

- Automatically keep track of maintenance intervals, and warn the user when maintenance is due, based on the number of lifts
- Record low voltage occurrences
- Record high temperature faults
- Record maximum run time faults, when a single operation exceeded the maximum continuous run time limit
- Give helpful trouble-shooting information on MENU 4, “Last Lift Info”

FAULT CODES

A decal in the power unit enclosure lists the following signal codes for these faults:

1 BEEP	Service Fault (reached the number of lifts when maintenance is due)
2 BEEPS	Low Voltage Fault (check battery condition and power line connections)
3 BEEPS	Max. Time Fault (exceeded the maximum continuous run time allowed)
4 BEEPS	High Temperature Fault (unit will not run until motor cools)

All fault signals will be repeated **THREE** times. Controller will prevent power unit from operating during the time period when a fault signal is sounding (about 5 to 10 sec.). The controller is also equipped with an anti-doorbelling feature, which prevents rapid ON / OFF operation of the power unit.

RESETTING after MAINTENANCE IS PERFORMED

To RESET the Maintenance Minder 2 after maintenance has been performed:

- 1) Go to MENU 2, hit “Enter”, and toggle down to the “Reset All Info” screen
- 2) Press and hold the hidden RESET button under the Maintenance Minder 2 logo at top of faceplate
- 3) Follow the instructions on the screen regarding a second button, which must be pressed while holding the RESET button to complete the reset operation.

MAINTENANCE MINDER 2 CONTROLLER MENUS

(Press MENU)

MENU 1 – LIFT GATE INFO

(Press ENTER, then ARROW DOWN for each item)

Model Number, Serial Number, Manufacture Date, Vehicle ID,
Hardware Version, Firmware Version, Software Version

(Press MENU and ARROW DOWN once)

MENU 2 – PERIOD INFO (data for the current maintenance period)

(Press ENTER, then ARROW DOWN for each item)

Number of Lifts (gives the number during this maintenance interval / and the set number when maintenance is due)

Motor ON (Total motor run time in minutes for this maintenance period)

Service Faults (number of times gate was operated while PAST the maintenance limit)

High Pressure Faults (not being used, no sensor available)

Max. Time Faults (times motor exceeded its maximum allowable continuous run time)

High Temperature Faults (times thermal switch in motor tripped, if switch provided)

Low Voltage Faults (times low voltage occurred)

Reset all Info (Reset data after performing maintenance, once maintenance limit is reached – instructions will flash on screen after limit reached)

(Press MENU and ARROW DOWN twice)

MENU 3 – LIFE TIME INFO (data for the total life time of the gate)

(Press ENTER, then ARROW DOWN for each item)

Same items will appear as under PERIOD INFO, except this is LIFE TIME data

Reset History (reviews history for each maintenance interval)

Press ENTER, then ARROW DOWN to show history. Most recent period is highest #.
Screen shows Period #, # of Lifts, and Total Run Time in minutes.

Press MENU and ARROW DOWN three times)

MENU 4 – LAST LIFT INFO (Trouble Shooting Screen – it records data that occurred during the last lift made)

(Press ENTER, then ARROW DOWN for each item)

Supply Voltage (first voltage is the minimum voltage that occurred during the last lift – if below 6 volts gate will stop / second voltage is the supply voltage just before gate operation, must be at least 10 volts)

Motor ON Time (motor run time in seconds during last lift, gate will stop at 180 seconds)

Window Time (time in milliseconds during the last lift that the voltage dropped in between 6 and 8 volts – must not be any longer than 3 seconds or gate will stop)

Note: Controller has an anti-doorbelling feature. Motor will not operate if UP switch is toggled rapidly. This prevents start solenoid contact welding.

GENERAL SPECIFICATIONS

CUSTOMER: _____

MODEL: TLS_____

CAPACITY: _____lbs.

TYPE: Trailer Side Door Lift Gate

HYDRAULIC PRESSURE: 2000PSI – Up Function
800PSI – In/Out Function

OPERATION: Power up/Gravity down
Power in/out

SERIAL #:

WARNING:

The use of a battery charger as the sole power source to operate the lift gate is unauthorized and will prevent the lift gate from working properly. The lift gate must always be operated in conjunction with at least one (1) 12 volt heavy duty lift gate battery. A minimum of 9.5 volts must be maintained in order for the valves to operate.

INSTALLATION ADJUSTMENTS

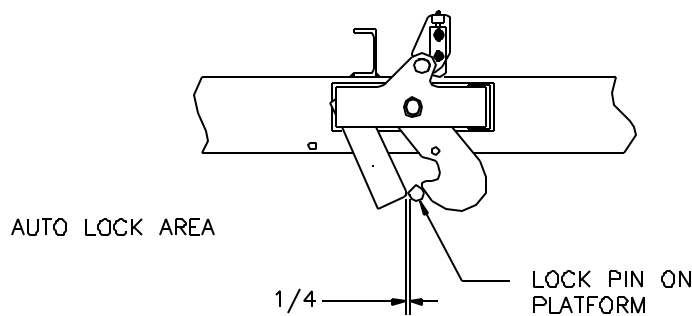
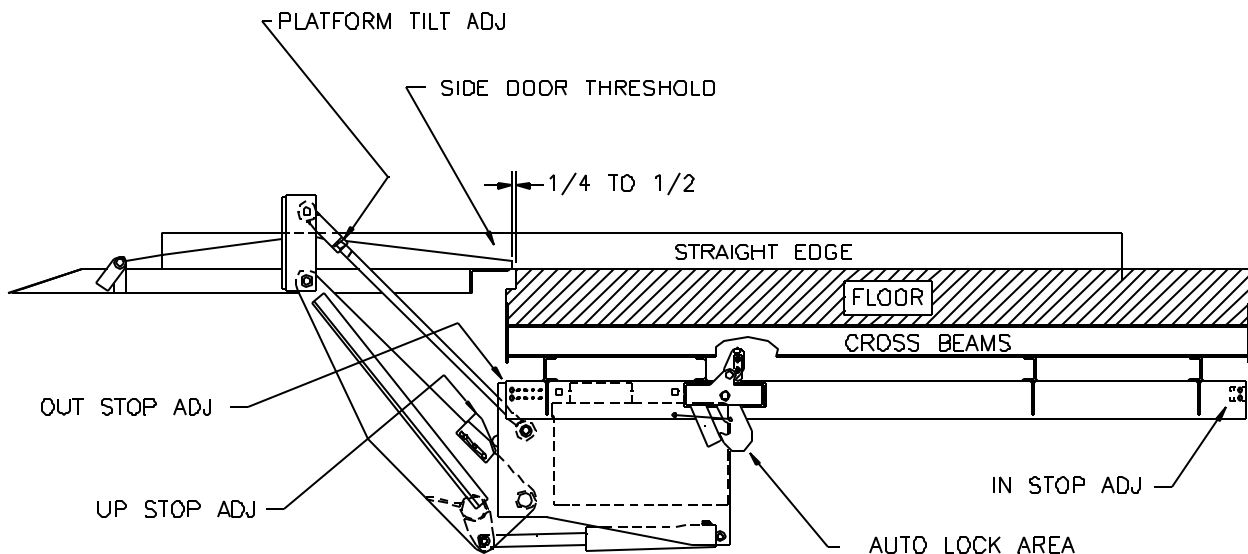

- Step 1: The platform was preset at the factory to be level to the floor of the trailer within $\frac{1}{4}$ ". With a straight edge, check this. If it is okay, proceed to step 2. If not, let the platform down to the ground. Remove the two (2) roll pins and the top tension arm pivot pins (one on each side).
NOTE: One full turn moves the tip of the platform $\frac{1}{4}$ " (turn the end in, this moves the tip off of the platform up, unscrewing moves the tip of the platform down). Make necessary adjustments. Replace pins, raise the platform up and check. Repeat if necessary. Replace roll pins.
NOTE: Each side must be adjusted the same amount.
CAUTION: If this adjustment has been made, the in stop must be adjusted to provide the $\frac{1}{4}$ " clearance with the auto locking pin (see sketch 2).
- Step 2: Adjust the up stops. Platform should be even with the floor of the trailer.
- Step 3: Adjust the out stops. The tip of the platform should be $\frac{1}{4}$ " to $\frac{1}{2}$ " from the edge of the threshold.
- Step 4: Adjust the in stops. See sketch 2 and adjust for the $\frac{1}{4}$ " dimension.

RECOMMENDED HYDRAULIC OILS/LUBRICATION

HYDRAULIC OILS	Manufacturer	Type	Temp. Range
Level 1 Normal Conditions	Mobile	DTE 11	-15° F to + 150° F
	Shell	TELLUS-T15	-15° F to + 150° F
	Exxon	UNIVIS-N15	-15° F to + 150° F
Level 2 Cold Conditions	Mobile	AERO-HFA	-50° F to + 80° F
	Shell	AERO FLUID#4	-50° F to + 80° F
	Exxon	UNIVIS-HVI13	-50° F to + 80° F
	Mil	H-5606	-50° F to + 80° F
HYDRAULIC TANK CAPACITY			
2 ½ gallons			
LUBRICATION		Rollers, if grease fitting provided	Lithium Base Grease
Grease			
BATTERIES			
Two (2) 12 V D.C. Group 31 Deep Cycles			
ELECTRICAL COMPONENTS CONNECTIONS			
Use battery terminal protection Bowman Part#21948			
AMPERAGE DRAW OF MOTOR			
When raising platform (empty) approximately 65 AMPS @ 13.5 volts. At bypass approximately 195 AMPS @ 13.5 volts			
LIFTING PRESSURE SETTING			
With platform at floor level and pump in bypass 2000PSI			
IN-OUT PRESSURE SETTING			
When sliding gate in-out and pump in bypass 800PSI (rollers); 1000PSI (slide pads)			
MINIMUM VEHICLE FLOOR HEIGHT LADEN			
With any size of platform – vehicle floor height 48"			
MAXIMUM VEHICLE FLOOR HEIGHT UNLADEN			
With any size of platform – vehicle floor height 58"			
APPROXIMATE TIMES EMPTY AT 80° F WITH 2 GROUP 31 BATTERIES			
Time up: 14 – 18 seconds Time down(gravity down): 12 –16 seconds			

POWER UNIT REPLACEMENT PARTS

FENNER (GOLD MOTOR) AND SMART START SOLENOID

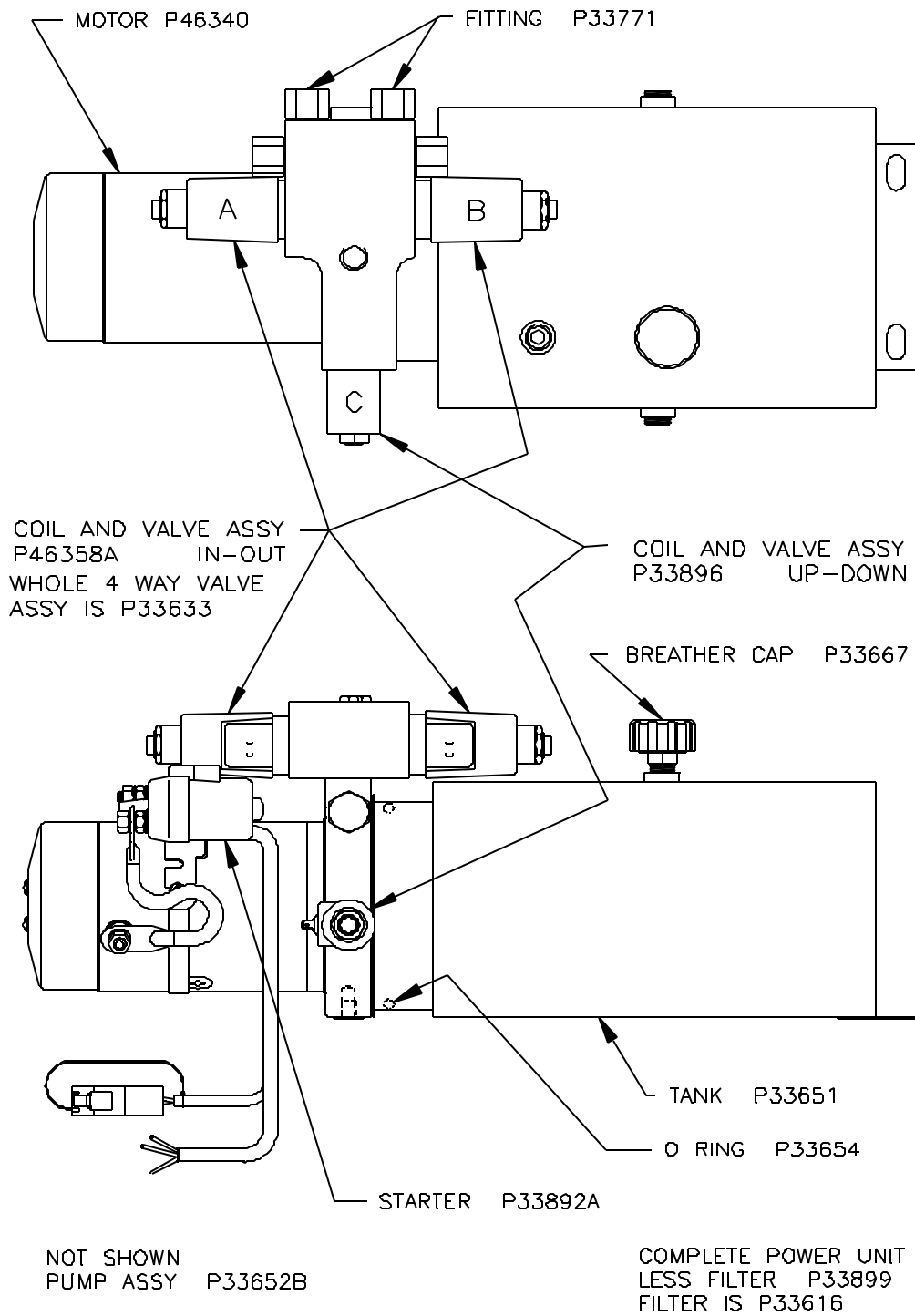

POWER UNIT REPLACEMENT PARTS

FENNER (GOLD MOTOR) AND MAINTENANCE MINDER 2

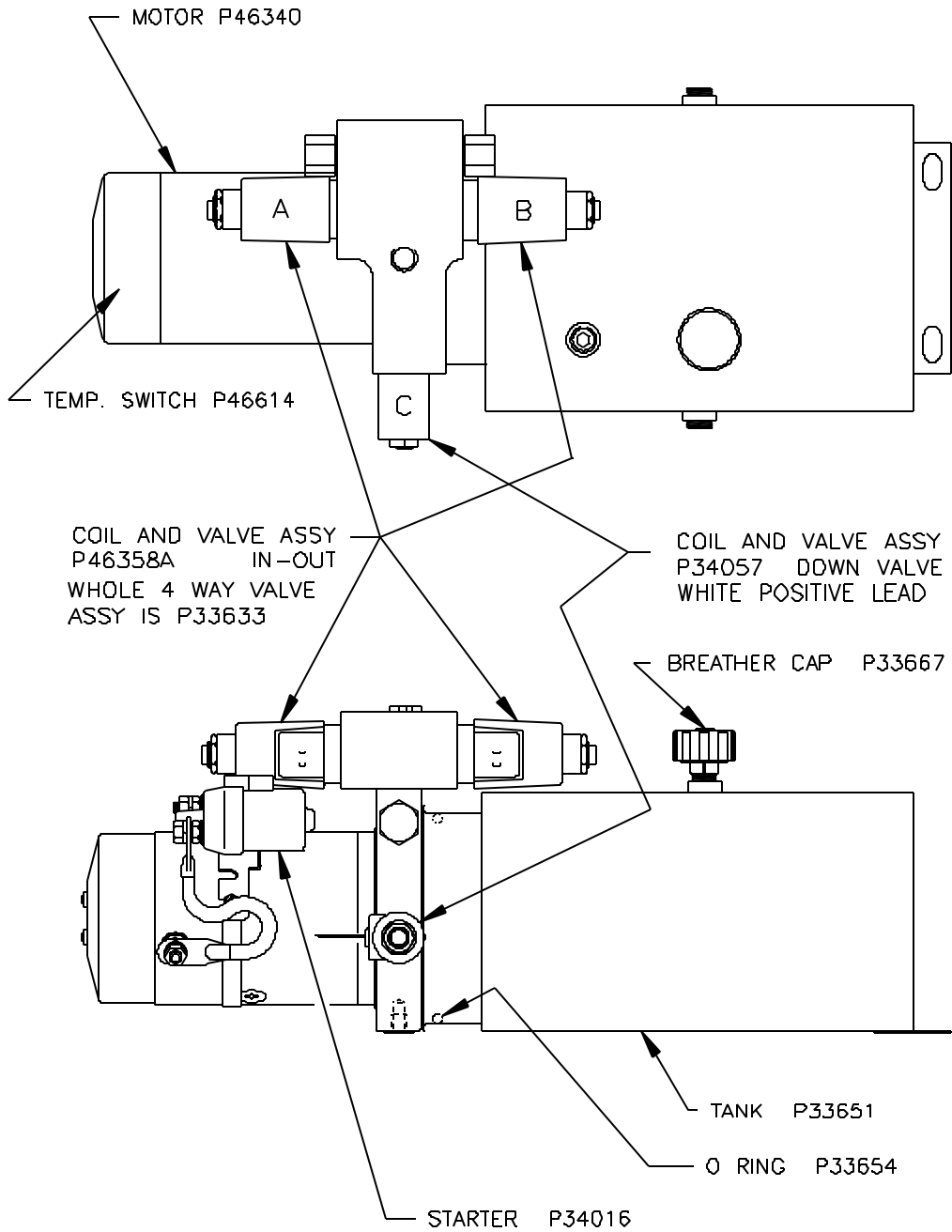

NOT SHOWN
PUMP ASSY P33652B
MAINTENANCE MINDER P46608

COMPLETE POWER UNIT
LESS FILTER P33899
FILTER IS P33616

POWER UNIT REPLACEMENT PARTS

MONARCH (BLACK MOTOR) AND MAINTENANCE MINDER 2

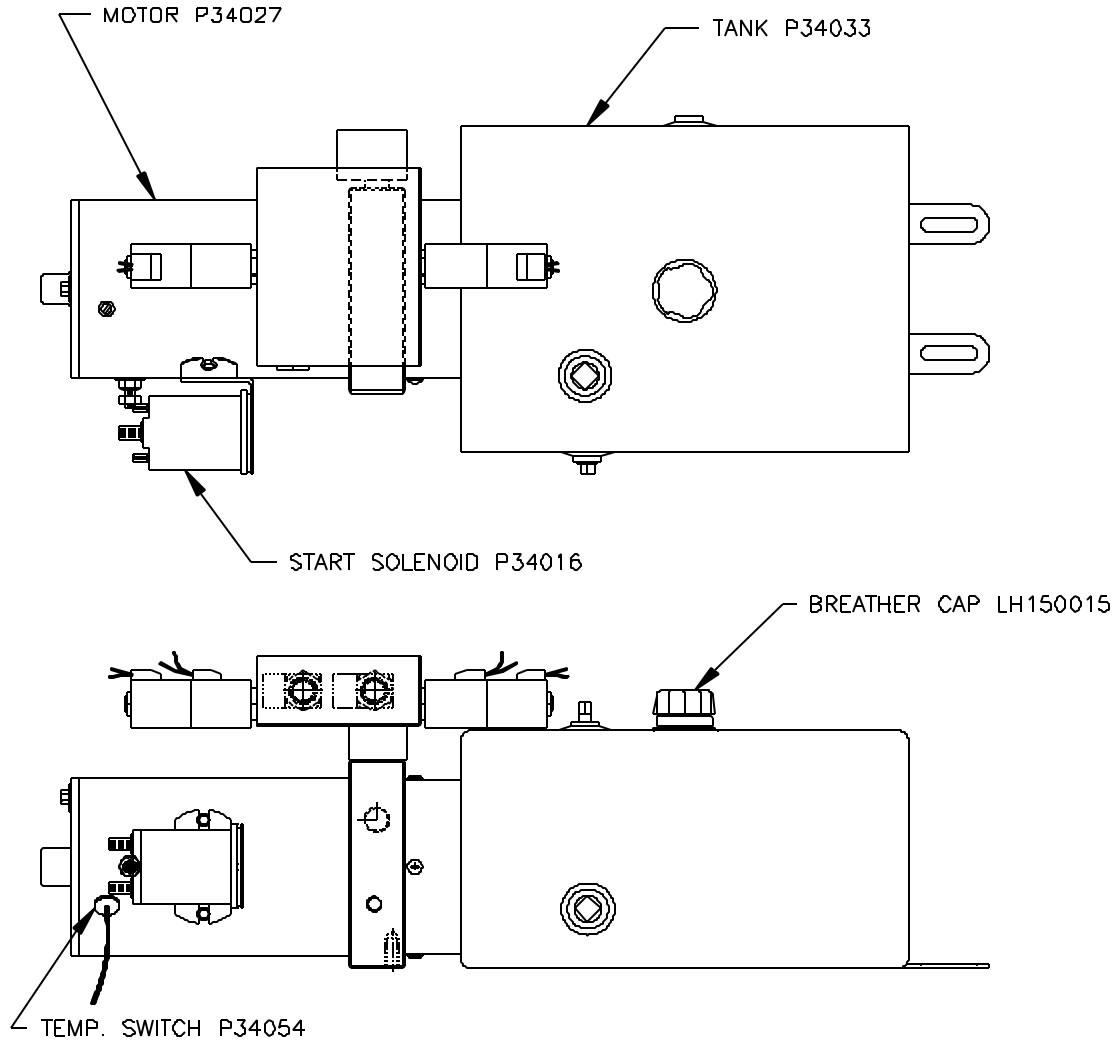

NOT SHOWN
PUMP ASSY P34056
MAINTENANCE MINDER P46608

COMPLETE POWER UNIT
LESS FILTER P34013
FILTER IS P33616

REPLACEMENT BEARINGS AND SHAFTS

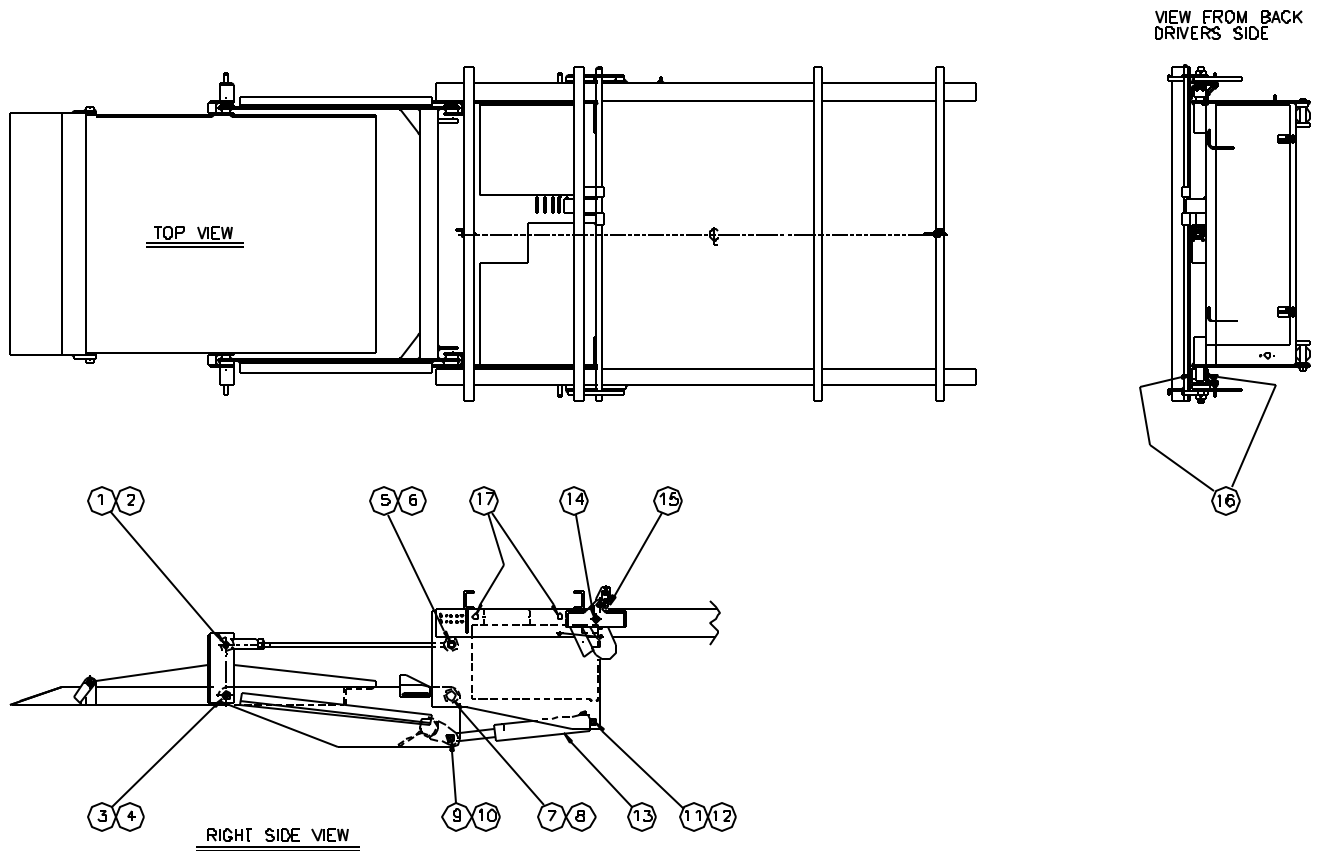

Replacement Bearings and Shafts					
Index #	Req'd	Part #	Part Name	Matl.	Matl. Size
1	2	P43567	Bearing		1 id. x 1-1/2 lg.
2	2	BA-817-085	Pin & Boss	CHR RD	1 dia. x 7-5/8 lg.
3	2	P43567	Bearing		1 id. x 1-1/2 lg.
4	2	AT-999-129-001	Pin & Boss	CHR RD	1 dia. x 3-1/4 lg.
5	2	P43567	Bearing		1 id. x 1-1/2 lg.
6	2	AT-999-129-001	Pin & Boss	CHR RD	1 dia. x 3-1/4 lg.
7	2	P43566	Bearing		1-1/4 id. x 1-1/2 lg.
8	2	AA-817-108	Pin & Boss	CHR RD	1-1/4 dia. x 3-1/4 lg.
9	2	P43574	Bearing		3/4 id. x 1-1/4 lg.
10	2	AT-817-088-001	Pin	CHR RD	3/4 dia. x 3-3/8 lg.
11	2	P43573	Bearing		3/4 id. x 3/4 lg.
12	2	AT-817-088-002	Pin	CHR RD	3/4 dia. x 5-7/16 lg.
13	1	P33944	Hyd. Cylinder		2-1/2 Bore x 12 Stroke
14	2	P43570	Bearing		1 id. x 1/2 lg.
15	2	AP-817-233	Skid Pad		To unlock platform
16	4	P37544	Roller		One Each Corner
17	4	AP-817-044	Side Skid Pad		1 od. x 1-13/16 lg.

CHAIN AREA REPLACEMENT PARTS

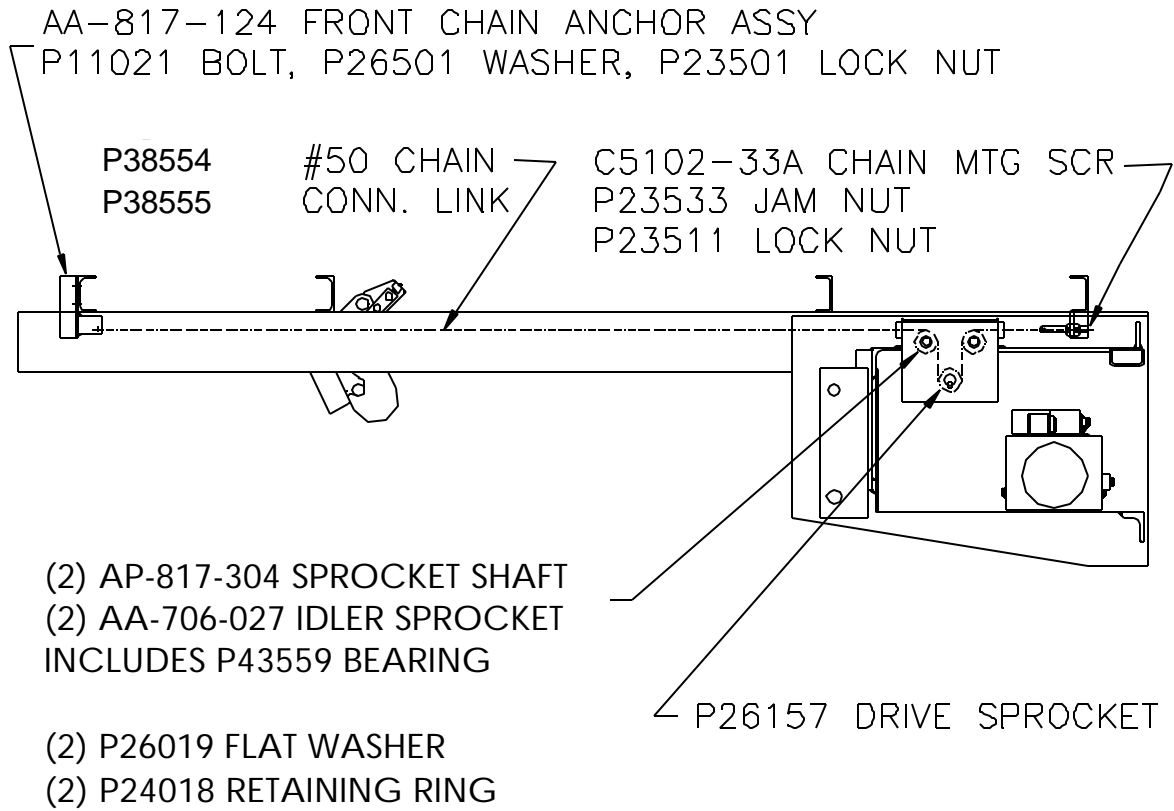

EMERGENCY HAND PUMP

OPTION #107TLS

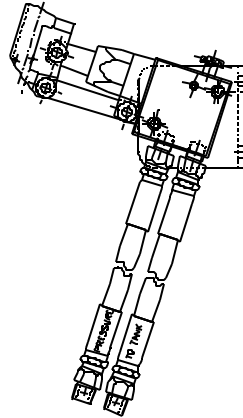
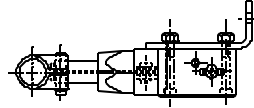

REMOVE TWO PIPE PLUGS
ONE FROM HYD TANK AND
ONE FROM TEE IN FLOOR

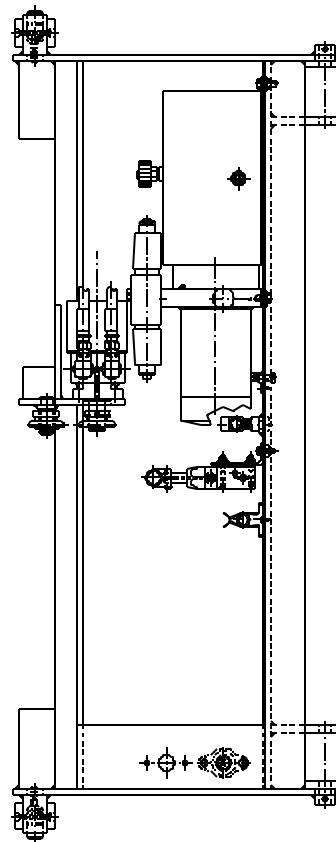
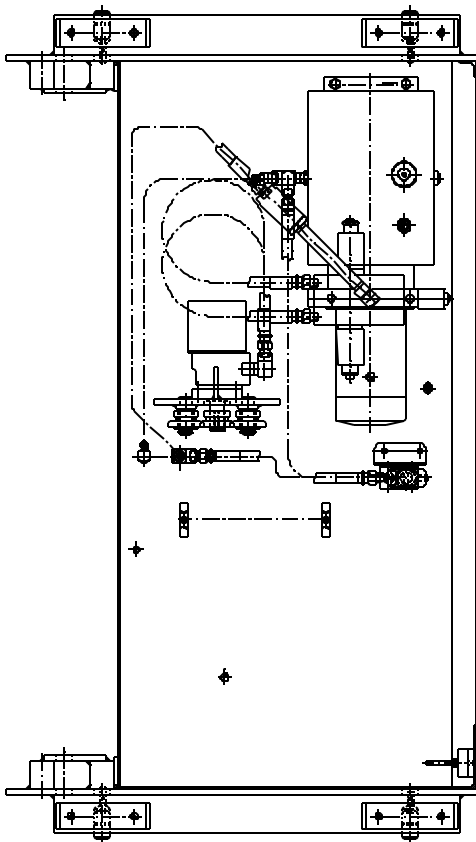

EMERGENCY HAND PUMP

OPTION #107TLS

Hand Pump Opt#107TLS – DA-817-137					
Index #	Req'd	Part #	Part Name	Matl.	Matl. Size
1	1	P33902	Hand pump		
2	1	AP-817-110	Mounting bracket		
3	2	P15541	Soc HD cap screw		¼ - 20 x 2 in. lg.
4	2	P26001	Flat washer		
5	2	P23502	Lock nut		¼ - 20NC
6	2	AT-501-292-020	Hyd line assy		
7	2	P10040	Hex HD screw		5/16 - 18 NC x 1 in. lg.
8	2	P23510	Lock nut		5/16 - 18NC
9	2	P46192	Handle holder		
10	2	P17516	Self tapping screw		10 - 32NF x ½ in. lg.

BRAKE LOCK-UP - OPTION #156TLS

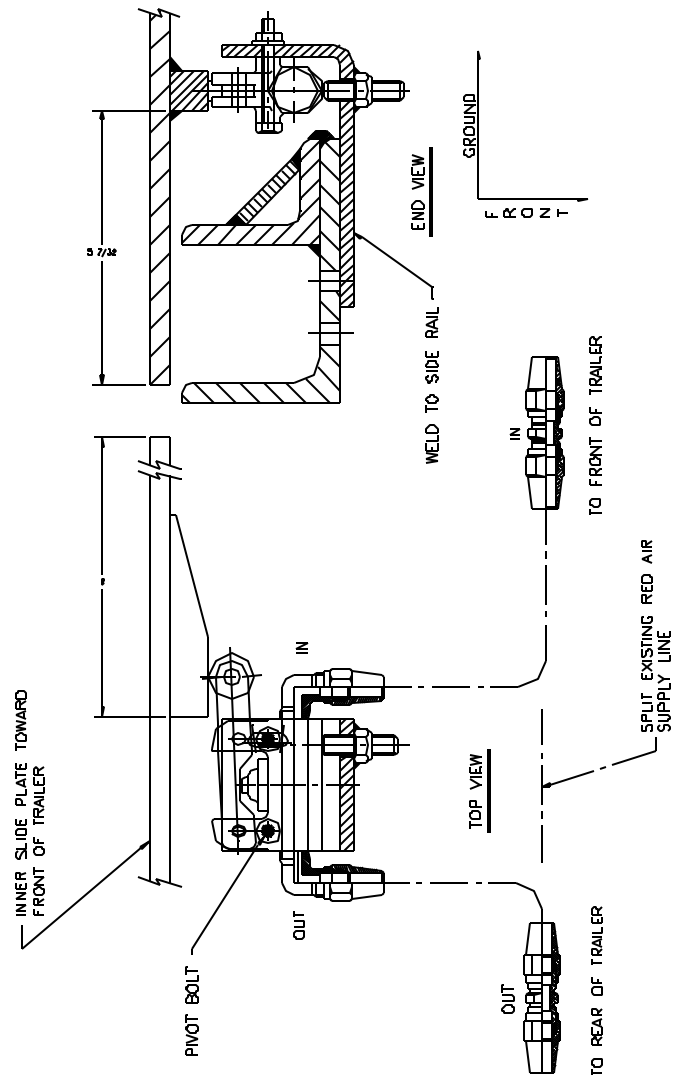

Brake Lock Up Opt#156TLS					
Index #	Req'd	Part #	Part Name	Matl.	Matl. Size
1	1	P33948	3 way valve		With roller
2	2	P33946	90 deg elbow		3/8 00 10-1/4 NPT
3	2	P33945	Female union		3/8 00 tube to 3/8 00 tube
4	1	P33947	3/8 CO red brake tubing		1pc makes two lines-12 ft. lg.
5	1	BA-817-188	Mounting bracket assy		
6	1	BA-817-187	Cam		
7	2	P10557	Hex HD bolt		1/4-20 x 2 in. lg.
8	2	P23007	Plain washer		
9	2	P23502	Lock nut		1/4 - 20
10	1	P14516	Soc HD set screw		3/8-16NC x 1-1/2 lg.

WIRING DIAGRAM (FENNER WITH SMART START SOLENOID)

GOLD MOTOR AND NO TEMPERATURE SWITCH

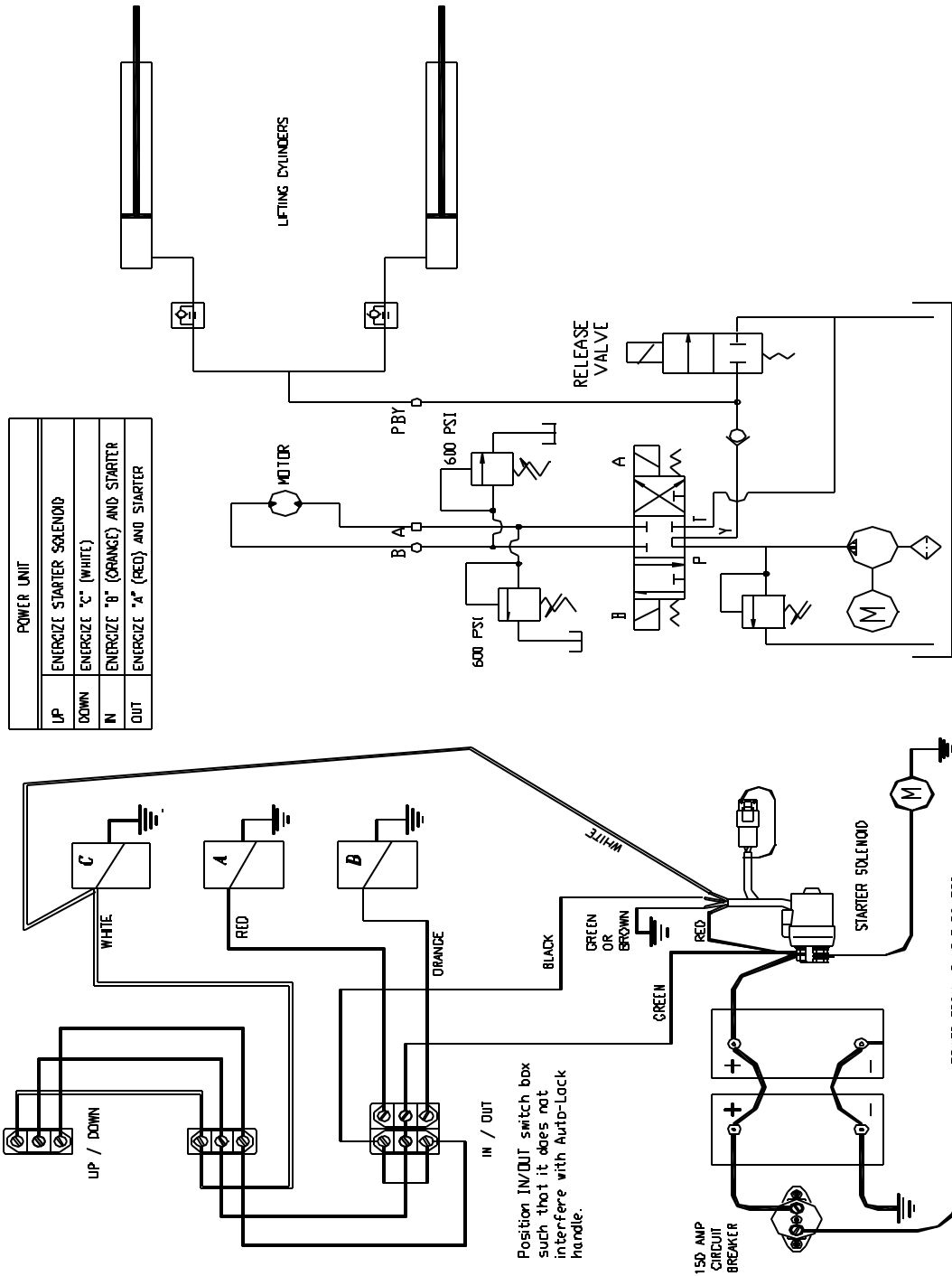

Apply NCCO NCP-2 corrosion protection sealer, or equivalent, at all connectors made during installation.

WIRING DIAGRAM (FENNER WITH MAINTENANCE MINDER 2) GOLD MOTOR AND NO TEMPERATURE SWITCH

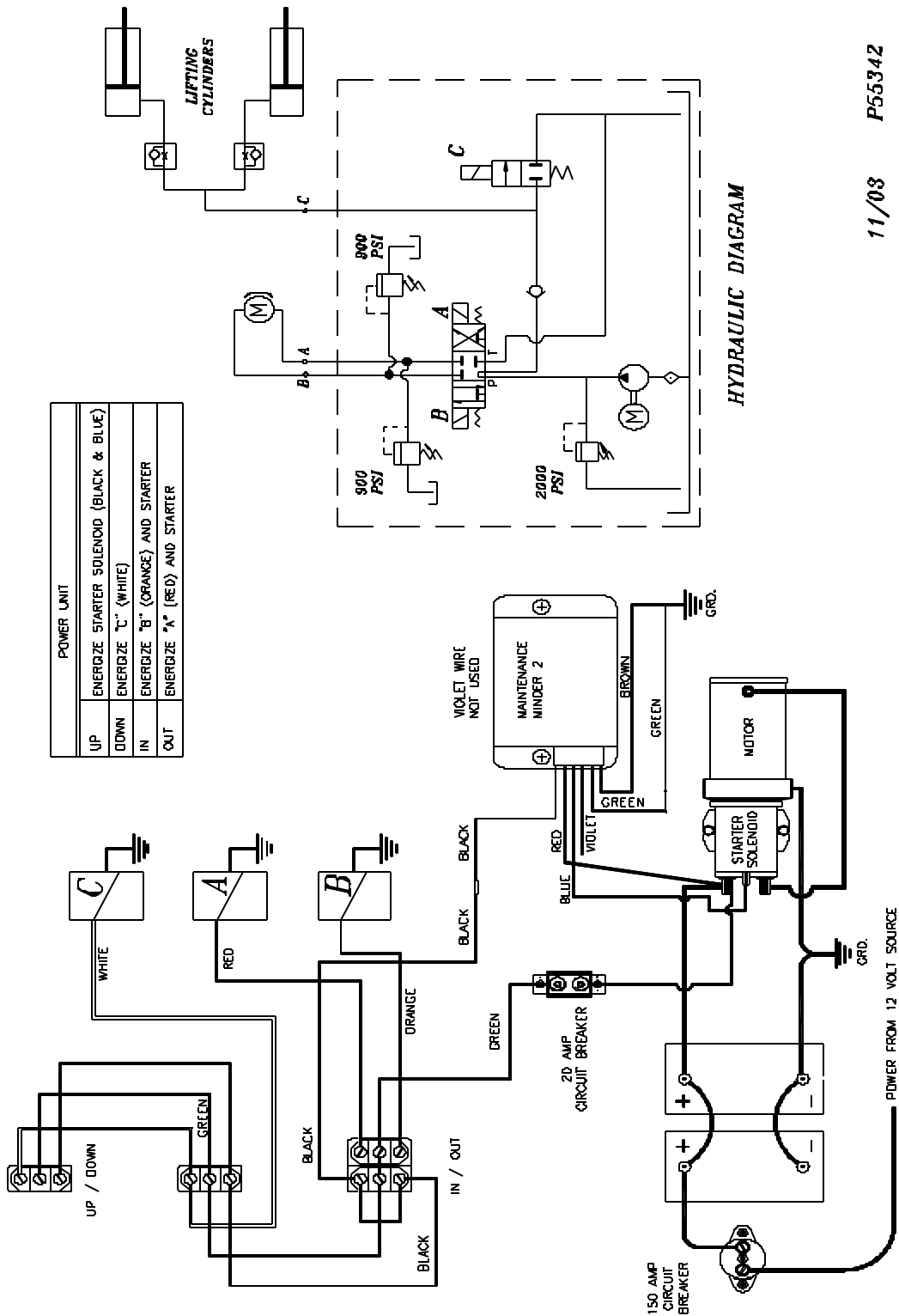

WIRING DIAGRAM (MM2 + TEMP.SW.)

MONARCH (BLACK MOTOR) OR FENNER (GOLD MOTOR)

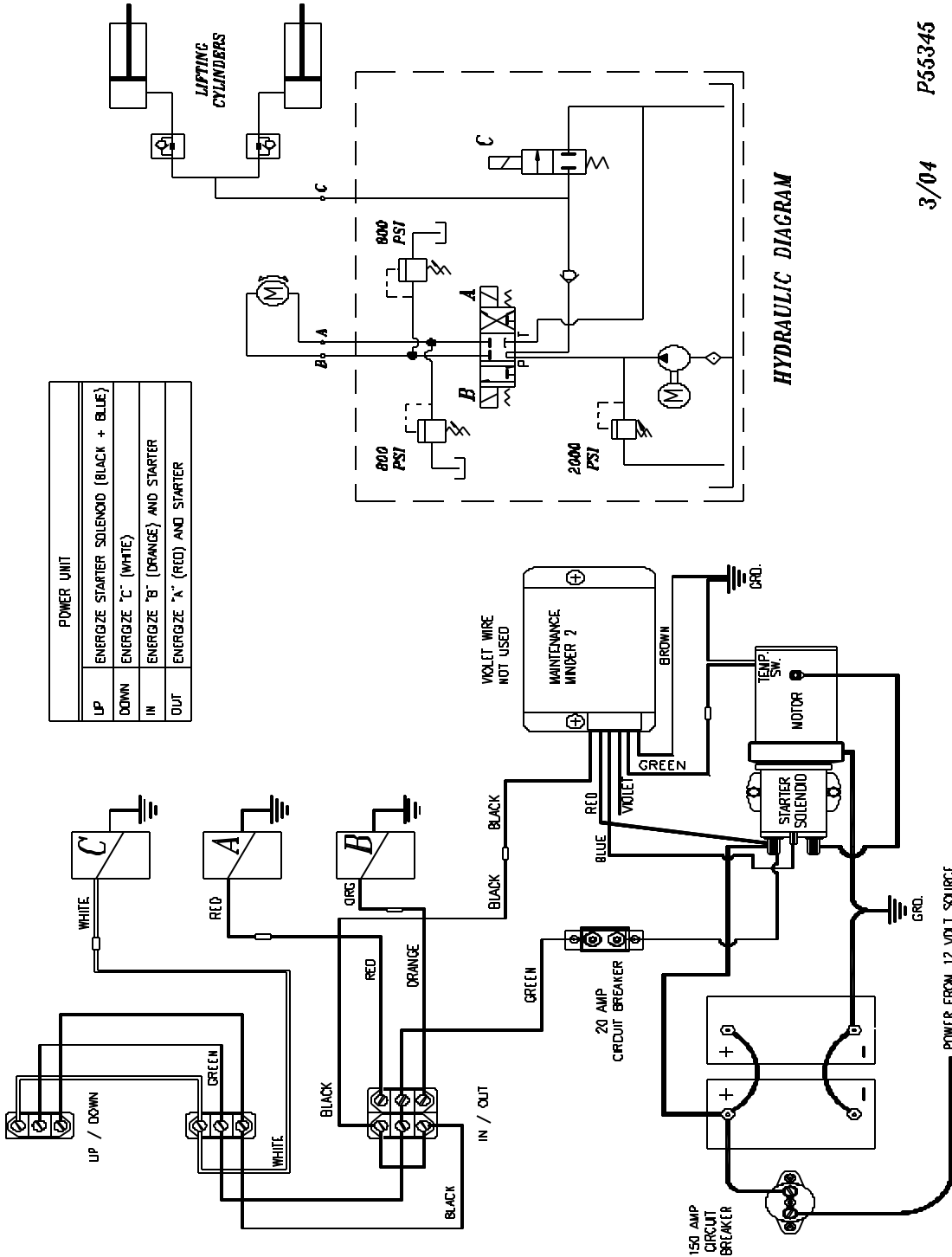

3/04 P55345

BASIC ELECTRICS-WIRING DIAGRAM

After 6-01 FENNER (GOLD MOTOR) AND SMART START SOLENOID

WARNING! REVERSING THE LEADS ON THE "C" DOWN VALVE WILL CAUSE PERMANENT DAMAGE TO THE COIL. LARGE SPADE IS GROUND.

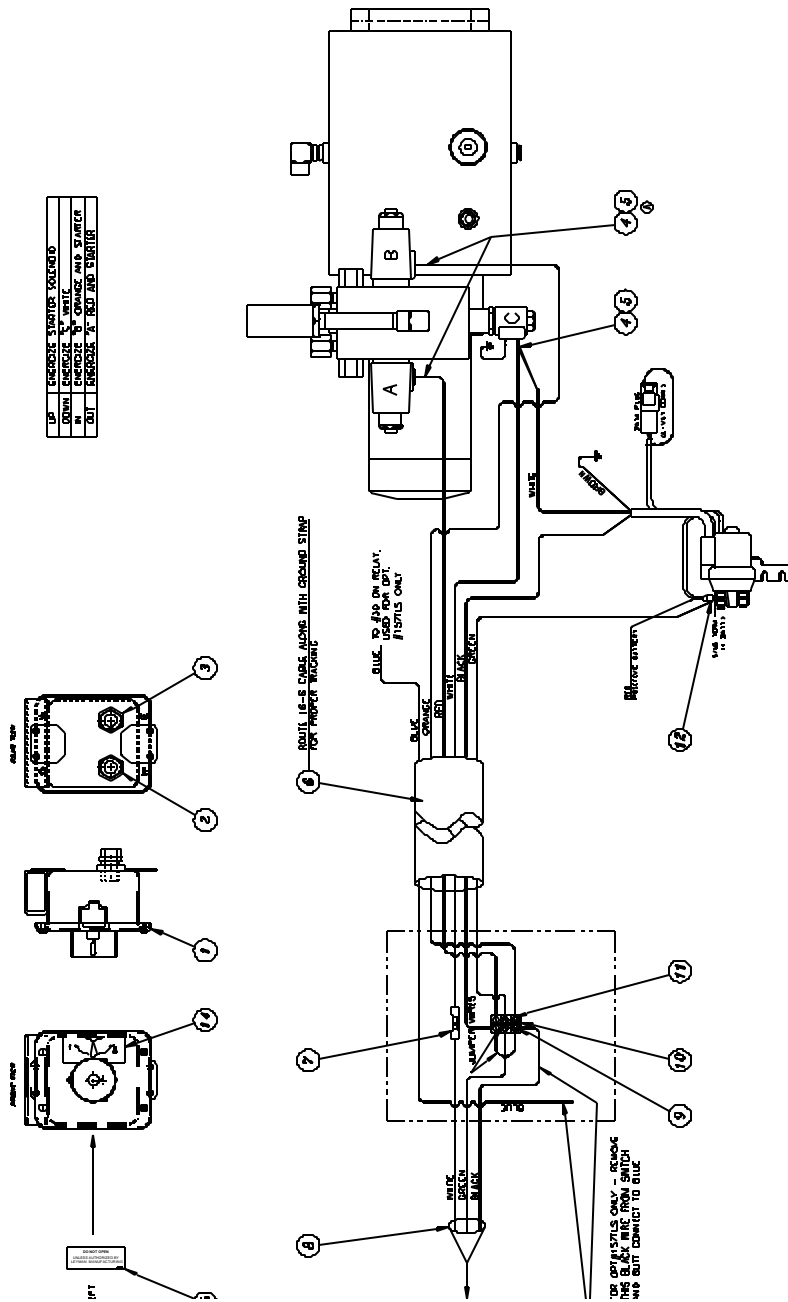

BASIC ELECTRICS-WIRING DIAGRAM

After 6-01

Basic Electrics – CT-551-324						
Index #	Req'd	Part #	Part Name	Matl.	Material Size	Remarks
1	1	BA-551-317	Switch box weldment			
2	1	P46445	Cord grip		For 16-8 cable	
3	1	P46139	Cord grip		For 16-3 cable	
4	6	P46300	Heat shrink tubing		3 pcs. each 2" long	
5	3	P46491	Female connector		3/16	
6	1	P46475	Cable 16-6		See chart for length	
7	1	P46156	Butt connector			
8	1	P46186	Cable 16-3		60" long	
9	4	P46444	Large fork terminal			
10	1	P46442	Toggle switch			
11	2	P46476	Small fork terminal			
12	1	P46235	Large ring terminal			
13	1	P46291	Rubber boot			Not shown
14	1	P55222	In/out decal			
15	1	P55317	Do not open decal			
16	6	P46250	Loom clamp			Not shown
17	6	P17518	Self tapping screw			Not shown
18	1	P55267	Electrics/Hyd. Diagram		Smart start	Not shown
18	1	P55342	Electrics/Hyd. Diagram		MM2, No temp. sw.	Not shown
18	1	P55345	Electrics/Hyd. Diagram		MM2 + temp. sw.	Not shown

BASIC ELECTRICS-WIRING DIAGRAM

Before 6-01

Basic Electrics – CT-551-324						
Index #	Req'd	Part #	Part Name	Matl.	Material Size	Remarks
1	1	P46475	Jacketed wire			
2	1	P46235	Large ring term			
3	3	P46491	3/16 female term		Connect 2 wires together at "C"	
4	6	P46300	Heat shrink tubing		3 pcs. each 2" long	
5	1	P46156	Butt connector			

BASIC ELECTRICS-WIRING DIAGRAM

MONARCH (BLACK MOTOR) AND MAINTENANCE MINDER 2

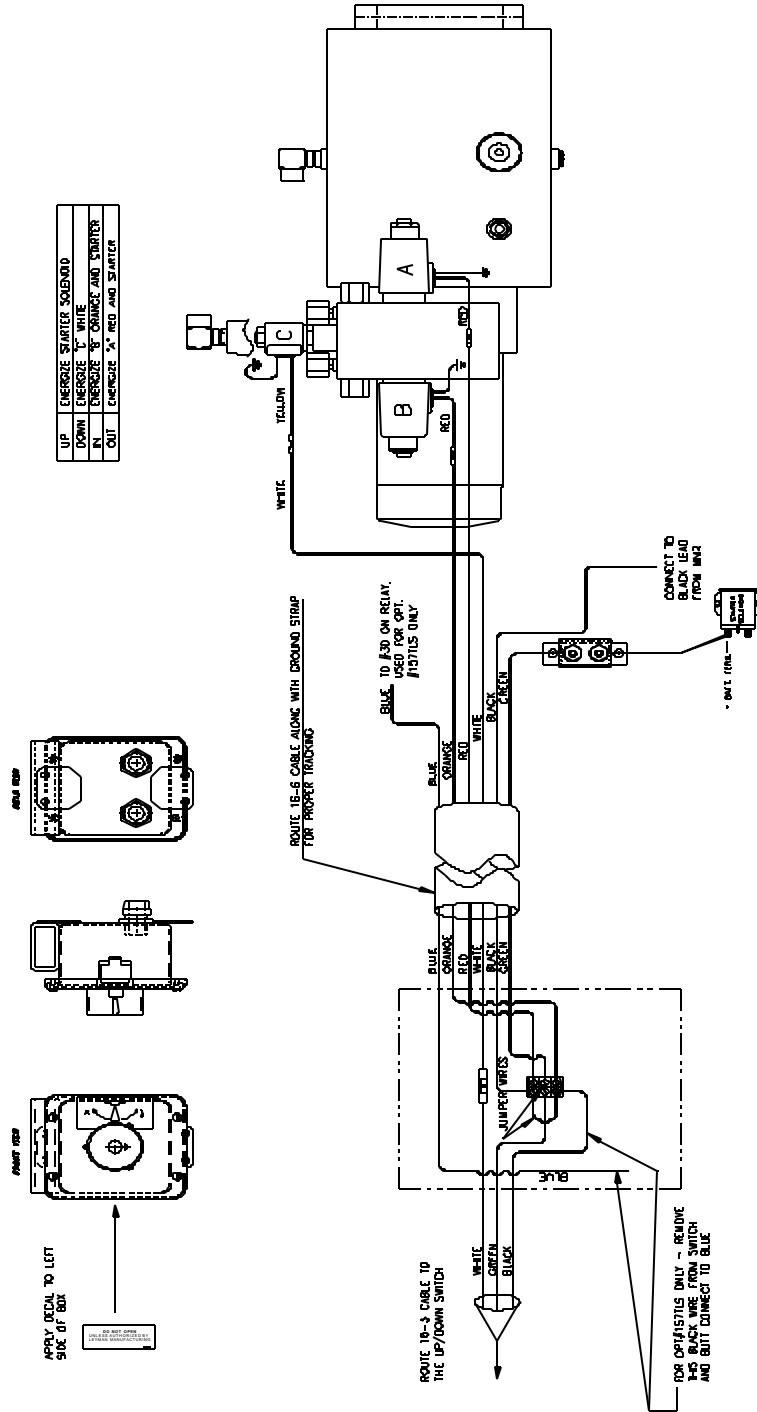

TOGGLE SWITCH ELECTRICS-WIRING DIAGRAM

After 6-01

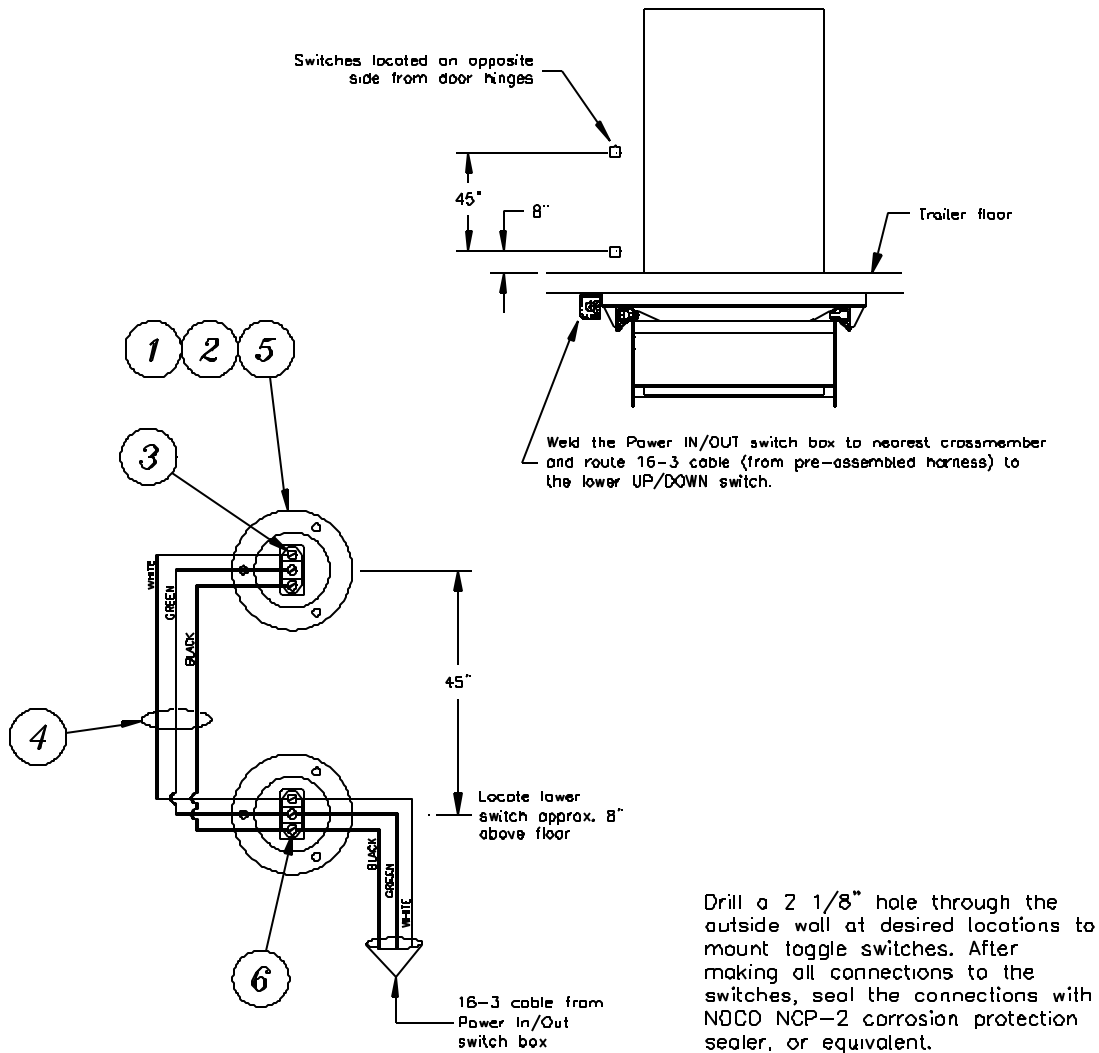

Toggle Switch Electrics – BA-551-323

Index #	Req'd	Part #	Part Name	Matl.	Mat'l Size	Remarks
1	2	P46292	Dish pan			side mtg switch
2	2	P46441	Toggle switch			
3	3	P46476	Fork terminal			
4	1	P46186	Cable 16-3 sow		96 in. (8ft.)	
5	6	P17536	Sheet metal screw		10-16 x 3/4 Type AB	
6	3	P46444	Large fork terminal			
7	4	P46250	Loom clamp			Not shown
8	4	P17518	Self tapping screw			Not shown

TOGGLE SWITCH ELECTRICS-WIRING DIAGRAM

Before 6-01

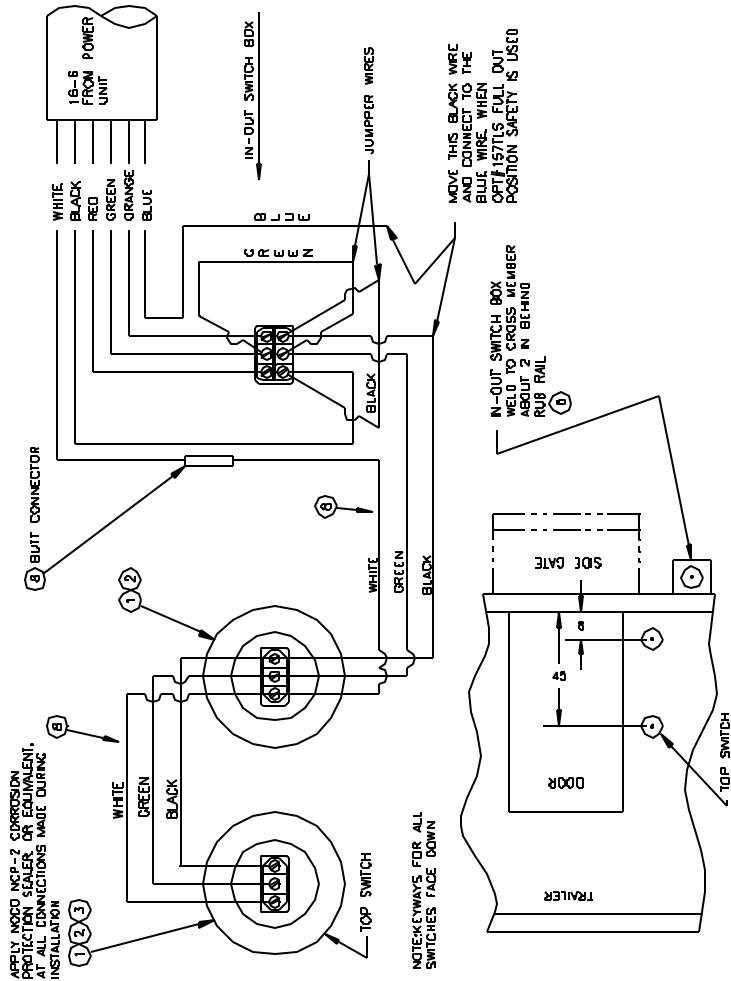

Toggle Switch Electrics – BA-551-323						
Index #	Req'd	Part #	Part Name	Matl.	Mat'l Size	Remarks
1	2	P48292	Dish pan			
2	2	AA-551-326	Toggle switch		Single pole	
3	5	P45476	Fork terminal			
4	1	P46186	Cable 16-3		8 ft. lg. (96 in. lg.)	
5	7	P48444	Large fork terminal			
6	1	BA-551-101	Switch box			
7	1	AA-551-327	Toggle switch		2 pole	
8	1	P46156	Butt connector		2 in. lg.	
9	4	P17518	Self tapping screw		10-32 x ½ lg.	
10	4	P46250	Loom clamp			
11	6	P17536	Sheet metal screw		10-16 x ¾ lg.	

WALK AROUND ELECTRICS - OPTION #103TLS

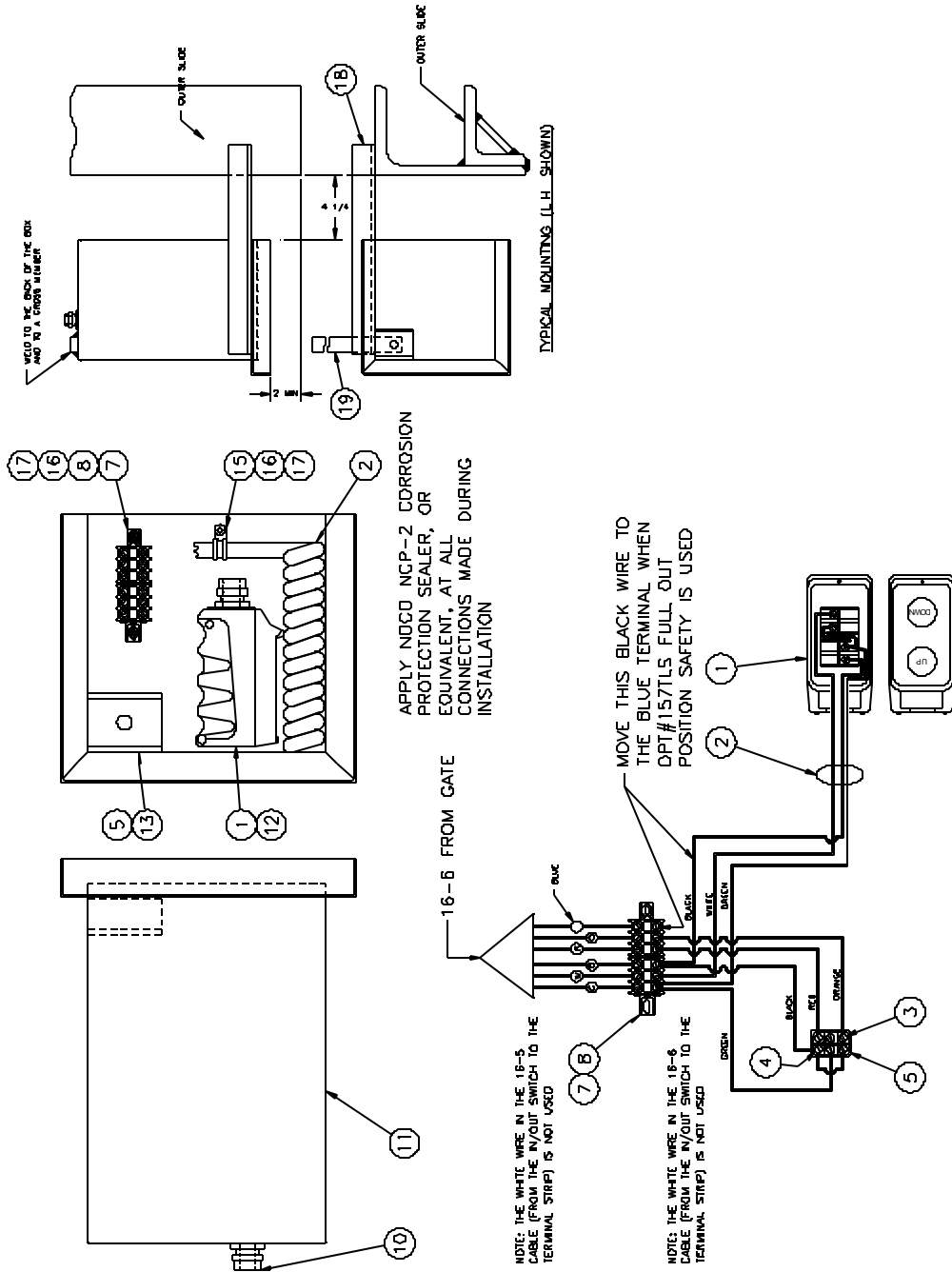

WALK AROUND ELECTRICS –

OPTION #103TLS

Walk Around Electrics – Opt#103TLS						
Index#	Req'd	Part #	Part Name	Matl.	Matl. Size	Remarks
1	1	P46239	Walk around push button			Square D
2	1	AP-551-212	Coil cord (1/2)			
3	4	P46475	Locking fork terminal	Small		
4	2	P46444	Locking fork terminal	Large		
5	1	P46442	Toggle switch			
6	1	P46443	Cable (16-5)		20"	
7	2	P48382	Terminal block	KT3		
8	1	P46395	Terminal block end			
9	1	P56554	Steel plug			In open hole in back of box
10	1	P46445	Cord grip			
11	1	P46138	Push button box			
12	1	AA-999-056	Push button hook assy			
13	1	AP-551-016	Toggle switch bracket			
14	5	P17518	Self tapping screw			Ship loose
15	6	P46250	Loom clamp			Ship 5 loose
16	3	P19501	Round head screw		#10-24 x 1/2	
17	3	P23504	Lock nut		#10-24	
18	1	S580-014.000	Support angle	ST angle	1-1/2x1-1/2x1/4x14	
19	1	S050-006.000	Brace	HR flat	1/4x1/2x6	

ELECTRICAL CONNECTIONS

FULL OUT POSITION SAFETY - OPTION #157TLS

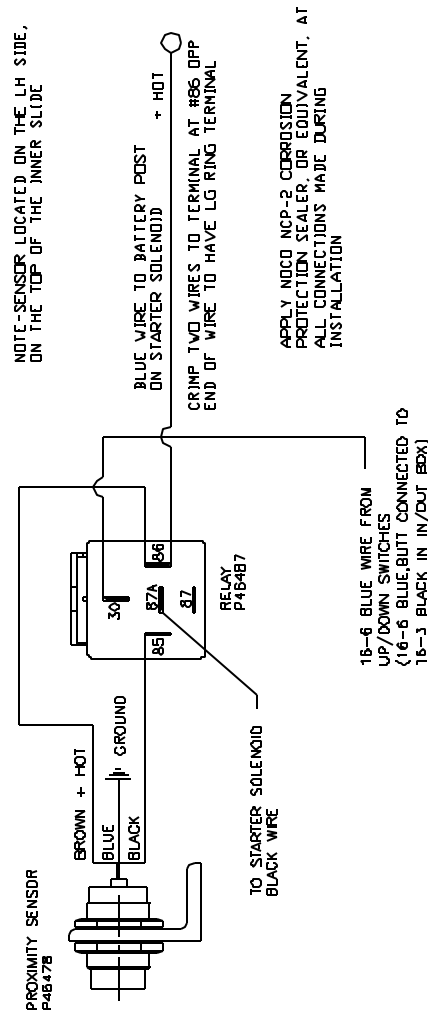

Full Out Position Safety Option#157TLS – CA-551-281

Index #	Req'd	Part #	Part Name	Matl.	Matl. Size	Wgt.
1	1	P46478	Proximity sensor			
2	1	P46487	Relay			
3	1	AP-817-138	Sensor mount		Weld to inner slide cover	
4	1	S566-024.000	Sensor out target	St angle	2 x 1-1/2 x 1/8 x 24	
5	1	S566-003.000	Sensor in target	St angle	2 x 1-1/2 x 1/8 x 3	
6	4	P46318	Female connector		For relay connections	
7	1	P46156	Butt connector		Blk wire on sol to blk wire	
8	1	P17518	Self tapping screw		To mount relay	
9	1	P46235	Large ring terminal			
10	1	P46471	Blue wire – 24" lg.	16 ga.	To provide power to relay	

ELECTRICAL CONNECTIONS

LIGHTS AND SENSORS - OPTION #155TLS

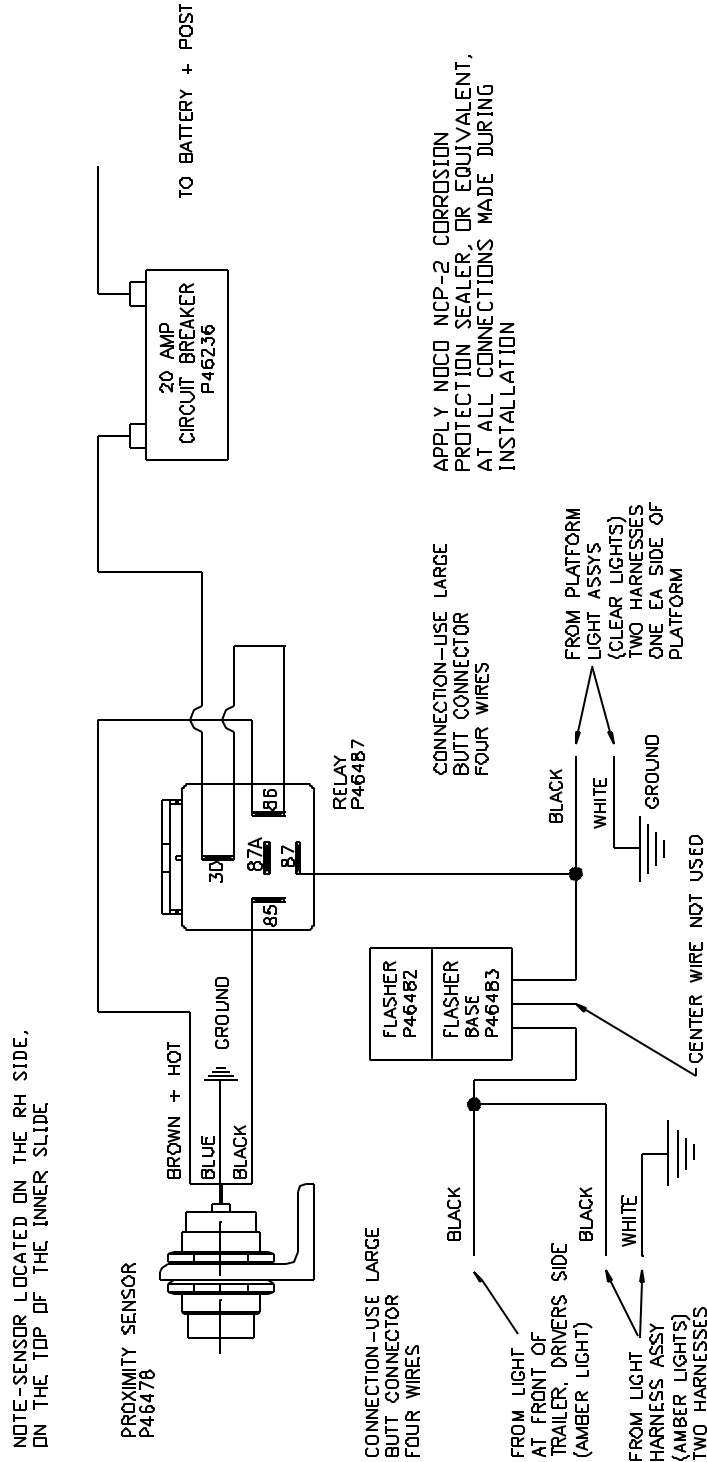

ELECTRICAL CONNECTIONS

LIGHTS AND SENSORS - OPTION #155TLS

Lights and Sensor Electrics Opt#155TLS					
Index #	Req'd	Part #	Part Name	Matl.	Matl. Size
1	1	P46478	Proximity sensor		
2	1	AP-817-138	Sensor mount		Weld to inner slide cover
3	1	S586-003.000	Sensor target	st angle	2 x 1-1/2 x 1/6 x 3
4	1	P46487	Relay		
5	1	P46482	Flasher		Blk wire on sol to blk wire
6	1	P46483	Flasher base		Blk wire on sol to blk wire
7	1	P46236	Circuit breaker		20 amp, auto reset
8	4	P17518	Self tapping screw		CirB-2, relay-1, flasher base-1
9	2	P46235	Large ring terminal		To starter lg hot post
10	4	P46318	Female terminal push dn	16 GA	For relay connections
11	5	P46047	Small ring terminal		To circuit breaker & 3 grounds
12	2	P48531	Lg butt connector		
13	1	BA-551-193	Light harness assy		Includes all lights
14	1	P46017	Black wire 16-GA	50 ft lg	To front of trailer
15	1	P46017	Black wire 16-GA	8 in lg	From clear lights to relay
16	1	P46301	Green wire 16-GA	3 in lg	From relay 30 to relay 86
17	1	P46301	Green wire 16-GA	8 in lg	From relay to circuit breaker
18	1	P46301	Green wire 16-GA	48 in lg	From circuit breaker to battery
19	2	P46017	Black wire 16-GA	15 ft lg	From relay to clear lights

ONE CIRCUIT BREAKER-WIRING DIAGRAM

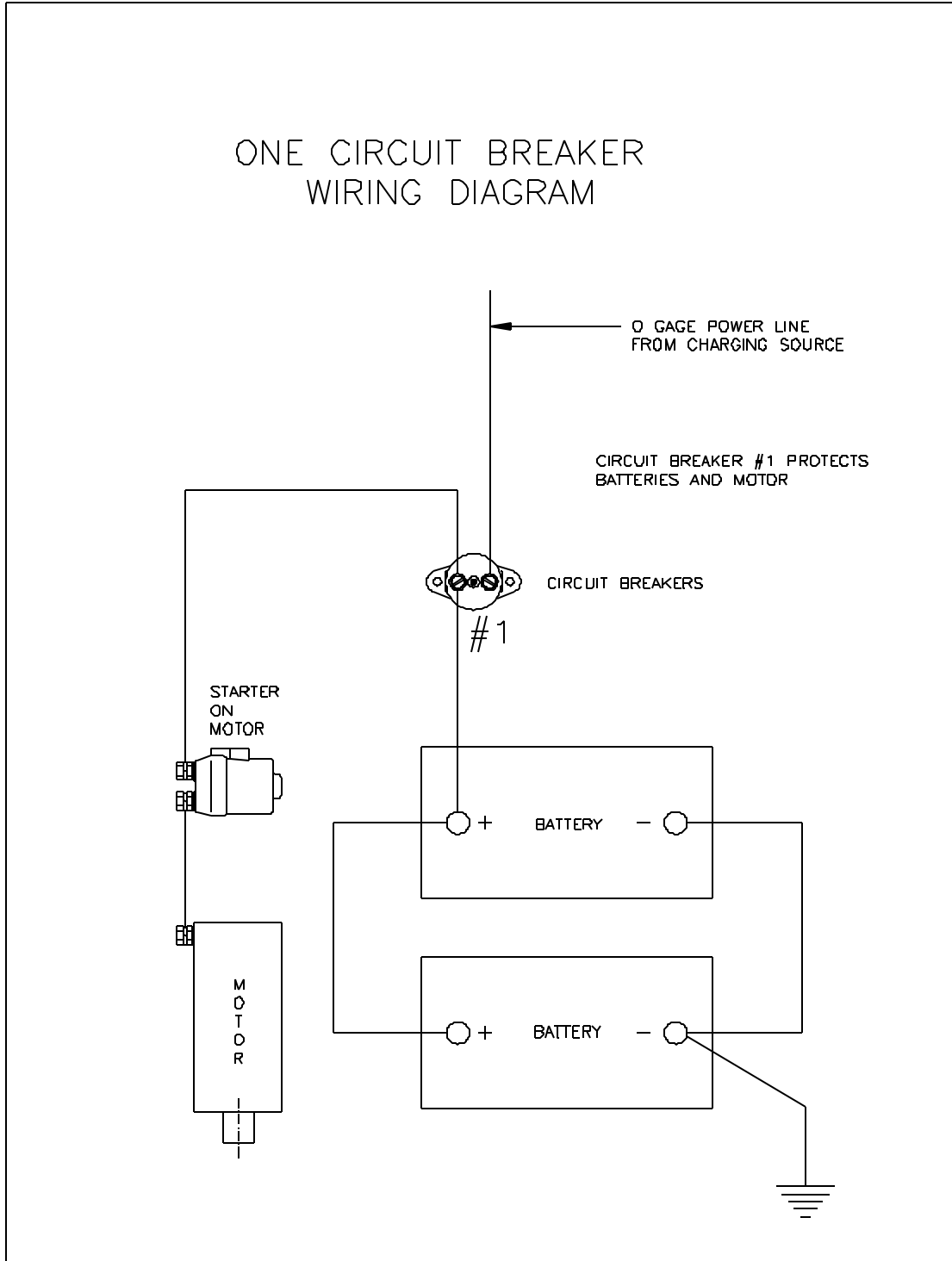

TROUBLESHOOTING CHART

PROBLEM	PROBABLE CAUSE	REMEDY
The motor is running, but the platform will not go up or reach the floor of the vehicle.	<ol style="list-style-type: none"> 1. Low battery. Green light on starter solenoid must be on to run or check MM2 for voltage faults. 2. Insufficient oil in power unit tank. 	<ol style="list-style-type: none"> 1. Recharge or replace battery. 2. Fill tank (55-010-040).
The platform will not go up or reach floor level and the motor does not run.	<ol style="list-style-type: none"> 1. Low battery. Green light on starter solenoid must be on to run or check MM2 for voltage faults. 2. Tripped circuit breaker. 3. Power line is loose. 4. Bad motor, starter or switch 	<ol style="list-style-type: none"> 1. Recharge or replace battery. 2. Reset the circuit breaker. 3. Check the connections. If loose, tighten. Check for corrosion and clean if necessary. 4. To test-push the up switch, if motor does not run, jump the two terminals on the starter solenoid. The motor should run, if not, the motor is bad. If it does run, the solenoid is bad or is not getting a signal from the switch. Use a test light to check (black wire).
Platform will not lower.	<ol style="list-style-type: none"> 1. Low battery. Green light on starter solenoid must be on to run or check MM2 for voltage faults. 2. Bad ground or poor electrical connections. 3. Solenoid valve not opening. 4. Check for obstructions in rails. 	<ol style="list-style-type: none"> 1. Recharge or replace battery. 2. Check connections, if loose-tighten. Check for corrosion and clean if necessary. 3. Lower "C" valve (white wire). Must activate when the switch is pushed. Use test light to check. 4. Visually check.
Platform creeps down.	<ol style="list-style-type: none"> 1. Hydraulic leak. 2. Defective cylinder or piston seal. 3. "C" valve (white wire) not closing. 4. Drain valve on hand pump may be open. 	<ol style="list-style-type: none"> 1. Visually check for leaks. 2. Replace seals or cylinder. 3. Clean and inspect (55-003-003). 4. Check to see if valve on hand pump is closed tightly. Should be tightly closed.
Platform goes down slowly.	<ol style="list-style-type: none"> 1. Check for obstructions or damage to arms. 2. Restricted or pinched hydraulic lines. 3. "C" valve (white wire) not opening. 4. Incorrect hydraulic oil for cold weather operation 	<ol style="list-style-type: none"> 1. Visually check. 2. Check for bent or pinched lines (55-003-004). 3. Clean and inspect (55-003-003). 4. Use Mobile DTE 11 or Aero-HFA for extreme conditions.
Gate will not go out and/or in.	<ol style="list-style-type: none"> 1. Check for obstructions in rails. 2. Low battery. Green light on starter solenoid must be on to run or check MM2 for voltage faults. 3. Tripped circuit breaker. 4. Power line is loose. 5. Bad motor, starter or switch. 6. Insufficient oil in power unit tank. 	<ol style="list-style-type: none"> 1. Visually check. 2. Recharge or replace battery. 3. Reset the circuit breaker. 4. Check the connections. If loose, tighten. Check for corrosion and clean if necessary. 5. To test: push out switch and motor does not run, jump the two terminals on the starter solenoid. The motor should run, if it does not run, you have a bad motor. If it does run, the solenoid is bad or it is not getting a signal from the switch. Use test light to check (out is "A" valve "red wire", in is "B" valve "orange wire").

