



wPrime™ Series 280W-R

RESIDENTIAL ULTRASONIC WATER METER

Applications

- Revenue metering
- Residential submetering
- Commercial buildings
- Leakage detection
- AMR / AMI and billing
- Drive-by metering



Features

- Residential potable water consumption metering
- Temperature compensation for cold water as well as hot water up to 60°C (140°F)
- No moving parts. Wear-free ultrasonic technology
- Durable, proven BRASS sensor body. Solves the challenges in harsh environments
- Patented sensor design. provides precise signal, robust performance, and is not impacted by water impurity
- Excellent long-term stability with consistent performance. Accuracy does not degrade over time
- Maintenance-free
- Leakage detection
- Tamper-proof design. Records when tampering is detected
- Not affected by magnetic interference
- Does not measure entrained air in pipe
- Bi-directional flow
- Low pressure drop
- Free positioning for installation
- Large LCD, 9 digits display
- More than 10 year battery life
- IP 68 water-proof
- Better than OIML R49 / ISO 4064 Class D
- OMS-complaint wMBus radio module for drive-by meter reading or AMR/AMI fixed meter reading
- Data Logger with 700 daily totals and 24 monthly totals
- Optional SpireCapture AMR/AMI and Billing solutions

DS-280WR-1410_Rev 14



Spire Metering Technology LLC, 249 Cedar Hill Street, Marlborough, MA 01752, USA

Tel +1 978 263-7100 / 888 738-0188 (toll-free) **Fax** +1 978 418-9170 sales@spiremt.com www.SpireMT.com



wPrime™ Series 280W-R

RESIDENTIAL ULTRASONIC WATER METER

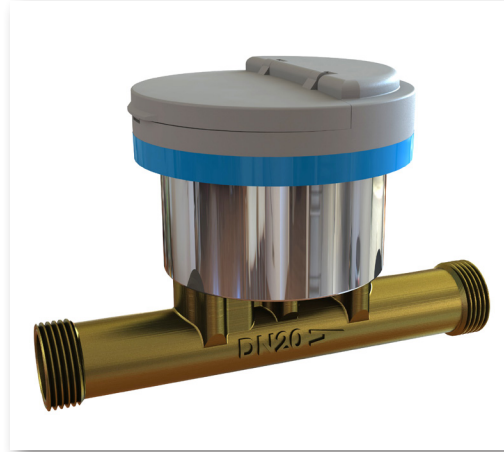

A member of the wPrime™ Series, the 280W-R Residential Ultrasonic Water Meter is specially designed for domestic water metering applications where conventional water meters fail due to harsh environment, solids in water, performance degradation, magnetic vandalization or are incapable of leakage detection.

The 280W-R offers the most advanced water flow measurement by using state-of-the-art ultrasonic technology. Its flow sensor does not have any moving parts that can wear or tear, which provides a robust and accurate meter with no maintenance required.

The technical specifications of the 280W-R meet the standards for residential utility metering with Class D performance, operational temperature from 0.1°C to 60°C and safety temperature up to 85°C, as well as nominal pressure of 1.6MPa. The wide dynamic range allows for a load up to double the rating, thereby ensuring high operation security. The large LCD can display the flow total, leakage alarm, reverse flow, and more. The meter also has a remote readout which could be configured as M-Bus, Encoder or RF wireless.

Spire Metering's 280W-R Residential Ultrasonic Water Meter stands out among its competition due to its robust performance, patented sensor design, tamper-proof feature, multiple AMR / AMI options and capability to detect very low flowrates. It works reliably even when the water has particles and the environment is harsh, such as the case in Middle East and Africa. Residential installations can profit from the advantage of the wear-free water flow measurement, namely, precision, operation security and long service life.





wPrime™ Series 280W-R

RESIDENTIAL ULTRASONIC WATER METER

Operating Principle

The wPrime™ series water meter consists of a flow sensor and an integrator. The flow sensor is a flow-cell made from brass (figure below.) Two ultrasonic transducers, A and B, are firmly mounted on the flow-cell at optimal positions, with two reflectors inside of the flow tube. The ultrasonic signal generated by one transducer is directed toward the flow direction by the reflector below it. When the ultrasonic signal reaches the other reflector, it is redirected to the transducer above it. Therefore, each transducer can receive the signal sent from the other transducer.

An integrator (or calculator) controls the two ultrasonic transducers to transmit and receive ultrasound in an orderly fashion to conduct precise flow measurement. Specifically, the integrator operates the two transducers to simultaneously transmit a pulse of ultrasonic energy into the water flow. The pulse signal travels along the flow and reaches the other transducer under the guidance of the two reflectors. Obviously, the downstream pulse (from A to B) travels faster than the upstream pulse (from B to A). The travel time (or transit-time) difference of the two pulses is directly proportional to flow velocity. Therefore, the flow rate can be derived from the transit-time difference accordingly.

The wPrime™ series water meter has used advanced digital signal processing technology to precisely measure the transit-time of each ultrasonic pulse. A statistic algorithm is also used to counter interference which could come from solids or air bubbles in the water. The flow-cell is optimally designed according to our patented technology, so that the multimode reflection in the flow tube is significantly attenuated. It allows a significant increase in signal strength and quality, thus, the robustness of the system. The flow rate calculation is based not only on transit-time difference and the geometry of the flow-cell, but also on fluid dynamics theory.

Only ultrasonic pulses are used to interrogate the flow which enables the meter to have no moving parts. Therefore, there is nothing to wear out or cause a reduction in accuracy. In addition, the principle is based on the transit-time difference instead of transit-time, all the interfering factors, such as the temperature, pressure, solids concentration and water quality, are cancelled out. The end result is that the system is inherently robust!

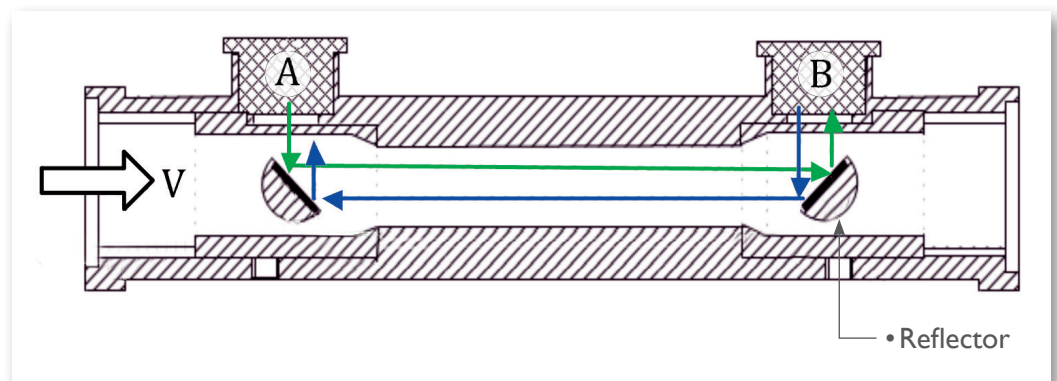



wPrime™ Series 280W-R

RESIDENTIAL ULTRASONIC WATER METER

Automatic Meter Reading

The wPrime™ series water meter offers a variety of interface options, such as M-Bus, RS485 with Modbus, as well as built-in OMS-compliant WMBus. It is flexible to be integrated into an AMR/AMI system or a drive-by system.

Spire Metering also offers a complete range of AMR/AMI solutions as well as an integrated billing system. The SpireCapture system is a cutting edge fixed automatic meter reading system which integrates both wired and wireless AMR/AMI technologies. The system provides a unified platform for meter reading and data management through M-Bus networks, RF wireless networks, GSM networks, GPRS networks, BACnet networks as well as TCP/IP networks. In addition, it works seamlessly with Spire Metering's billing software to make data exchange easy, fast and reliable.

SpireCapture is an advanced, highly robust meter reading solution that delivers comprehensive

usage information as well as timely, high-resolution meter reading. This data enables gas, water, heat and electric utilities to eliminate on-site visits and estimated reads, reduce theft and loss, implement time-of-use billing, and profit from all of the financial and operational benefits of a fixed-network AMI/AMR.

In addition to an automatic meter reading, Spire Metering also offers a drive-by solution. For detailed information on drive-by system and AMR/AMI system, please contact us at solutions@spiremt.com.

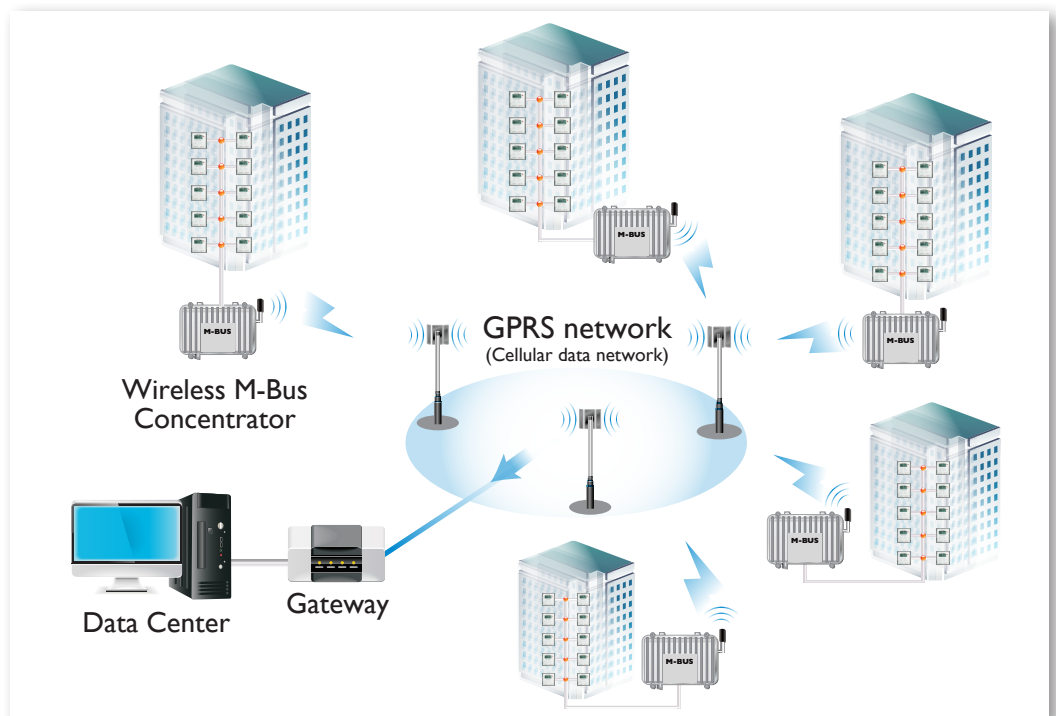



wPrime™ Series 280W-R

RESIDENTIAL ULTRASONIC WATER METER

Technical Specifications

Size		Flowrate						Dimensions						Pressure Loss (bar)	Weight (kg)	Pipe Joint (BSP)	
mm	in	Q ₃		Q ₄	Q ₂	Q ₁	Q ₅	L		L1	H	H1	Φ			Sensor	Ext. Piece
		m ³ /h	GPM	m ³ /h	l/h	l/h	l/h	mm	in	mm	mm	mm	mm				
15	½	2.5	11.0	3.125	16	10	3	165	6½	261	102	167	108	0.48	0.8	G3/4B	R1/2
20	¾	4	17.6	5	25.6	16	4	195	7.68	301	107	172	108	0.27	0.95	G1B	R3/4
25	1	6.3	27.74	7.875	40.32	25.2	5	225	8.86	347	112	177	108	0.23	1.2	G1 1/4B	R1
32	1¼	10	44.03	12.5	64	40	6	260	10¼	386	121	186	108	0.38	1.4	G1 1/2B	R1 1/4
40	1½	16	70.45	20	102.4	60	8	245	9.65	366	132	197	108	0.42	1.6	G2B	R1 1/2

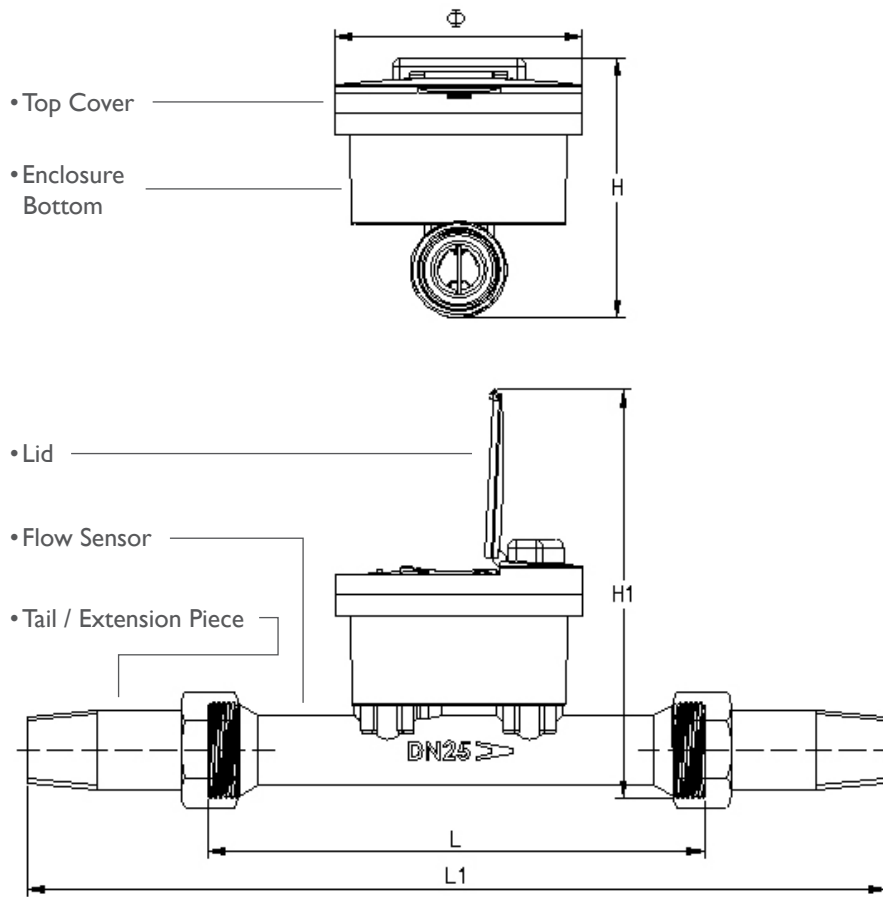

Notes:

- Default pipe joint is BSP threading.
- NPT threading is available upon request.
- L is flow sensor length. L1 is the total length of flow sensor plus extension pieces.
- Weight does not include extension piece. Weight may vary, please contact us for exact weight.
- 1m³/h is about 4.4GPM.
- Dimension H, Φ1 and Φ2 are for reference only. Please contact us for exact measure.
- Optional strainer



wPrime™ Series 280W-R

RESIDENTIAL ULTRASONIC WATER METER

Approvals

OIML R49, ISO 4064, NSF61, MID

Electrical Data

Power Supply:	Battery, 3.6V, Lithium
Replacement Interval:	>10 years at $t_{BAT} < 30^{\circ}C$ (86°F)
Power Consumption:	<0.1W
Backup Power Supply:	Internal SuperCap
Communication Interface:	M-Bus (default). Optional: RF 433MHz or RF 868MHz wMBus*, RF 470MHz long range, Encoder or Modbus
CE approval:	EN61326-1:2006
Electromagnetic Class:	E2

Accuracy / MPE (Maximum Permissible Error)

MPE according to ISO 4064: 2005 or OIML R49
± 2 in the range $Q_2 \leq Q < Q_4$; ± 5 in the range $Q_1 \leq Q \leq Q_2$ [for $T \leq 30^{\circ}C$ (85°F)]
± 3 in the range $Q_2 \leq Q < Q_4$; ± 5 in the range $Q_1 \leq Q \leq Q_2$ [for $T > 30^{\circ}C$ (85°F)]
Dynamic Range: 250 (For others please contact SpireMT)

***Note:** for OMS-compliant wMBus, please contact support@spiremt.com for details.

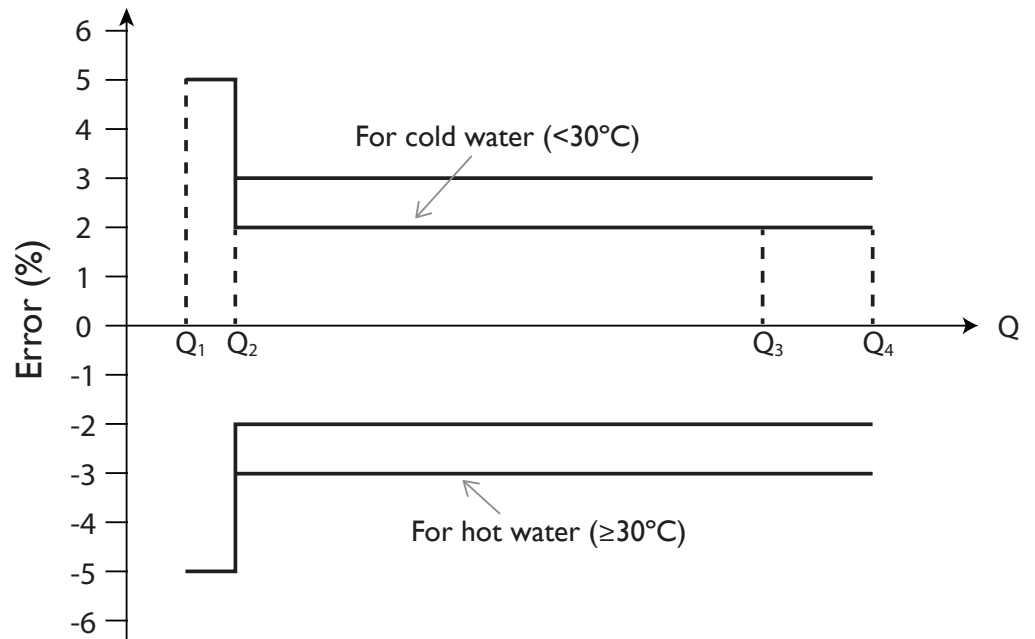



wPrime™ Series 280W-R

RESIDENTIAL ULTRASONIC WATER METER

Mechanical Data

Metrological Class: 2 (according to ISO 4064: 2005 or OIML R49)
Environmental Class: B / C
Environmental Temp: 0 ~ 60°C (32 ~ 140°F)
Permissible Flow Temp: 0.1 ~ 60°C (35 ~ 140°F) for long term and up to 85°C (185°F) for short term.
Enclosure Protection: IP68
Integrator Detachable: No
Pressure: PN16

Pressure Loss

The pressure loss of a flow sensor is proportional to the square of the flow: $\Delta p = k \times Q^2$
Here Δp is pressure loss, Q is volume flow rate and k is the coefficient.
The DN15 (1/2") meter has $k=0.067$ and Δp less than 0.48bar at Q_3 .
The DN20 (3/4") meter has $k=0.019$ and Δp less than 0.27bar at Q_3 .
The DN25 (1") meter has $k=0.006$ and Δp less than 0.23bar at Q_3 .
The pressure loss for all sizes meet the ISO 4064: 2005, OIML R49 and AWWA standards.

Pressure Loss vs. Flowrate

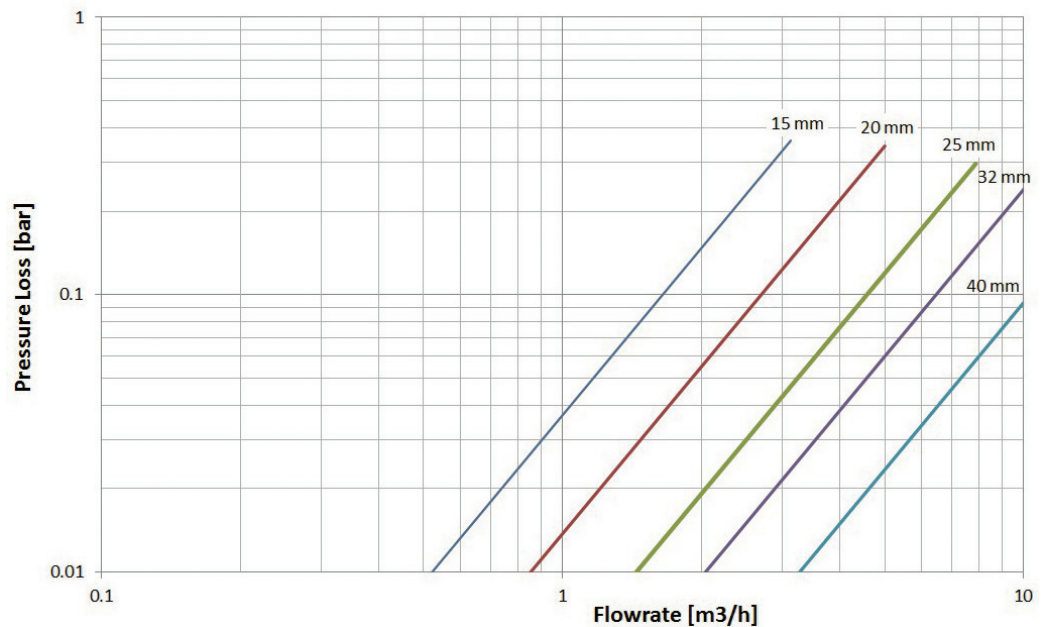



wPrime™ Series 280W-R

RESIDENTIAL ULTRASONIC WATER METER

Order Specifications

Attention



You must also order one output interface module from the Required Components table to make a complete system.

Base Unit

280W-R-DN - - - **B**

Meter Size

DN15 / 1/2"	15
DN20 / 3/4"	20
DN25 / 1"	25
DN32 / 1 1/4"	32
DN40 / 1 1/2"	40

Accessory

0	None
1	With tail piece and non-return valve(default)

Pipe Joint

A	BSP (default)
B	NPT

Required Components (Choose One)

Output Interface Module	Model No.
M-Bus Module (wired)	280WA-MB
RS485 / Modbus Module	280WA-485MOD
RS485 Module (for 485-BACnet/ MSTP Adapter only)	280WA-485
Encoder Module for Metric Unit	280WA-E-DNxx
Encoder Module for English Unit	280WA-E-INxx
433MHz RF with Battery (wMBus-OMS)	280WA-RF433-B
470MHz RF Module with Battery (long range)	280WA-RF470-B
868MHz RF Module with Battery (wMBus-OMS)	280WA-RF868-B

Optional Components

External Adapter	Model No.
485-BACnet / MSTP Adapter (RS485 Module is required)	280WA-BACTP485

Example

- **280W-R-DN20-A-2-B** stands for the 280W-R wPrime™ Series Residential Water Meter base unit of R250 for pipe DN20mm BSP pipe joint and a pair of tail pieces with non-return valve.
- **280WA-MB** stands for an M-Bus module for the 280W-R water meter.

About Spire Metering Technology

Spire Metering is a global leader in flow and energy management solutions.

Through continuous innovation, we transform complex ultrasonic technology into affordable, reliable solutions for accurate flow and energy measurement. Spire Metering offers water, heat, electricity and gas meters as well as AMR/AMI solutions. To find out how we can help today, please tell us about your application.

