

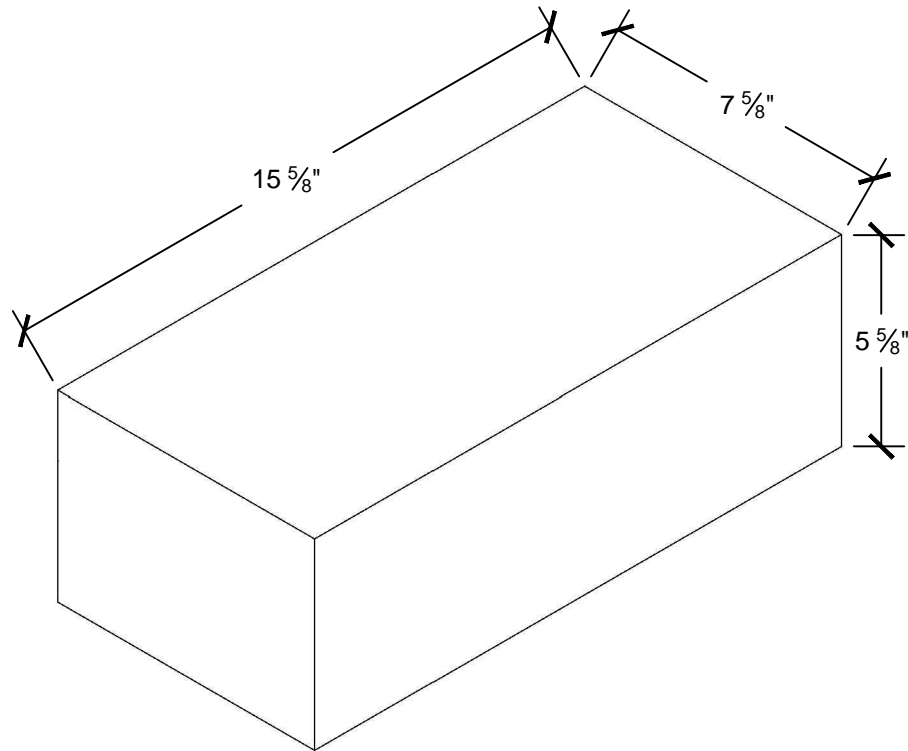

	05/06/16	XXX		REV_DESC		MF	WHR	JML	
REV	DATE	DES		REVISION DESCRIPTION		CADD	CHK	RVW	

6"x8"x16" Ballast Block



NOTES:

- **WEIGHT:**
-55 lbs/ea.
- **COMPRESSIVE STRENGTH, MIN P.S.I. (AVG. GROSS AREA)**
-AVG. OF 3 UNITS: 4500
-INDIVIDUAL UNITS: 4500
- **WATER ABSORPTION MAX (LB/FT³)**
-AVG OF 3 UNITS: 10%
- DRY CAST BLOCK WITH $\frac{3}{8}$ " AGGREGATE
- NO DIMENSION SHALL VARY MORE THAN 3 PERCENT OVER OR UNDER THE SPECIFIED DIMENSION FOR ANY FORM OF UNIT
- ASTM C-139-05 EXCEPT THAT THE UNITS SHALL CONFORM TO THE DETAILS SHOWN HEREON AND THAT THEIR THICKNESS SHALL NOT BE LESS THAN 5"

			
PROJECT			
TITLE			
6x8x16 BALLAST BLOCK			
DESIGN	BGR	05/06/16	FILE No.
CADD	MF	05/06/16	SCALE 3"=1'-0"
REVIEW	MW	05/06/16	REV.
PROJECT No.			
DRAWING: 6x8x16 BALLAST			