

△	11/18/13	XXX	REV_DESC	LJH	WHR	JML
REV	DATE	DES	REVISION DESCRIPTION	CADD	CHK	RW

24" YARD DRAIN

PAINTED OR GALVANIZED GRATES
CONFORMS TO ASTM C913

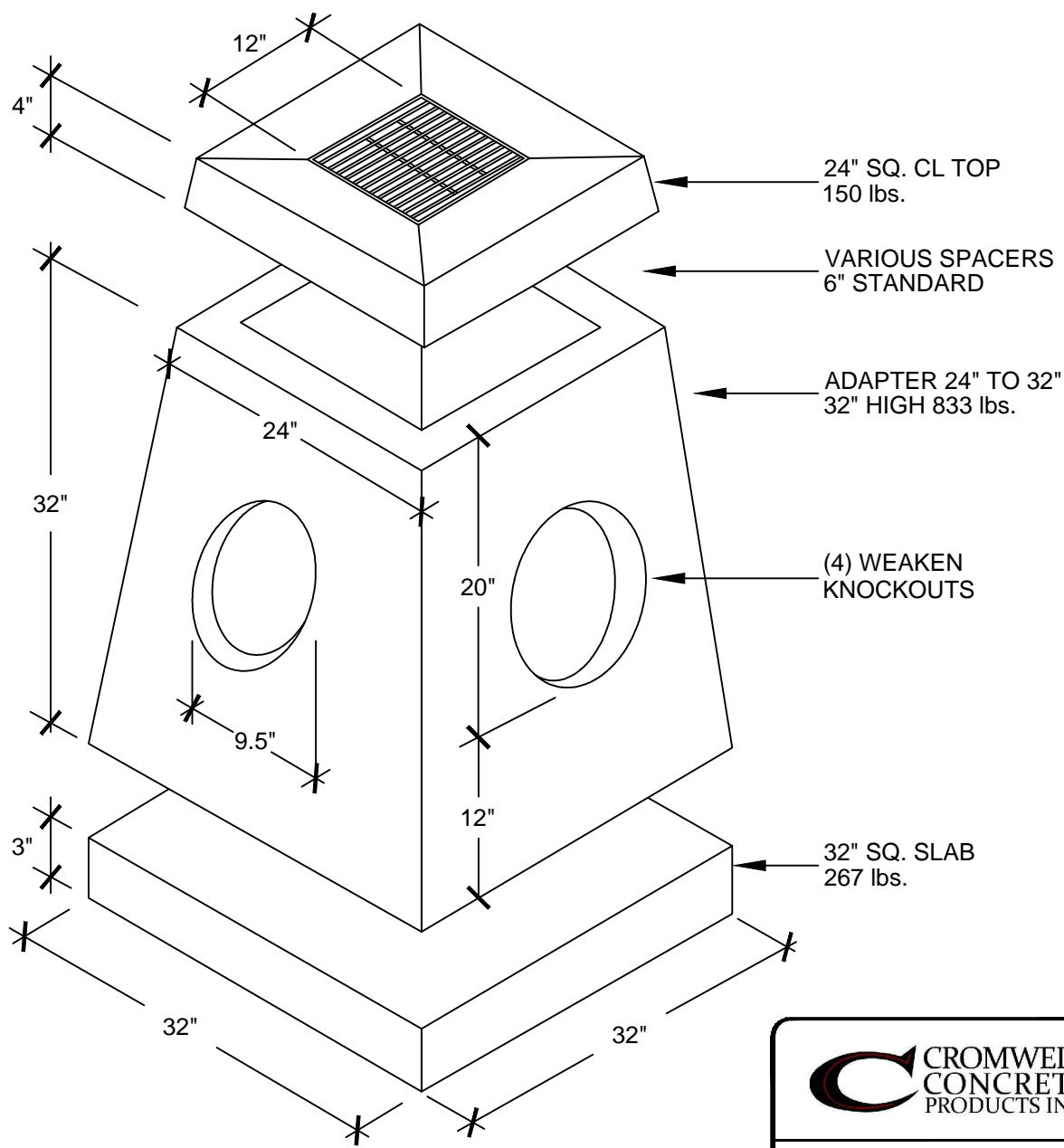

- 24" SQ. CL TOP
150 lbs.
- VARIOUS SPACERS
6" STANDARD
- ADAPTER 24" TO 32"
32" HIGH 833 lbs.
- (4) WEAKEN
KNOCKOUTS
- 32" SQ. SLAB
267 lbs.

**CLASS "FSC" SELF-CONSOLIDATING CONCRETE
4,000 PSI**



**CROMWELL
CONCRETE
PRODUCTS INC.**

PROJECT

TITLE

24" YARD DRAIN

DESIGN	BGR	01/29/14	FILE No.
CADD	LJH	01/29/14	SCALE AS SHOWN
REVIEW	MF	12/08/15	REV. 0

PROJECT No.

DRAWING: 24-YARD DRAIN