

|     |          |     |                      |      |     |     |
|-----|----------|-----|----------------------|------|-----|-----|
| △   | 12/22/15 | XXX | REV_DESC             | MF   | WHR | JML |
| REV | DATE     | DES | REVISION DESCRIPTION | CADD | CHK | RW  |

**TYPE II SUMP**  
 CURBED OR CURBLESS  
 CONFORMS TO ASTM C913

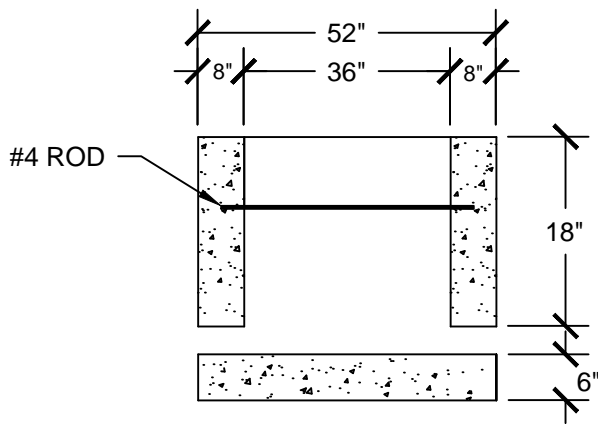

SECTION A-A

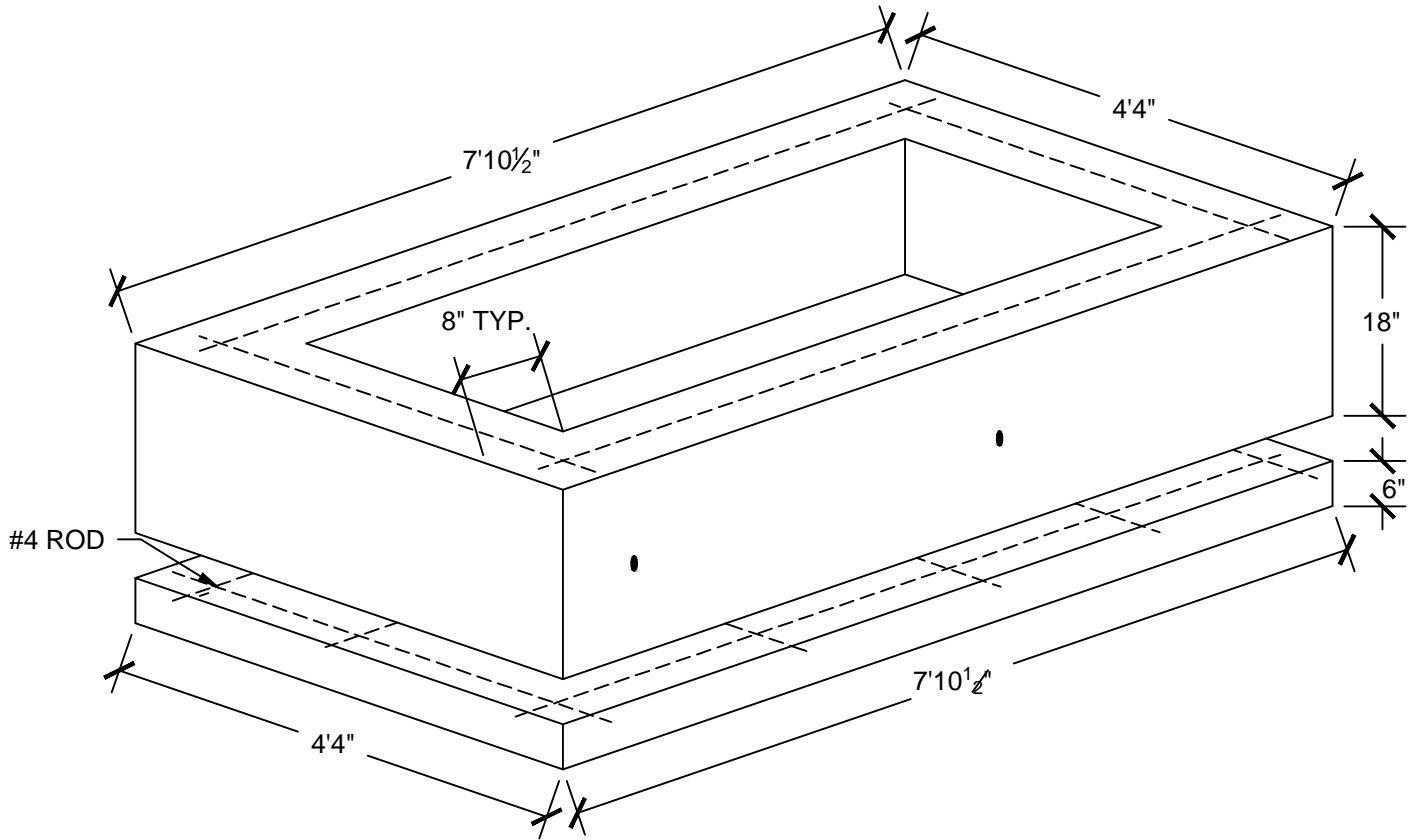
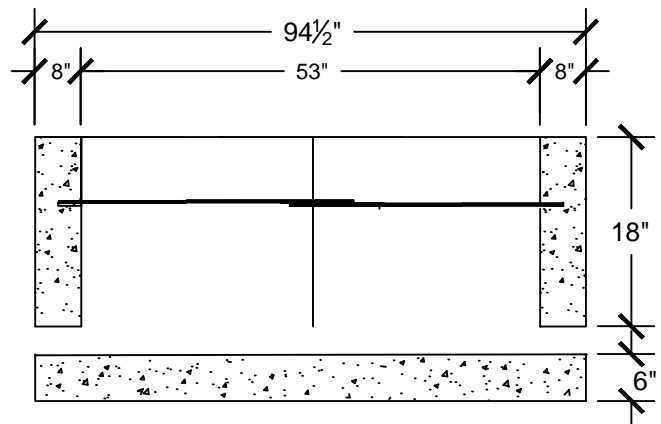

SECTION B-B

**CLASS "FSC" SELF-CONSOLIDATING CONCRETE  
 4,000 PSI**



PROJECT

---

TITLE

**TYPE II SUMP**

|             |     |          |                |
|-------------|-----|----------|----------------|
| DESIGN      | BGR | 01/23/14 | FILE No.       |
| CADD        | PJK | 06/02/14 | SCALE AS SHOWN |
| REVIEW      | MF  | 12/23/15 | REV. 0         |
| PROJECT No. |     |          |                |

**DRAWING: TYPE II SUMP**