

△	11/30/15	XXX	REV_DESC	LJH	MF	JML
REV	DATE	DES	REVISION DESCRIPTION	CADD	CHK	RW

RISERS

WEAKENED SECTION KNOCK OUTS

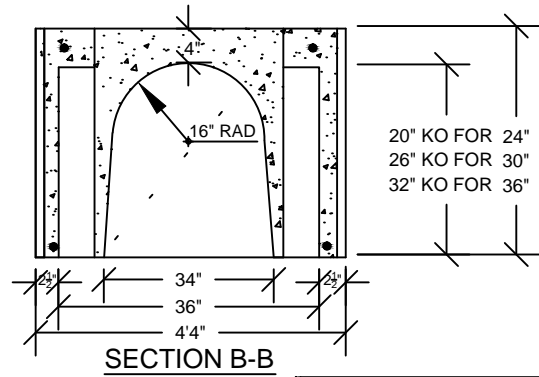
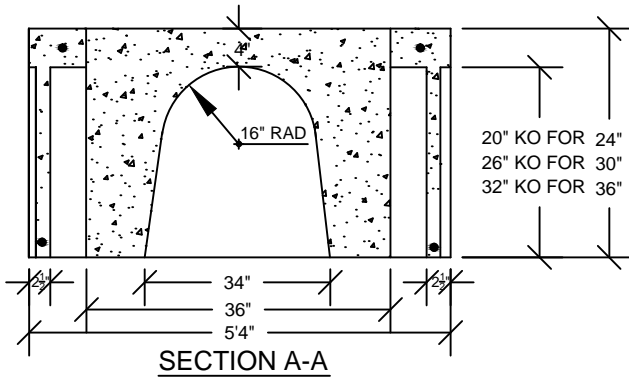
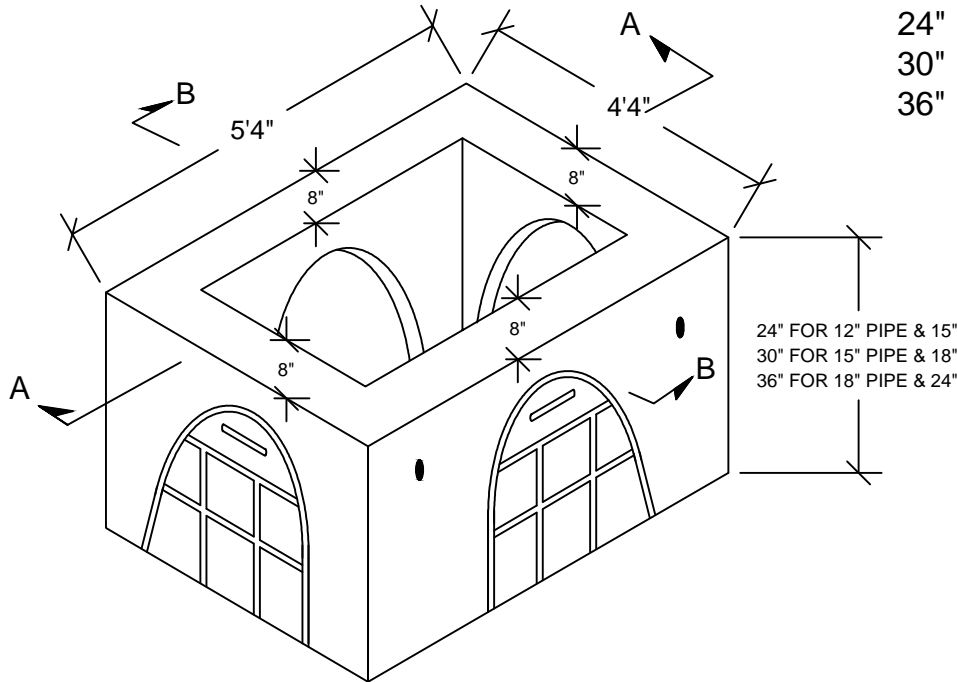

**CLASS "FSC" SELF-CONSOLIDATING CONCRETE
4,000 PSI**



PROJECT			
TITLE			
RISERS WKN KO			
DESIGN	BGR	01/23/14	FILE No.
CADD	LJH	01/23/14	SCALE AS SHOWN
REVIEW	MF	11/30/15	REV. 0
PROJECT No.			

DRAWING: RISERS WKN KO