

REV.2—REVISED DIMENSIONS PER NEW
FRAME AND LONGER CONVEYOR

24-078

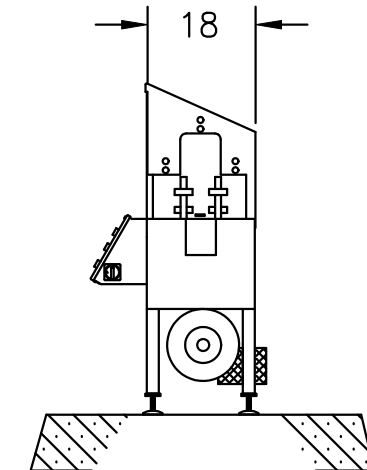
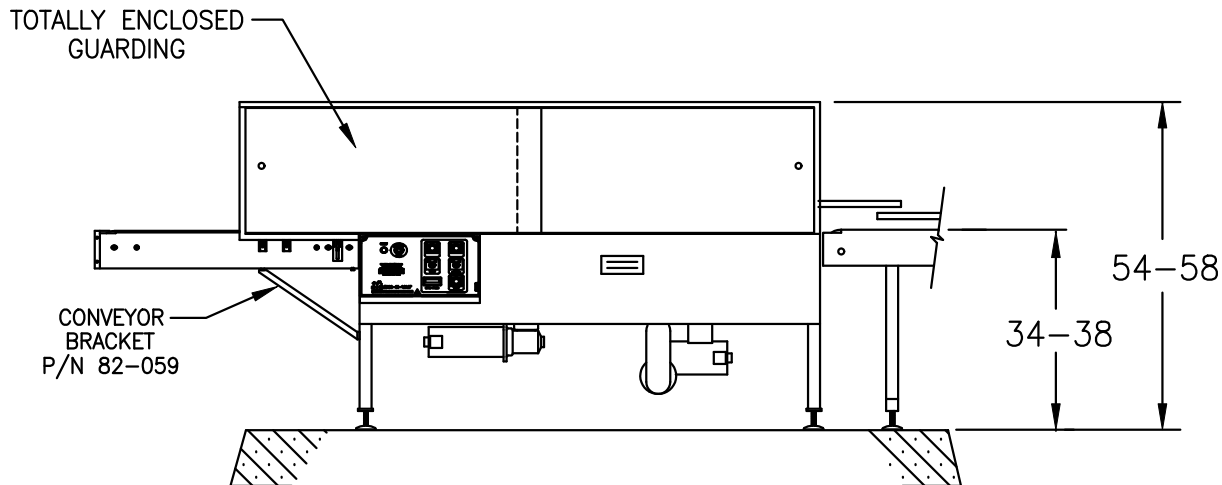
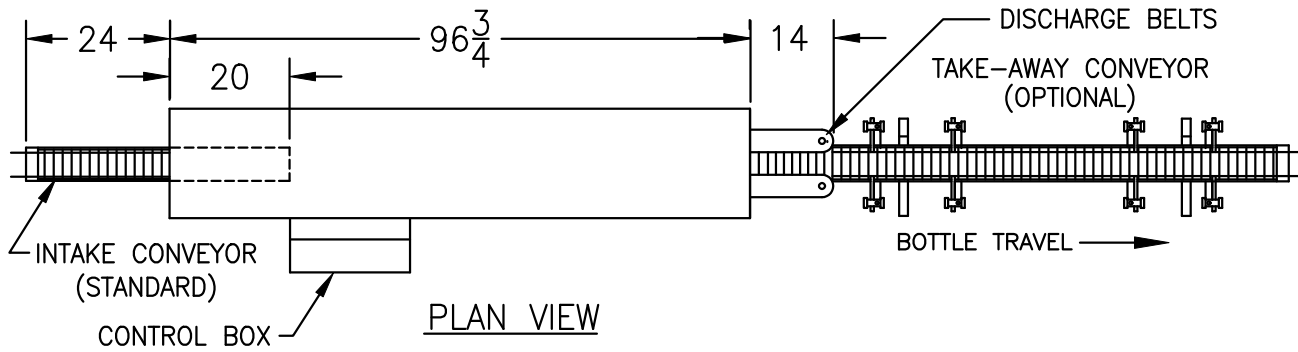

This document is the property of Kaps-All Packaging Systems, Inc. and contains proprietary and confidential information which must not be duplicated, used or disclosed other than as expressly authorized by Kaps-All Packaging Systems, Inc.

UNLESS NOTED OTHERWISE, ALL DIMENSIONS ARE IN INCHES

REVISIONS			KAPS-ALL PACKAGING SYSTEMS INC. RIVERHEAD, N.Y.		
NO.	DATE	BY			
1	4-25-95	J.M.	AUTOMATIC BOTTLE CLEANER - INVERTER		
2	10/31/2003	P.C.	MODEL AC-65		
3			DRAWN BY P.C.	SCALE NONE	MATERIAL N/A
4			CHK'D	DATE 7/20/93	DRAWING NO.
5			PLOT SIZE=.03125	APP'D	24-078