

This document is the property of Auto-Mate Technologies, LLC and contains proprietary and confidential information which must not be duplicated, used or disclosed other than as expressly authorized by Auto-Mate Technologies, LLC

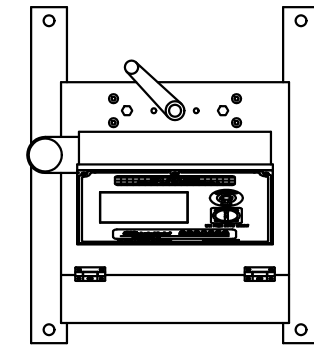
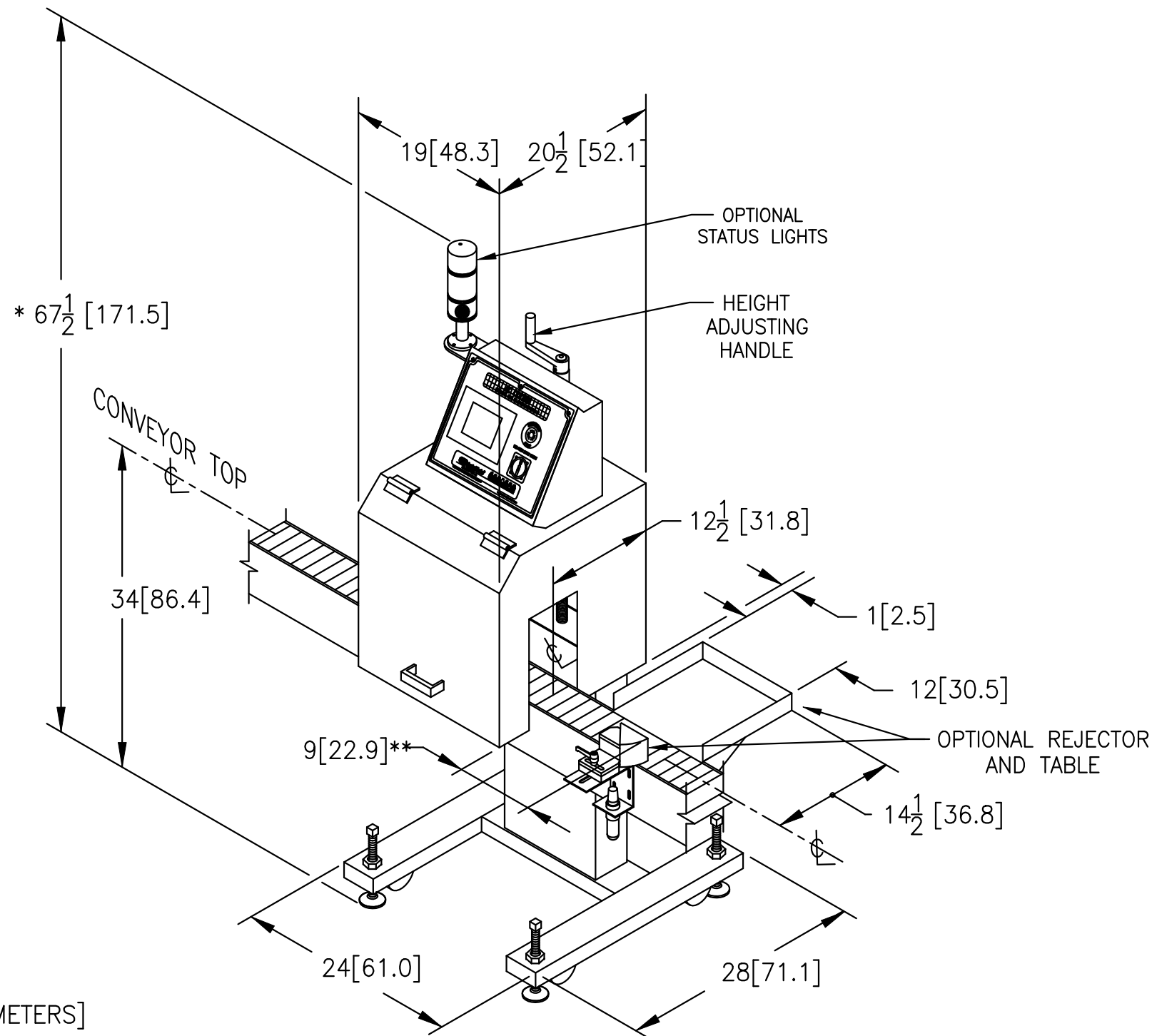

TOP VIEW

MODEL AM-DP

DIMENSIONS SHOWN ARE INCHES [CENTIMETERS]

\*THIS DIMENSION BASED ON A 34 [86.4] HIGH CONVEYOR AND A 6 [15.2] TALL CONTAINER. MACHINE CAN ACCOMODATE CONTAINERS

\*\* THE REJECTOR CAN BE MOUNTED FROM 9 [22.9] TO 44 [111.8] FROM THE MACHINE

1 [2.54] TO 14 [35.6] TALL STANDARD  
1 [2.54] TO 22 [55.9] TALL OPTIONAL.

DIMENSIONS AND SPECIFICATIONS ARE SUBJECT TO CHANGE.

SUPPLY = 110-125 VAC 2 AMPS, 50/60 HZ.

REVISIONS			AUTO-MATE TECHNOLOGIES, LLC RIVERHEAD, N.Y.				
NO.	DATE	BY					
1			DIAGNOSTIC MONITORING CENTER MODELS AM-QC AND AM-DA				
2							
3			DRAWN BY	PC	SCALE 1/16"=1"	SHEET 1 OF 1	
4			0.0625	P	SIZE	REV.	DRAWING NO.
5			DATE 10/20/2010		B	0	107-034